

I/A Series[®] Pressure Transmitters

**IAP20 Absolute Pressure and IGP20 Gauge Pressure
with 4 to 20 mA Output Signal**

Installation, Operation, Calibration, Configuration, and Maintenance

Contents

| | |
|---|-----------|
| Figures..... | v |
| Tables..... | vi |
| 1. Introduction | 1 |
| General Description | 1 |
| Reference Documents | 1 |
| Transmitter Identification | 2 |
| Standard Specifications | 3 |
| Product Safety Specifications | 8 |
| 2. Installation | 11 |
| Transmitter Mounting | 11 |
| Typical Transmitter Piping | 12 |
| Positioning the Housing | 14 |
| Positioning the Display | 15 |
| Cover Locks | 16 |
| Wiring | 16 |
| 3. Operation Via Local Display | 21 |
| Testing the Display | 22 |
| Error Messages | 24 |
| 4. Calibration | 25 |
| General Calibration Notes | 25 |
| Calibration Setup | 27 |
| Calibration Using the Local Display | 30 |
| Zero Adjustment Using External Zero Button | 33 |
| Error Messages | 33 |
| 5. Configuration | 35 |
| Commentary on Configuration Structure Diagram | 37 |
| Reranging the Transmitter | 38 |
| Character Lists | 38 |
| Error Messages | 38 |

| | |
|---|-----------|
| 6. Maintenance | 41 |
| Parts Replacement | 41 |
| Rotating Process Covers for Venting | 45 |
| Index | 47 |

Figures

| | | |
|----|---|----|
| 1 | Transmitter Identification | 2 |
| 2 | Minimum Allowable Absolute Pressure vs. Process Temperature with Fluorinert Fill Fluid | 6 |
| 3 | Pipe Mounting | 11 |
| 4 | Surface Mounting | 12 |
| 5 | Typical Transmitter Piping | 13 |
| 6 | Hot Process Piping | 14 |
| 7 | Housing Screw or Clip Location | 15 |
| 8 | Positioning Display | 16 |
| 9 | Cover Lock Location | 16 |
| 10 | Accessing Field Terminals | 17 |
| 11 | Identification of Field Terminals | 17 |
| 12 | Supply Voltage and Loop Load | 18 |
| 13 | Loop Wiring | 20 |
| 14 | Wiring Several Transmitters to a Common Power Supply | 20 |
| 15 | Local Display Module | 21 |
| 16 | Top Level Structure Diagram | 22 |
| 17 | Display Test Segment Patterns | 23 |
| 18 | 4 to 20 mA Output Calibration Setup of Electronic Equipment | 28 |
| 19 | IAP20 and IGP20 Field Calibration Setup | 29 |
| 20 | Bench Calibration Setup | 30 |
| 21 | Calibration Structure Diagram | 32 |
| 22 | Configuration Structure Diagram | 36 |
| 23 | Replacing the Sensor Assembly | 44 |
| 24 | Replacing the Sensor Assembly (pvdf Inserts) | 44 |
| 25 | Sensor Cavity Venting and Draining | 45 |

Tables

| | | |
|---|--|----|
| 1 | Reference Documents | 1 |
| 2 | Electrical Safety Specifications | 9 |
| 3 | Error Messages | 24 |
| 4 | Calibration Menu | 31 |
| 5 | Error Messages | 33 |
| 6 | Configuration Menu | 35 |
| 7 | Alphanumeric Character List | 38 |
| 8 | Numeric Character List | 38 |
| 9 | Error Messages | 38 |

1. Introduction

General Description

The IAP20-A Absolute Pressure Transmitters and the IGP20-A Gauge Pressure Transmitters measure pressure by applying the pressure to a silicon strain gauge microsensor. This microsensor converts the pressure to a change in resistance, and the resistance change is converted to a 4 to 20 mA signal proportional to the pressure. This measurement signal is transmitted to remote receivers over the same two wires that supply power to the transmitter.

For more detailed information on the principle of operation of the transmitter, refer to TI 037-096, available from Invensys.

Reference Documents

Table 1. Reference Documents

| Document | Description |
|-----------------------|--|
| Dimensional Prints | |
| DP 020-342 | Dimensional Print – PSFLT Pressure Seals |
| DP 020-343 | Dimensional Print – PSFPS and PSFES Pressure Seals |
| DP 020-345 | Dimensional Print – PSFAR Pressure Seals |
| DP 020-347 | Dimensional Print – PSTAR Pressure Seals |
| DP 020-349 | Dimensional Print – PSISR Pressure Seals |
| DP 020-351 | Dimensional Print – PSSCR Pressure Seals |
| DP 020-353 | Dimensional Print – PSSCT Pressure Seals |
| DP 020-354 | Dimensional Print – PSSSR Pressure Seals |
| DP 020-355 | Dimensional Print – PSSST Pressure Seals |
| DP 020-447 | Dimensional Print – IAP10 and IAP20 Absolute Pressure and IGP10, IGP20, IGP25, and IGP50 Gauge Pressure Transmitters |
| Parts Lists | |
| PL 009-007 | Parts List – IAP20 Absolute and IGP20 Gauge Pressure Transmitters |
| Instructions | |
| MI 020-369 | Instruction – Pressure Seals |
| MI 022-138 | Instruction – Bypass Manifolds - Installation and Maintenance |
| Technical Information | |
| TI 37-75b | Technical Information – Transmitter Material Selection Guide |
| TI 037-097 | Technical Information – Process Sealing of I/A Series Pressure Transmitters for use in Class 1, Zone 0, 1, and 2 Hazardous Locations |

Transmitter Identification

See Figure 1 for transmitter data plate contents. For a complete explanation of the Model Number code, see the parts list. The firmware version is shown on the top line of the display when the transmitter is powered.

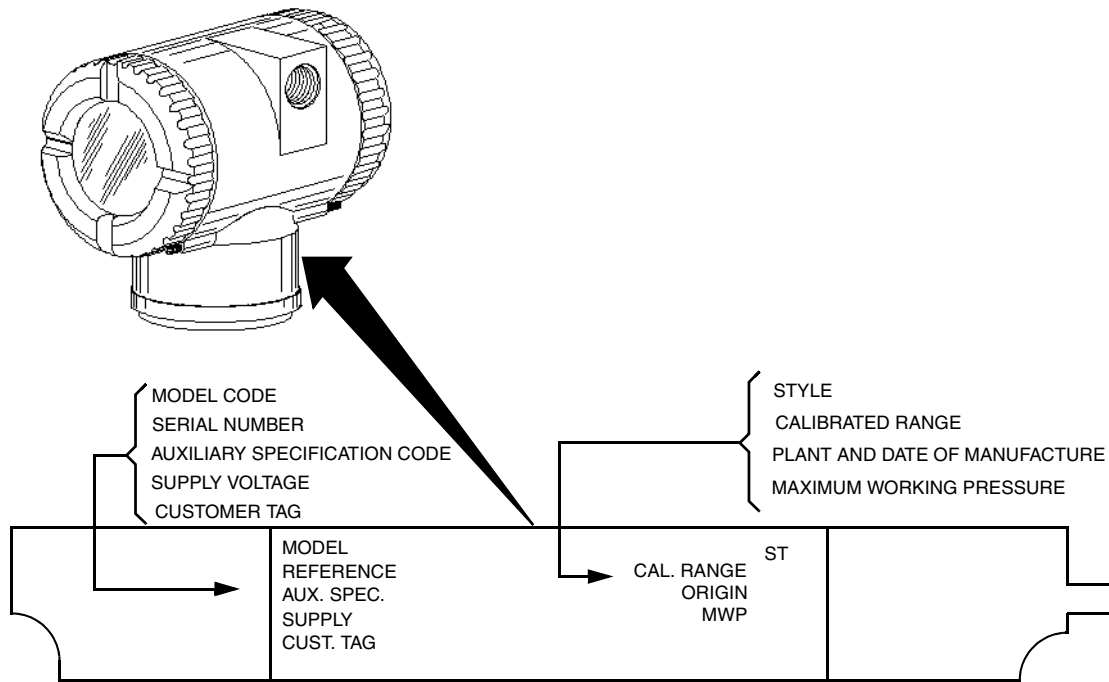

Figure 1. Transmitter Identification

Standard Specifications

Operative Limits

| Influence | Operative Limits |
|--|---|
| Sensor Body Temperature ^(a) | |
| Silicone Fill Fluid | -46 and +121°C (-50 and +250°F) |
| Fluorinert Fill Fluid | -29 and +121°C (-20 and +250°F) |
| pvc Inserts | -7 and +82°C (20 and 180°F) |
| Electronics Temperature | -40 and +85°C (-40 and +185°F) |
| With LCD Display | -40 and +85°C (-40 and +185°F) ^(b) |
| Relative Humidity | 0 and 100% |
| Supply Voltage ^(c) | 11.5 and 42 V dc |
| Output Load | 0 and 1450 ohms |
| Mounting Position | No Limit |
| Vibration | 6.3 mm (0.25 in) double amplitude from 5 to 15 Hz with aluminum housing and from 5 to 9 Hz with 316 ss housing. 0 to 30 m/s (0 to 3 “g”) from 15 to 500 Hz with aluminum housing and 0 to 10 m/s (0 to 1 “g”) from 9 to 500 Hz with 316 ss housing. |

(a) Refer to MI 020-369 for temperature limits with pressure seals.

(b) Display updates are slowed and readability decreased below temperatures of -20°C (-4°F).

(c) 11 V dc with optional shorting block (AS code SB-11)

Span and Range Limits

| Span Limit Code | Span Limits ^(a) | Range Limits ^(a) |
|--------------------|---|--|
| A ^(b,c) | 0.12 and 7.5 kPa 0.5 and 30 inH ₂ O | -7.5 and +7.5 kPa -30 and +30 inH ₂ O |
| B | 0.87 and 50 kPa 3.5 and 200 inH ₂ O | -50 and +50 kPa -200 and +200 inH ₂ O |
| C | 0.007 and 0.21 MPa 28 and 840 inH ₂ O | -0.1 and +0.21 MPa -410 and +840 inH ₂ O |
| D | 0.07 and 2.1 MPa 10 and 300 psi | -0.1 and +2.1 MPa -14.7 and +300 psi |
| E | 0.7 and 21 MPa 100 and 3000 psi | -0.1 and +21 MPa -14.7 and +3000 psi |
| F ^(b) | 1.38 and 34.5 MPa 200 and 5000 psi | -0.1 and 34.5 MPa -14.7 and 5000 psi |

(a) Values listed are in absolute or gauge pressure units, as applicable.

(b) Applicable to IGP20 only.

(c) Not available with pressure seals.

Maximum Overrange Pressure and Proof Pressure

! CAUTION

1. Exceeding the overrange pressure limit for the transmitter can cause damage to the transmitter, degrading its performance.
 2. The transmitter may be nonfunctional after application of the proof pressure.
-

| Span Limit Code | Maximum Overage Pressure ^(a) | Proof Pressure ^(a,b) |
|-----------------|---|---------------------------------|
| A | 25 MPa (3625 psi) | 100 MPa (14500 psi) |
| B | 25 MPa (3625 psi) | 100 MPa (14500 psi) |
| C | 25 MPa (3625 psi) | 100 MPa (14500 psi) |
| D | 25 MPa (3625 psi) | 100 MPa (14500 psi) |
| E | 31 MPa (4500 psi) | 100 MPa (14500 psi) |
| F | 52 MPa (7500 psi) | 100 MPa (14500 psi) |

(a) Values listed are in absolute or gauge pressure units, as applicable

(b) Meets ANSI/ISA Standard S82.03-1988.

The maximum overrange pressure and proof pressure may be different depending on the bolting material. Refer to the table below.

| Transmitter Configuration (Bolting Material) ^(c) | Maximum Static and Overage Pressure Rating ^(a,e) | | Proof Pressure Rating ^(b) | |
|--|--|------|--------------------------------------|-------|
| | MPa | Psi | MPa | Psi |
| Option “-B2” (17-4 PH ss), Option “-D3” or “-D7” | 25 | 3625 | 100 | 14500 |
| Option “B1” (316 ss) or Option “-D5” | 15 | 2175 | 60 | 8700 |
| Option “B3” (B7M) | 20 | 2900 | 70 | 11150 |
| Option “-D1” | 16 | 2320 | 64 | 9280 |
| Option “-D2”, “-D4”, “-D6”, or “-D8” ^(d) | 10 | 1500 | 40 | 6000 |
| Option “D9” (17-4 PH ss) | 40 | 5800 | 100 | 14500 |

| Transmitter Configuration (Bolting Material) ^(c) | Maximum Static and Overrange Pressure Rating ^(a,c) | | Proof Pressure Rating ^(b) | |
|--|--|-----|--------------------------------------|-----|
| | MPa | Psi | MPa | Psi |

(a) Either side can be at higher pressure during overrange.

(b) Meets ANSI/ISA Standard S82.03-1988.

(c) -D1 = DIN Single ended process cover with M10 B7 bolting.

-D2 = DIN Double ended process cover with M10 B7 bolting

-D3 = DIN Single ended process cover with 7/16 in B7 bolting.

-D4 = DIN Double ended process cover with 7/16 in B7 bolting.

-D5 = DIN Single ended process cover with 7/16 in 316 ss bolting.

-D6 = DIN Double ended process cover with 7/16 in 316 ss bolting.

-D7 = DIN Single ended process cover with 7/16 in 17-4 ss bolting.

-D8 = DIN Double ended process cover with 7/16 in 17-4 ss bolting.

-D9 = DIN Single ended process cover with 7/16 in 17-4 ss bolting.

(d) Limited to operating temperatures ranging from 0 to 60°C (32 to 140°F).

(e) When Structure Codes 78/79 are used (pvdf insert in the Hi side process cover), the maximum overrange is 2.1 MPa (300 psi) and temperature limits are -7 and +82°C (20 and 180°F).

Elevated Zero and Suppressed Zero

For applications requiring an elevated or suppressed zero, the maximum span and the upper and lower range limits of the transmitter can not be exceeded.

Sensor Fill Fluid

Silicone Oil (DC 200) or Fluorinert (FC-43)

Neobee M-20 (for transmitters with sanitary process connection)

Minimum Allowable Absolute Pressure vs. Process Temperature

With Silicone Fill Fluid: up to 120 °C (250 °F) at full vacuum.

With Fluorinert Fill Fluid: Refer to Figure 2.

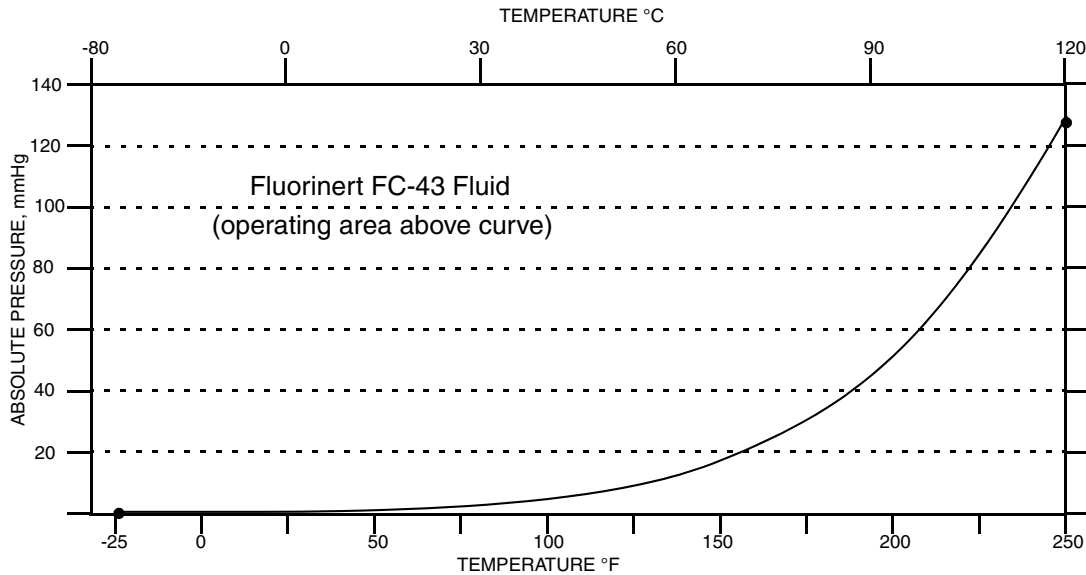

Figure 2. Minimum Allowable Absolute Pressure vs. Process Temperature with Fluorinert Fill Fluid

Mounting Position

The transmitter can be mounted in any orientation. It can be directly mounted to the process with either the direct connected or pipe mounted designs. The housing can be rotated up to one full turn to any desired position for access to adjustments, display, or conduit connections. See “Positioning the Housing” on page 14. The display (if present) can also be rotated in the housing to any of four different positions at 90° increments. See “Positioning the Display” on page 15.

NOTE

Position effect zero shift for all calibrated spans can be eliminated by readjusting zero output after installation.

Approximate Mass

| | |
|---------------------------------------|-----------------------|
| IAP20, IGP20 (w/o process connector): | 3.5 kg (7.8 lb) |
| IAP20 (with process connector): | 3.8 kg (8.5 lb) |
| IGP20 (with process connector): | 4.2 kg (9.2 lb) |
| With Optional 316 ss Housing: | Add 1.1 kg (2.4 lb) |
| With Pressure Seals: | Varies with seal used |

Process Connections

IAP20 and IGP20 transmitters are connected to the process via a 1/4 NPT thread or any one of a number of optional process connectors.

Process Wetted Materials

| | |
|------------|---|
| Diaphragm: | Co-Ni-Cr, 316L ss, Hastelloy C, gold-plated 316L ss, Monel, or tantalum |
|------------|---|

| | |
|------------------------------------|--|
| Covers and Process Connectors: | 316 ss, carbon steel, Hastelloy C, or Monel, or pvdf inserts |
| Pressure Seals: | Refer to MI 020-369 |
| Sanitary Process Connections: | 316L ss, Hastelloy C |
| Pulp and Paper Process Connections | 316L ss, Hastelloy C |

Process Pressure and Temperature Limits for Pressure Seals

Refer to MI 020-369

Electrical Connections

Field wires enter through 1/2 NPT, PG 13.5, or M20 threaded entrances on either side of the electronics housing. Leads terminate under screw terminals and washers on the terminal block in the field terminal compartment. To maintain RFI/EMI, environmental, and explosionproof ratings, unused conduit connection must be plugged with metal plug (provided), inserted to five full turns.

Field Wiring Reversal

Accidental reversal of field wiring will not damage the transmitter, provided the current is limited to 1 A or less by active current limiting or loop resistance. Sustained currents of 1 A will not damage the electronics module or sensor but could damage the terminal block assembly and external instruments in the loop.

Adjustable Damping

The transmitter response time is normally 1.0 second or the electronically adjustable setting of 0.00 (none), 2, 4, or 8, seconds, whichever is greater, for a 90% recovery from an 80% input step as defined in ANSI/ISA S51.1.

Output Signal

4 to 20 mA dc linear.

Zero and Span Adjustments

Adjustable at the transmitter using the local display. An optional external self-contained moisture sealed pushbutton assembly allows local resetting of zero without removing housing cover (except on model IDP10-AS).

Powerup Time

Less than 2.0 seconds for output to reach the first valid measurement, then at the electronic damping rate to reach the final measured variable value.

Supply Current

Power supply must be capable of providing 22 mA current. Ripple of up to 2 V pp (50/60/100/120 Hz) is tolerable, but instantaneous voltage must remain within specified range.

Electrical Ground Connections

The transmitter is equipped with an internal ground connection within the field wiring compartment and an external ground connection at the base of the electronics housing. To minimize galvanic corrosion, place the wire lead or terminal between the captive washer and loose washer on the external ground screw. If shielded cable is used, earth (ground) the shield at the field enclosure **only**. Do **not** ground the shield at the transmitter.

Test Points

The banana plug receptacles (designated **CAL**) can be used to check transmitter output. Measurements should be 100 to 500 mV dc for 0 to 100% transmitter output.

HHT Terminals

As the top terminal is blocked, this transmitter does not communicate with the PC20, PC50 HART Communicator, or IFDC.

Product Safety Specifications

— **DANGER** —

To prevent possible explosions and to maintain flameproof, explosionproof, and dust-ignitionproof protection, observe applicable wiring practices. Plug unused conduit opening with the provided metal pipe plug. Both plug and conduit must engage a minimum of five full threads for 1/2 NPT connections; seven full threads for M20 and PG 13.5 connections.

— **WARNING** —

To maintain IEC IP66 and NEMA Type 4X protection, the unused conduit opening must be plugged with the metal plug provided. Use a suitable thread sealant on both conduit connections. In addition, the threaded housing covers must be installed. Turn covers to seat the O-ring into the housing and then continue to hand tighten until the cover contacts the housing metal-to-metal.

— **NOTE** —

1. These transmitters have been designed to meet the electrical safety description listed in Table 2. For detailed information or status of testing laboratory approvals/certifications, contact Invensys.
 2. Wiring restrictions required to maintain electrical certification of the transmitter are provided in these instructions. See “Wiring” on page 16
-

Table 2. Electrical Safety Specifications

| Agency Certification, Types of Protection, and Area Classification | Application Conditions | Electrical Safety Design Code |
|---|--|-------------------------------|
| ATEX flameproof: II 2 GD EEx d IIC, Zone 1. | KEMA 00ATEX2019X Temperature Class T6, T85°C, Ta = -40 to +80°C | D |
| CSA explosionproof for Class I, Division 1, Groups B, C, and D; dust-ignitionproof for Class II, Division 1, Groups E, F, and G; Class III, Division 1. | Maximum Ambient Temperature 85°C (185°F). | C |
| CSA for Class I, Division 2, Groups A, B, C, and D; Class II, Division 2, Groups F and G; Class III, Division 2. | Temperature Class T6 at 40°C (104°F) and T4A at 85°C (185°F) maximum ambient. | |
| CSA field device zone certified flameproof Ex d IIC. Also, All certifications of Code C above. | Maximum Ambient Temperature 85°C (185°F). | B |
| FM explosionproof for Class I, Division 1, Groups B, C, and D; dust-ignitionproof for Class II, Division 1, Groups E, F, and G; Class III, Division 1. | Temperature Class T6 at 80°C (176°F) and T5 at 85°C (185°F) maximum ambient. | F |
| FM nonincendive for Class I, Division 2, Groups A, B, C, and D; Class II, Division 2, Groups F and G; Class III, Division 2. | Temperature Class T4A at 40°C (104°F) and T4 at 85°C (185°F) maximum ambient. | |
| FM field device zone certified flameproof AEx d IIC. Also, all certifications of Code F above. | Temperature Class T6 at 80°C (176°F) and T5 at 85°C (185°F) maximum ambient. | G |
| IECEX flameproof: Ex d IIC | IECEX FMG 06.0007X, Ex d IIC T6 Ta=80°C, T5 Ta=85°C Ambient Temperature -20 to +85°C | V |

ATEX and IECEX Warnings

Do not open while circuits are alive.

ATEX Compliance Documents

EN 50014: 1997

EN 50018: 1994

IECEX Compliance Documents

IEC 60079-0 (Edition 4.0): 2004

IEC 60079-1 (Edition 5): 2003

2. Installation

— **! CAUTION** —

To avoid damage to the transmitter sensor, do not use any impact devices, such as an impact wrench or stamping device, on the transmitter.

— **NOTE** —

1. The transmitter should be mounted so that any moisture condensing or draining into the field wiring compartment can exit through one of the two threaded conduit connections.
 2. Use a suitable thread sealant on all connections.
-

Transmitter Mounting

The IAP20 and IGP20 transmitters must be mounted to a vertical or horizontal pipe or a surface using the mounting set. See Figures 3 and 4. For dimensional information, refer to DP 020-447.

— **NOTE** —

1. If the transmitter is not installed in the vertical position, readjust the zero output to eliminate the position zero effect. Be aware that an absolute pressure transmitter cannot be zeroed by venting the transmitter to atmosphere.
 2. The lower conduit port can be used as a drain for moisture buildup in terminal compartment.
-

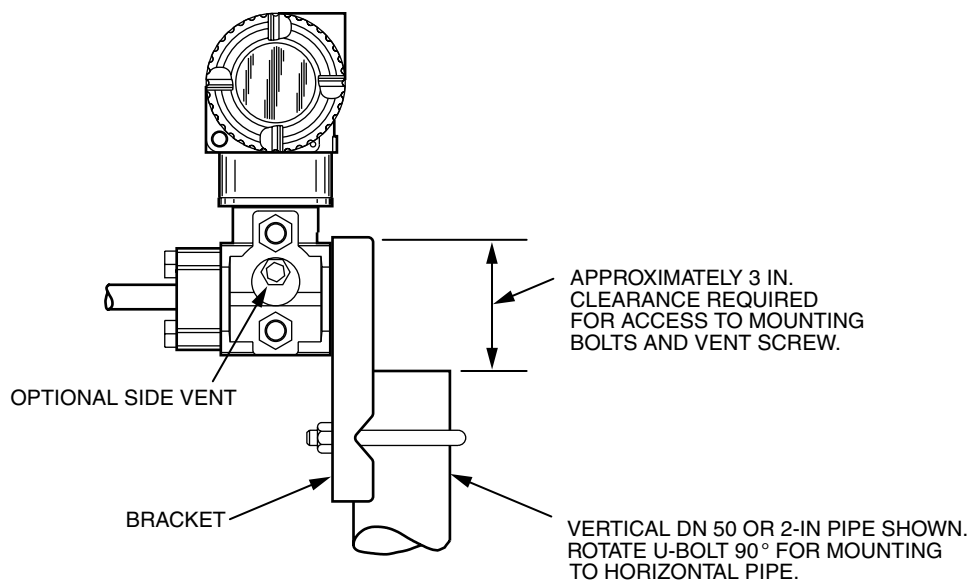

Figure 3. Pipe Mounting

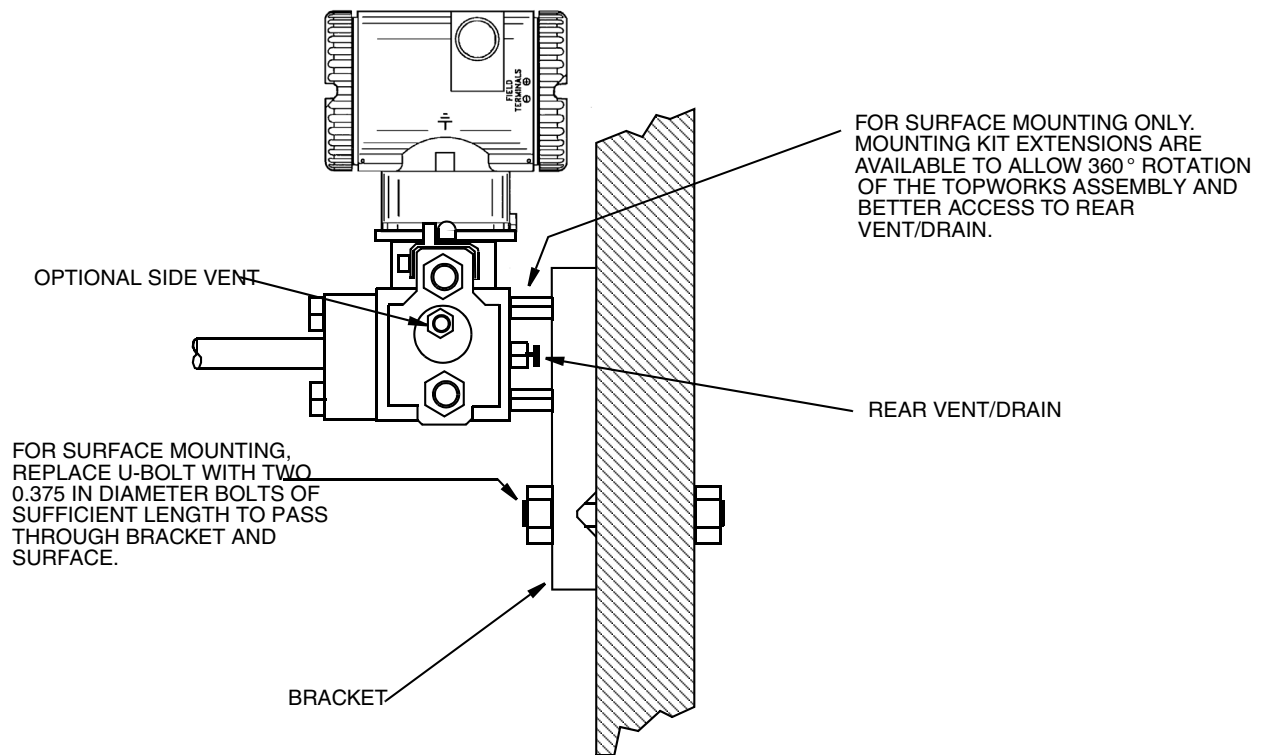

Figure 4. Surface Mounting

Typical Transmitter Piping

Figure 5 shows a typical piping application. Tighten the process connector bolts to a torque of 61 N·m (45 lb·ft) and drain plugs and vent screws to a torque of 20 N·m (15 lb·ft).

NOTE

1. Invensys recommends the use of snubbers in installations prone to high levels of fluid pulsations.
 2. When structure codes 78/79 (pvdf insert) are used on an IAP20, the process connection must be made directly to the pvdf insert in the high side process cover.
-

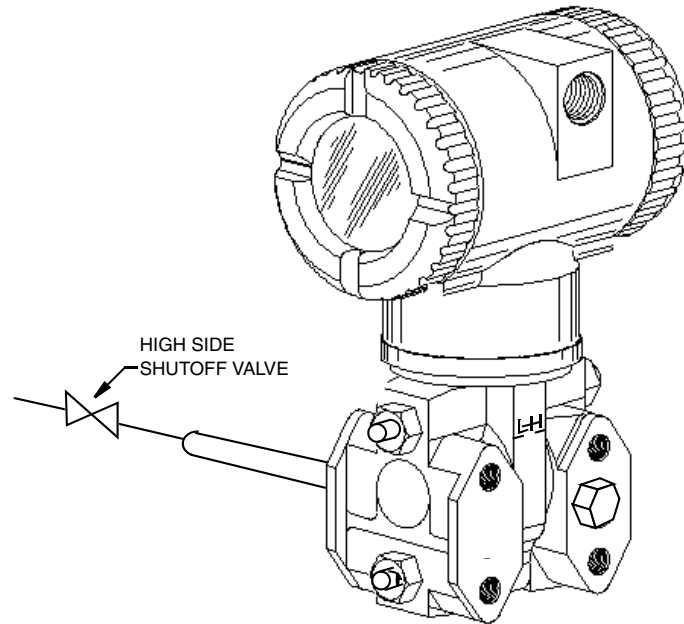

Figure 5. Typical Transmitter Piping

For hot process applications above the operative limits of your transmitter [121°C (250°F) for silicone fill fluid or 82°C (180°F) for fluorinert fill fluid], such as steam, additional piping is required to protect the transmitter from the hot process. See Figure 6. The piping is filled with water or process fluid. Mount the transmitter below the pressure connection at the pipe. Although the transmitter is shown mounted vertically, you can also mount it horizontally. The calibration tee is not required if a calibration screw is used for field calibrations.

If trapped vapor pockets cannot be tolerated in a liquid service and a horizontal process connection is used, install a pipe elbow and vertically position the transmitter with the housing **below** the process connection.

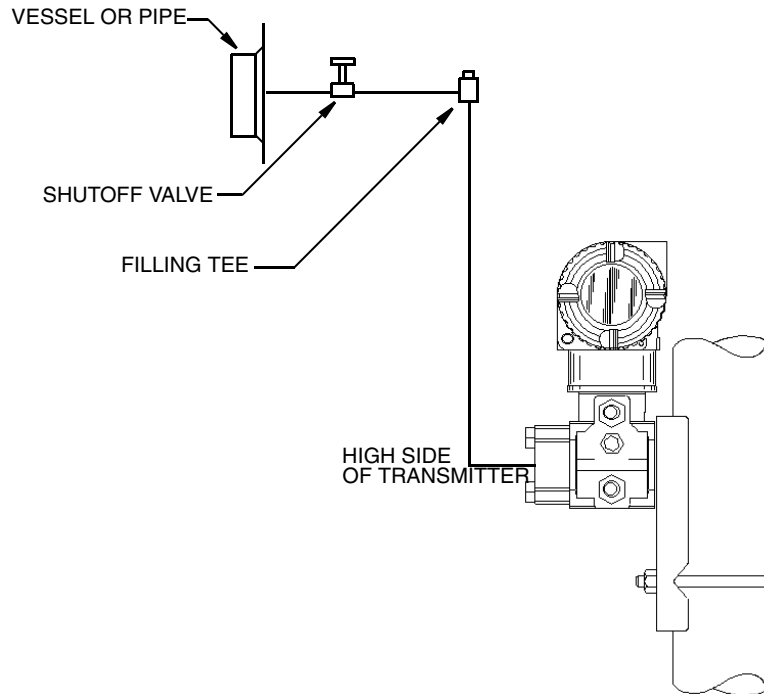

Figure 6. Hot Process Piping

Positioning the Housing

The transmitter housing (topworks) can be rotated up to one full turn in the counterclockwise direction when viewed from above for optimum access to adjustments, display, or conduit connections. Housings have either an anti-rotation screw or a retention clip that prevent the housing from being rotated beyond a safe depth of housing/sensor thread engagement.

! WARNING

If the electronics housing is removed for maintenance, it must be hand tightened to the bottom of the threads, but not over-tightened upon reassembly. See “Removing and Reinstalling the Housing Assembly” on page 42.

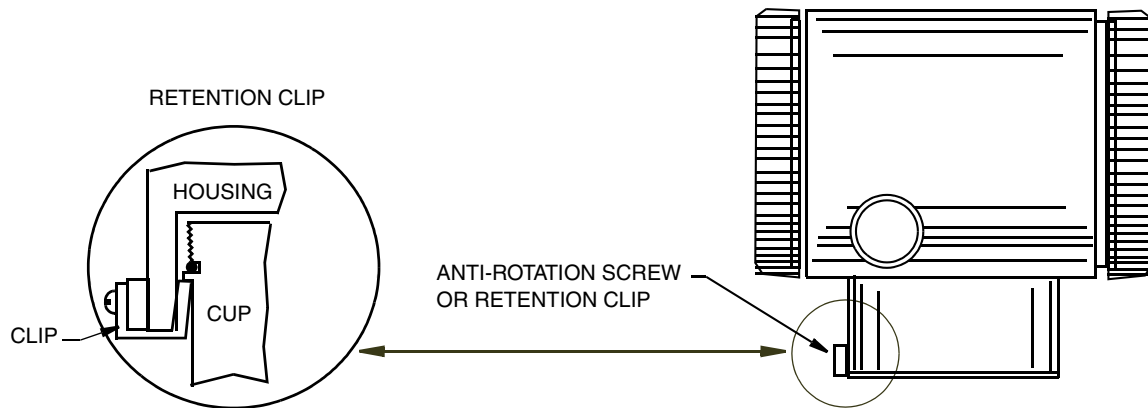

Figure 7. Housing Screw or Clip Location

Positioning the Display

The display can be rotated within the housing to any of four positions at 90° increments. To do this, refer to Figure 8 and perform the following:

1. Turn off power source to the transmitter.
2. Screw in the cover lock (if present) and remove the electronics compartment cover by rotating it counterclockwise.
3. Remove the electronics module by unscrewing the two screws closest to the sides of the transmitter and pulling out the module.
4. If turning the display 180°, turn and return the module to the housing by reversing Step 3.
5. If turning the display 90° in either direction:
 - a. Remove the two (2) plastic buttons (plugs) by pushing them out from the backside of the module.

— NOTE —

Plastic buttons were not provided on some early versions of the electronics module.

- b. Unscrew the two (2) screws from the module and then rethread them back into the module at 90° from their original position.
 - c. Insert the two (2) plastic buttons into the two open screw holes in the module. (To order plastic buttons for earlier versions of the electronics modules or for replacement, see PL 009-007.
 - d. Return the module to the housing by reversing Step 3.
6. Reinstall the cover onto the housing by rotating it clockwise until the O-ring contacts the housing; then continue to hand tighten as much as possible (at least 1/4 turn). If cover locks are present, align the serration in the cover with the lock and unscrew it until it extends into the cover serration to prevent unwanted cover rotation.

- Restore power to transmitter.

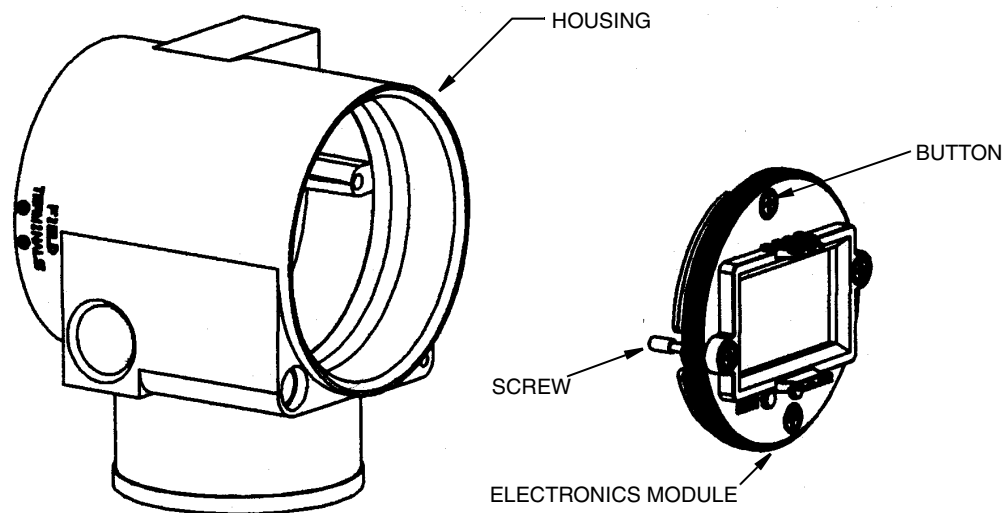

Figure 8. Positioning Display

Cover Locks

Electronic housing cover locks, shown in Figure 9, are provided as standard with certain agency certifications and as part of the Custody Transfer Lock and Seal option. To lock the covers, unscrew the locking pin until approximately 6 mm (0.25 in) shows, lining up the hole in the pin with the hole in the housing. Insert the seal wire through the two holes, slide the seal onto the wire ends and crimp the seal.

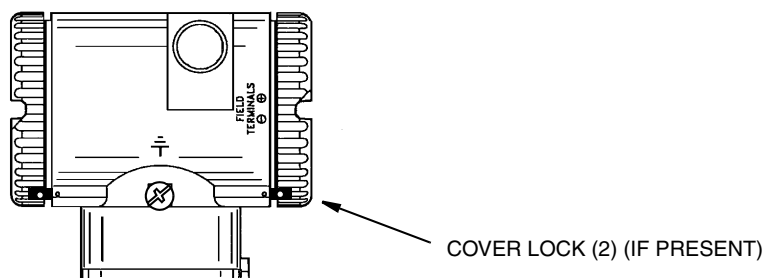

Figure 9. Cover Lock Location

Wiring

The installation and wiring of your transmitter must conform to local code requirements.

— **WARNING** —

ATEX requires that when the equipment is intended to be used in an explosive atmosphere caused by the presence of combustible dust, cable entry devices and

blanking elements shall provide a degree of ingress protection of at least IP6X. They shall be suitable for the conditions of use and correctly installed.

— **NOTE**

Invensys recommends the use of transient/surge protection in installations prone to high levels of electrical transients and surges.

Accessing Transmitter Field Terminals

For access to the field terminals, thread the cover lock (if present) into the housing to clear the threaded cover and remove the cover from the field terminals compartment as shown in Figure 10. Note that the embossed letters **FIELD TERMINALS** identify the proper compartment.

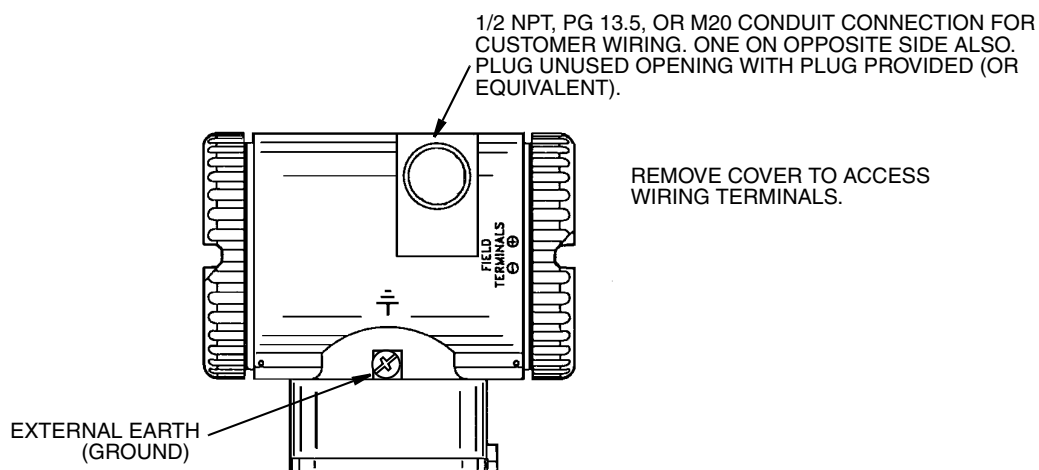

Figure 10. Accessing Field Terminals

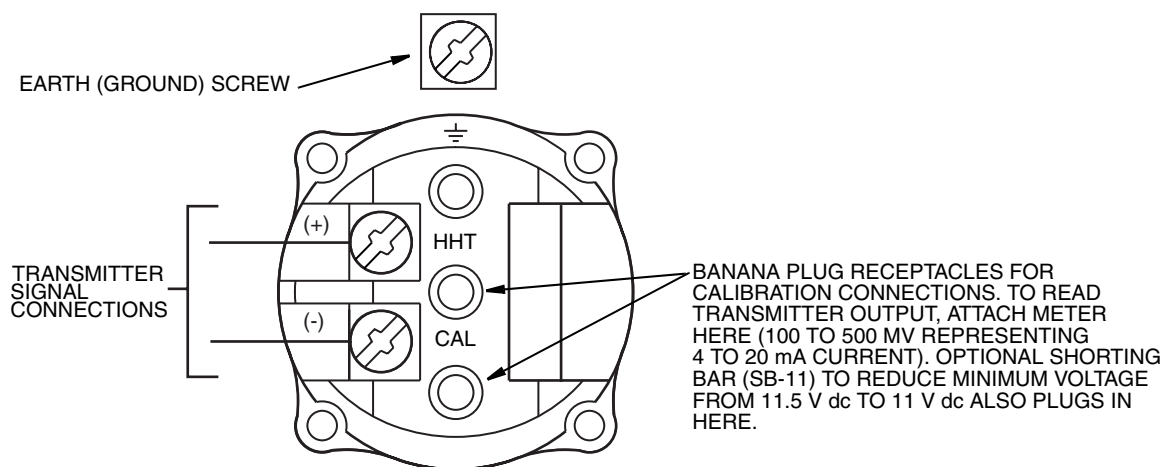

Figure 11. Identification of Field Terminals

Wiring the Transmitter to a Control Loop

When wiring a transmitter with 4 to 20 mA output signal, the supply voltage and loop load must be within specified limits. The supply output load vs. voltage relationship is:

$$R_{MAX} = 47.5 (V - 11.5) \text{ and is shown in Figure 12.}$$

NOTE

The relationship when the optional shorting bar is used is:

$$R_{MAX} = 46.8 (V - 11).$$

Any combination of supply voltage and loop load resistance in the shaded area can be used. To determine the loop load resistance (transmitter output load), add the series resistance of each component in the loop, excluding the transmitter. The power supply must be capable of supplying 22 mA of loop current.

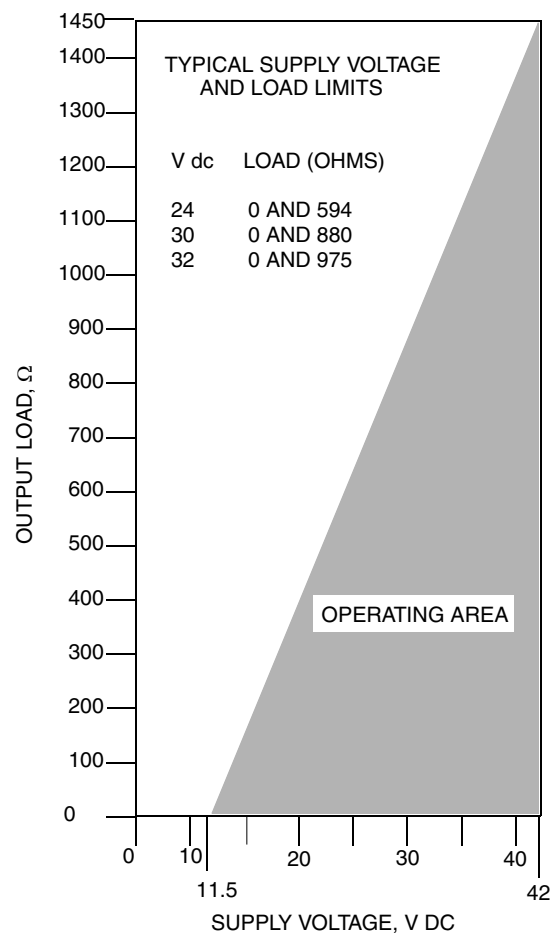

Figure 12. Supply Voltage and Loop Load

Examples:

1. For a loop load resistance of 880 Ω, the supply voltage can be any value from 30 to 42 V dc.
2. For a supply voltage of 24 V dc, the loop load resistance can be any value from zero to 594 Ω.

To wire one or more transmitters to a power supply, proceed with the following steps.

1. Screw in cover lock (if present) and remove the field terminals compartment cover by rotating it counterclockwise.
2. Run signal wires (0.50 mm² or 20 AWG, typical) through one of the transmitter conduit connections. Use twisted single pair to protect the 4 to 20 mA output from electrical noise. Screened (shielded) cable may be required in some locations.

— **NOTE** —

Do not run transmitter wires in same conduit as mains (ac power) wires.

3. If shielded cable is used, earth (ground) the shield at the power supply **only**. Do not ground the shield at the transmitter. Cut and/or tape the shield so it cannot contact the metal housing.
4. Plug unused conduit connection with the 1/2 NPT, PG 13.5, or M20 metal plug provided (or equivalent). To maintain specified explosionproof and dust-ignitionproof protection, plug must engage a **minimum** of five full threads. Thread sealant is recommended.
5. Connect an earth (ground) wire to the earth terminal in accordance with local practice.

— **! CAUTION** —

If the signal circuit must be earthed (grounded), it is preferable to do so at the negative terminal of the dc power supply. To avoid errors resulting from earth loops or the possibility of short-circuiting groups of instruments in a loop, there should be only one earth in a loop.

6. Connect the power supply and receiver loop wires to the “+” and “–” terminal connections.
7. Connect receivers (such as controllers, recorders, indicators) in series with a power supply and transmitter as shown in Figure 13.
8. Reinstall the cover onto the housing by rotating it clockwise to seat the O-ring into the housing and then continue to hand tighten until the cover contacts the housing metal-to-metal. If cover locks are present, lock the cover per the procedure described in “Cover Locks” on page 16.
9. If wiring additional transmitters to the same power supply, repeat Steps 1 through 8 for each additional transmitter. The setup with multiple transmitters connected to a single power supply is shown in Figure 14.

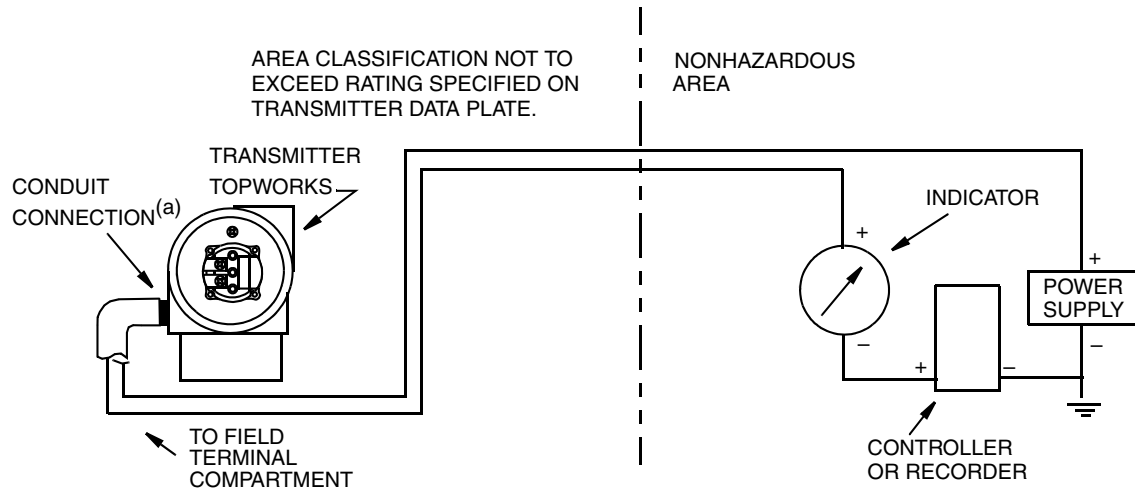

(A) RUN CONDUIT DOWN TO AVOID MOISTURE BUILDUP IN TERMINALS COMPARTMENT.

Figure 13. Loop Wiring

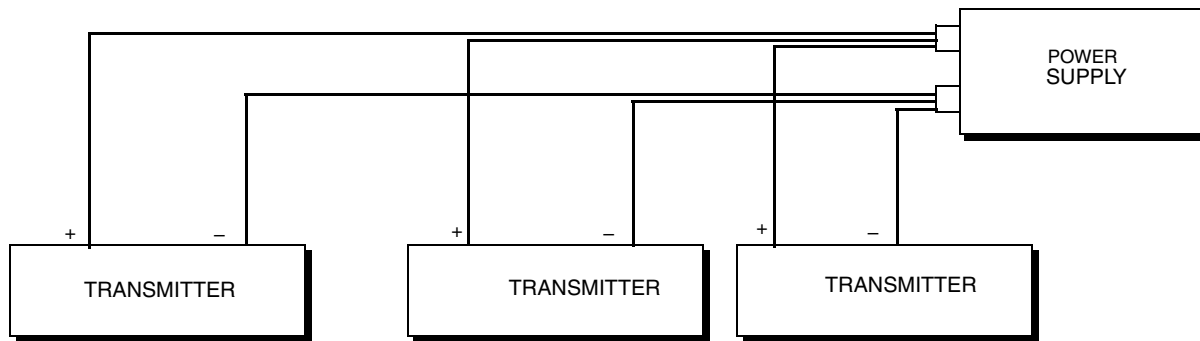

Figure 14. Wiring Several Transmitters to a Common Power Supply

3. Operation Via Local Display

A local display, as shown in Figure 15, has two lines of information. The upper line is a 5-digit numeric display (4-digit when a minus sign is used); the lower line is a 7-digit alphanumeric display. The display provides local indication of measurement information and a means for performing calibration and configuration, viewing the database, and testing the display via a 2-button (**Next** and **Enter**) keypad. You can access these operations by means of a multi-level menu system. Entry to the Mode Select menu is made (from normal operating mode) by pressing the **Next** button. You can exit this menu, restore your prior calibration or configuration, and return to the normal operating mode at any time by going to **Cancel** and pressing the **Enter** button.

The following items can be selected from this menu: Calibration (**CALIB**); Configuration (**CONFIG**); and Testing the display (**TST DSP**). The top level structure diagram is shown in Figure 16.

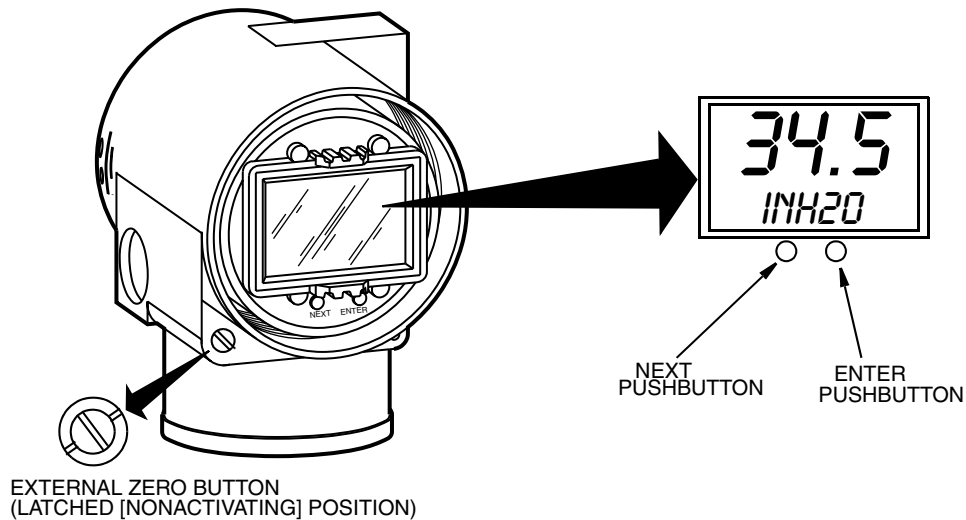

Figure 15. Local Display Module

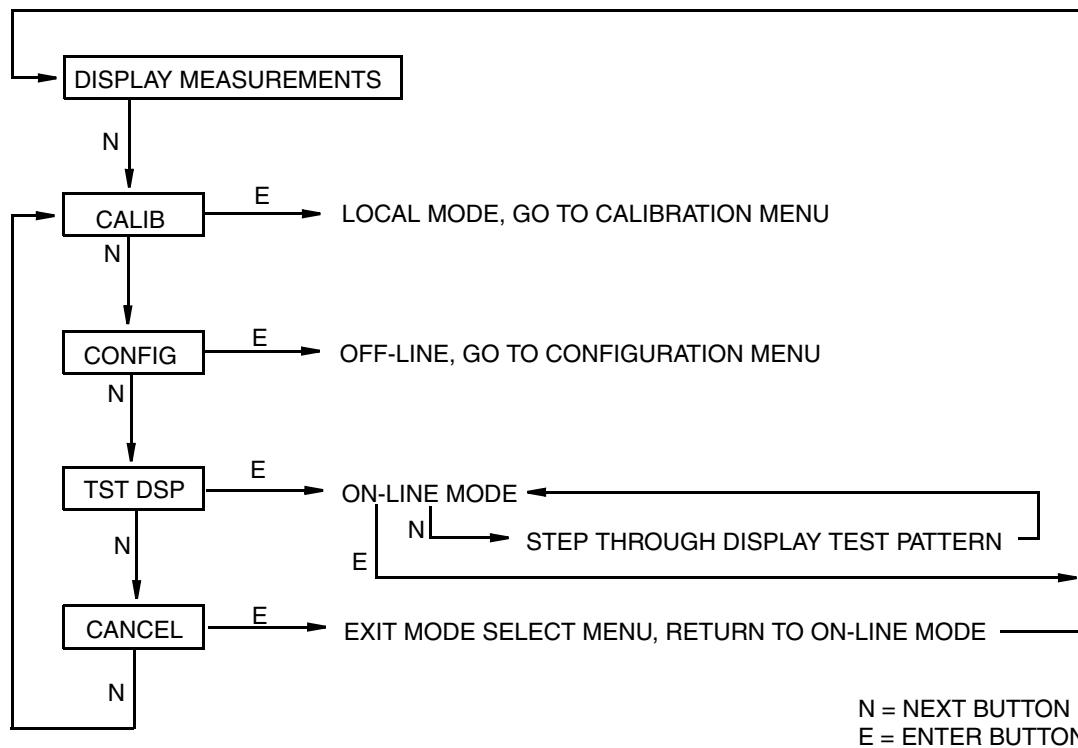

Figure 16. Top Level Structure Diagram

Testing the Display

You can access the Test Display mode by the same multi-level menu system that was used to enter Calibration and Configuration mode. Entry to the Mode Select menu is made (from normal operating mode) by pressing the **Next** button. The display reads **CALIB**, the first item on the menu. Press the **Next** button two times to get to the third item on the menu, **TST DSP**. Acknowledge your choice of this selection by pressing the **Enter** button. The display shows the first test segment pattern. You can step through the five patterns by repeated use of the **Next** button. You can abort the test at any time by pressing the **Enter** button. The five patterns are shown in Figure 17.

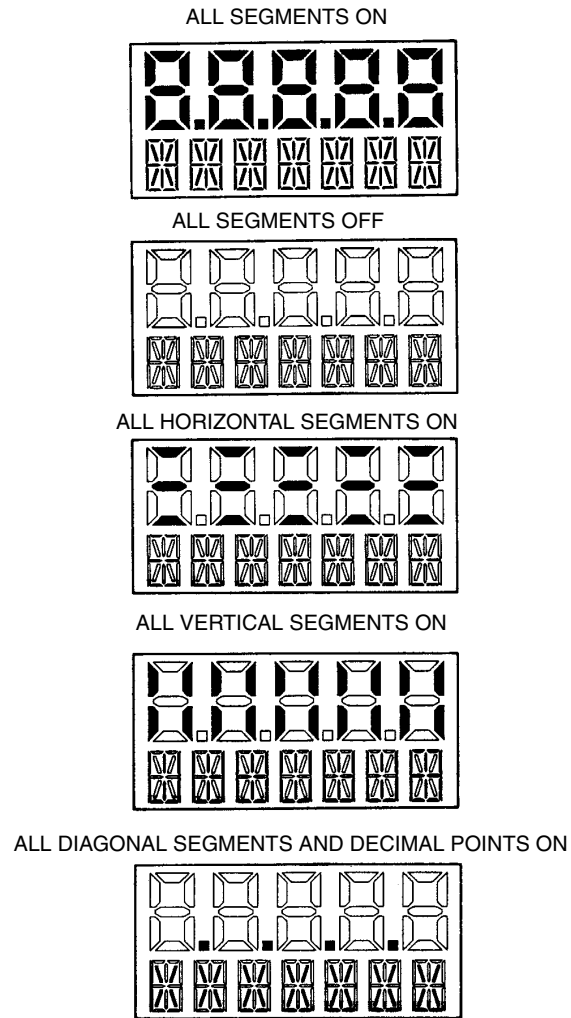

Figure 17. Display Test Segment Patterns

Error Messages

Table 3. Error Messages

| Message | Interpretation |
|------------|--|
| OVR RNG | Normalized calculation result greater than 2% above calibrated span. a. Overrange input; correct input condition. b. Bad span calibration; recalibrate span. c. Bad sensor connection; check electronics module to sensor connection. d. Defective or damaged sensor; replace sensor. |
| UND RNG | Normalized calculation result greater than 2% below calibrated zero. a. Underrange input; correct input condition. b. Bad zero calibration; recalibrate zero. c. Bad sensor connection; check electronics module to sensor connection. d. Defective or damaged sensor; replace sensor. |
| FDB ERR | CRC error detected in Factory Database on startup. a. Incorrect user database; replace sensor. b. Bad sensor connection; check electronics module to sensor. c. Defective or damaged sensor; replace sensor. |
| UDB ERR | CRC error detected in User Database on startup. a. Incorrect user database; reconfigure/recalibrate transmitter. b. Bad sensor connection; check electronics module to sensor. c. Defective or damaged sensor; replace sensor. |
| BAD IN1 | Normalized raw pressure input outside of limits. a. Extreme overrange or underrange input; correct input condition. b. Bad calibration; recalibrate transmitter. c. Bad sensor connection; check electronics module to sensor. d. Defective or damaged sensor; replace sensor. |
| BAD IN3 | Normalized raw temperature input outside of limits. a. Bad sensor connection; check electronics module to sensor. b. Defective or damaged sensor; replace sensor. |
| BAD KEY | Invalid keypress detected. a. Pressing Enter when transmitter is on-line. b. Pressing Next or Enter while WAIT is displayed; try again after WAIT message has cleared. |

4. Calibration

NOTE

1. For best results in applications where high accuracy is required, rezero the transmitter output once it has stabilized at the final operating temperature.
 2. Zero shifts resulting from position effects and/or static pressure effects can be eliminated by rezeroing the transmitter output.
 3. After calibrating transmitters operating with a 4 to 20 mA (or 1 to 5 V dc) output signal, check the underrange and overrange output values to ensure that they extend beyond 4 and 20 mA (or 1 and 5 V dc) respectively.
-

General Calibration Notes

1. Each transmitter is factory characterized over its full rated pressure range. One benefit of this process is that every transmitter can measure any applied pressure within its range limits regardless of the calibrated range. The applied pressure is measured and converted into an internal digital value of pressure. This digital value of pressure is always available whether the transmitter is calibrated or not. Calibration assures that the transmitter rated accuracy is achieved over the calibrated range.
2. The internal digital value of pressure can be displayed on the local display, and converted to a 4 to 20 mA analog output signal.
3. Each transmitter is factory calibrated to either a specified or a default calibrated range. This calibration optimizes the accuracy of the internal digital value of pressure over that range. If no range is specified, the default range is zero to the sensor upper range limit (URL).
4. There is an independent trim on the digital-to-analog conversion stage. This trim allows for slight adjustment of the 4 and 20 mA outputs. This compensates for any slight difference that exists between the transmitter mA output and an external reference device which is measuring the current.
 - ◆ The mA trim does not affect the calibration or the reranging of the transmitter and does not affect the internal digital value of pressure or the transmission or display of measured pressure.
 - ◆ The mA trim can be done with or without pressure applied to the transmitter.
5. The transmitter database has configurable values for both lower range value (LRV) and upper range value (URV). These stored values are used for two functions:
 - a. Defining the Calibrated Range:
 - ◆ When either **CAL LRV** or **CAL URV** is initiated from the pushbuttons, the transmitter expects that the pressure applied at the time the button is pressed is equal to the LRV or URV value respectively.

- ◆ This function trims the internal digital value of pressure; that is, it performs a calibration based on the application of accurate pressures equal to the values entered for LRV and URV in the transmitter database.
- ◆ This function also sets the 4 and 20 mA output points; that is, the 4 and 20 mA points correspond to the values of LRV and URV in the database.
- ◆ If the transmitter is configured for reverse range, the 20 and 4 mA points correspond to the LRV and URV respectively.

b. **Reranging Without the Application of Pressure:**

- ◆ Since the transmitter continually determines an internal digital value of the measured pressure from the lower range limit (LRL) to the upper range limit (URL), the 4 and 20 mA output points can be assigned to any pressure values (within the span and range limits) without application of pressure.
- ◆ The reranging function is accomplished by entering new database values for LRV and URV.
- ◆ Reranging does not affect the calibration of the transmitter; that is, it does not affect the optimization of the internal digital value of pressure over a specific calibrated range.
- ◆ If the reranged LRV and URV are not within the calibrated range, the measured values may not be as accurate as when they are within the calibrated range.

6. **LCD Indicator**

- ◆ The display can show any measured pressure in selected units regardless of the calibrated range and the values of LRV and URV (within the limits of the transmitter and display). The display can also be 0 to 100 percent.
- ◆ If the measured pressure is outside the range established by the LRV and URV values in the database, the display shows the measurement but also continually blinks to indicate that the measurement is out of range. The current signal is saturated at either the low or high overrange limit respectively but the display continually shows the pressure.
- ◆ Custom flow units for display, including 0 to 100 percent, are used when the transmitter is in square root mode.

7. **Zeroing the Transmitter**

- ◆ Zeroing does not affect the span.
- ◆ When the transmitter is zeroed to compensate for installed position effect, the transmitter may have either LRV pressure applied (**CAL LRV**) or zero pressure applied (**CAL AT0**). If the range is zero-based, either method produces the same result. However, if the range is not zero-based, it is advantageous to have both methods available.

For example, consider a pressure transmitter having a range of 50 to 100 psig. If it is not feasible to vent the transmitter to atmosphere for zeroing, it may be zeroed while the LRV pressure of 50 psi is applied by using the **CAL LRV** function. On the other hand, if the transmitter has been installed but there is no pressure in the

process line yet, it can be zeroed while open to atmosphere by using the **CAL AT0** function.

- a. Zeroing with LRV Pressure Applied (**CAL LRV**):
 - ◆ Before using this zeroing function, apply a pressure to the transmitter equal to the value of LRV stored in the transmitter database.
 - ◆ When you zero the transmitter, the internal digital value of the pressure is trimmed to be equal to the value of LRV stored in the database and the mA output set to 4 mA.
 - ◆ If zeroing is done when the applied pressure is different from the LRV pressure value in the database, the internal digital value of pressure is biased by the difference in the values but the output is still set at 4 mA.
 - ◆ The **CAL LRV** (and **CAL URV**) function should be used when calibrating a transmitter for a specific range with known input pressures applied for the LRV and URV.
- b. Zeroing a Gauge Pressure Transmitter with Zero Pressure Applied (**CAL AT0**):

— **NOTE** —

Do **not** use the **CAL AT0** function with an absolute pressure transmitter. If an absolute pressure transmitter is vented to atmosphere, it does **not** have zero pressure applied but instead has the barometric pressure (approximately 14.7 psia) applied.

- ◆ Make sure that the applied pressure is at zero. This means venting the transmitter to atmosphere.
 - ◆ When you zero the transmitter, the internal digital value of the pressure is trimmed to be equal to zero and the mA output set to an appropriate value such that the mA output is a normal 4 mA when the LRV pressure is applied later.
- c. Zeroing an Absolute Pressure Transmitter

To zero an absolute pressure transmitter, the LRV can be temporarily set to the barometric pressure and a CAL LRV function performed with the transmitter vented to atmosphere. Then, the LRV can be set back to the proper value.

Calibration Setup

The following sections show setups for field or bench calibration. Use test equipment that is at least three times as accurate as the desired accuracy of the transmitter.

— **NOTE** —

It is not necessary to set up calibration equipment to rerange the transmitter to a different range. The transmitter can be accurately reranged by simply changing the lower range value and the upper range value, which are stored in the transmitter database.

Setup of Electronic Equipment

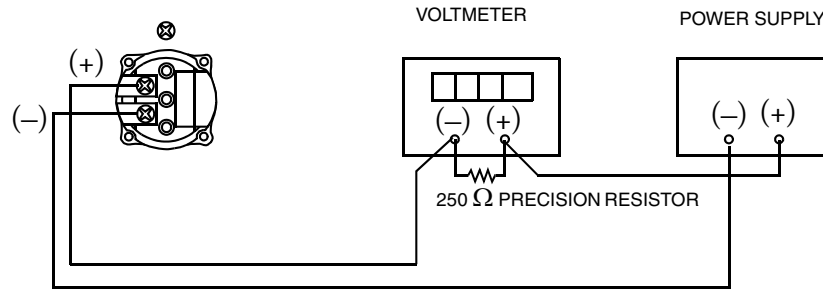

Resistor: 250 Ω, ±0.01%, 1 W minimum (Part No. E0309GY)
 Power Supply: Refer to Figure 12
 Digital Voltmeter: readings from 1.000 to 5.000 V dc

Figure 18. 4 to 20 mA Output Calibration Setup of Electronic Equipment

Field Calibration Setup

Field calibration is performed without disconnecting the process piping. This is only possible if you have a shutoff valve between the process and the transmitter and the process covers vent screw option (-V1).

If the transmitter is to be removed from the process for calibration, refer to “Bench Calibration Setup” below.

An adjustable air supply and a pressure measuring device are required. For example, a dead weight tester or an adjustable clean air supply and pressure gauge can be used. The pressure source can be connected to the transmitter with pipe fittings or it can be connected to the vent screw assembly using a calibration screw. The calibration screw has a Polyflo fitting and can be used for pressures up to 700 kPa (100 psi). It is available as Foxboro Part Number F0101ES.

To set up the equipment, refer to Figure 19 and then use the following procedure:

1. Close the shutoff valve between the process and the transmitter.
2. If a calibration screw is being used, remove the vent screw and replace it with the calibration screw. Connect the pressure source to the calibration screw using 6 x 1 mm or 0.250 inch tubing.
 If a calibration screw is **not** being used, remove the drain plug or the entire vent screw assembly (as applicable) from the high pressure side of the transmitter. Connect calibration tubing using a suitable thread sealant.
3. If calibrating the output signal, also connect equipment as shown in "Setup of Electronic Equipment."

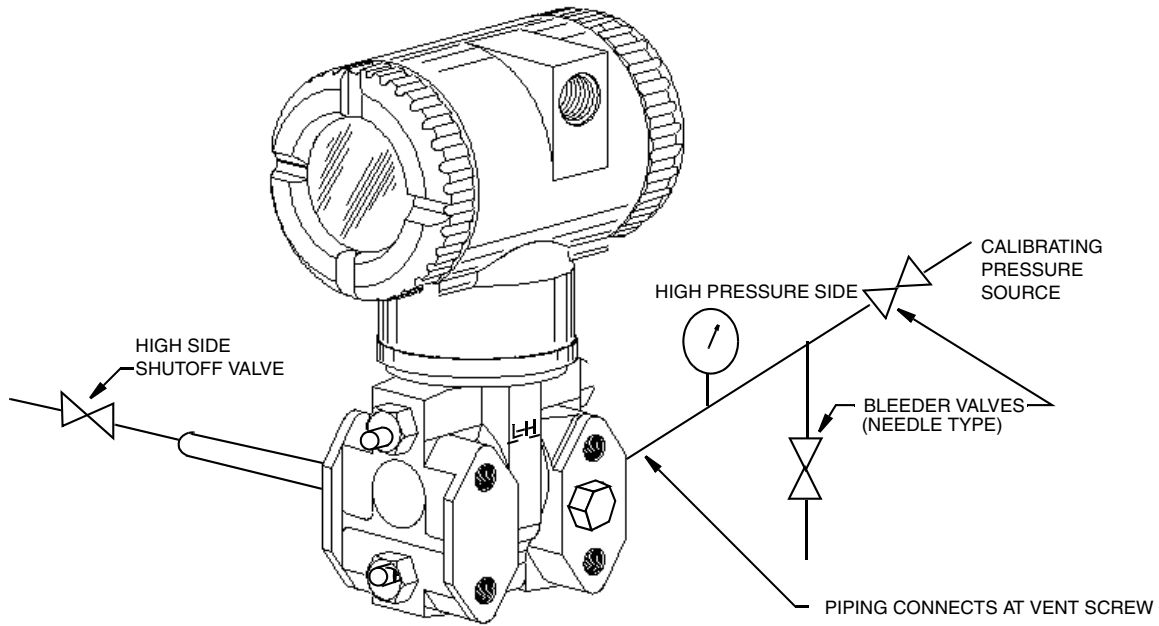

Figure 19. IAP20 and IGP20 Field Calibration Setup

Bench Calibration Setup

The bench calibration setup requires disconnecting the process piping. For calibration setup without disconnecting the process piping, refer to “Field Calibration Setup” above.

The input setup is shown in Figure 20. Connect the input piping to the high pressure side of the transmitter as shown. Vent the low pressure side of the transmitter.

If calibrating the output signal, also connect equipment as shown in "Setup of Electronic Equipment."

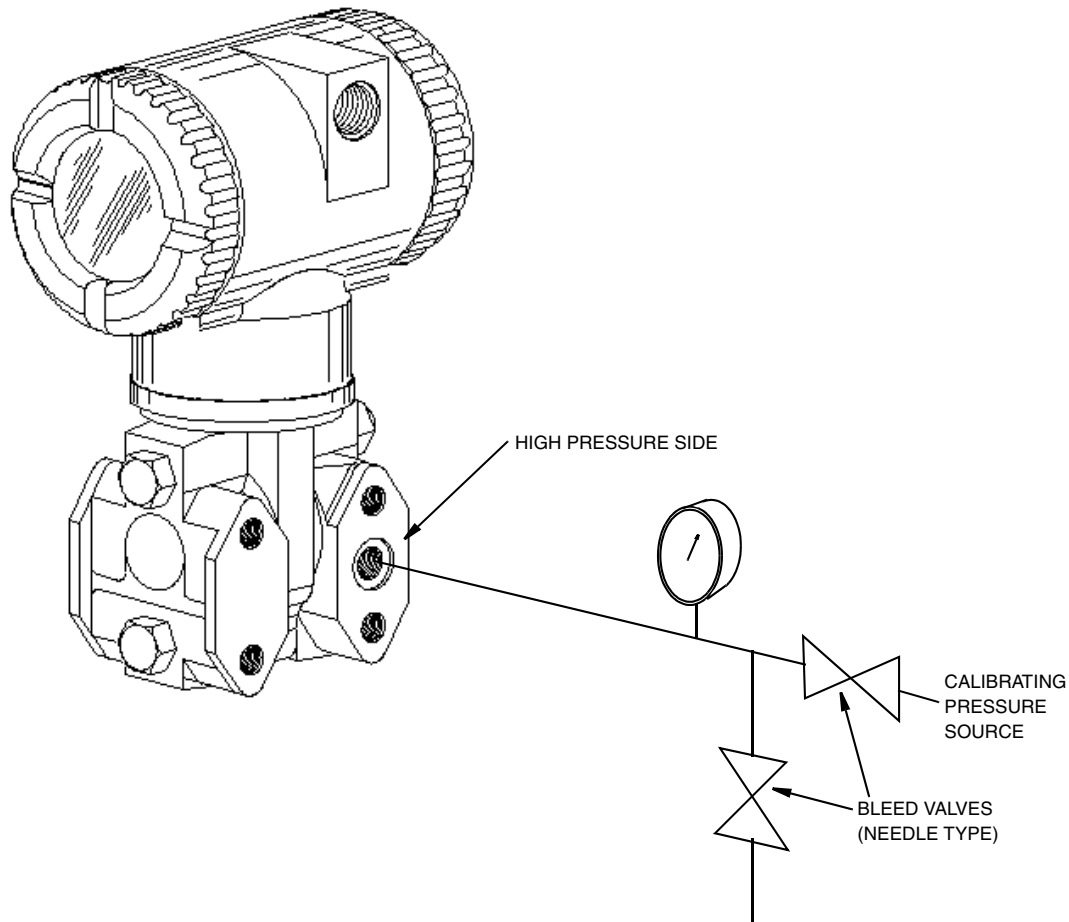

Figure 20. Bench Calibration Setup

Calibration Using the Local Display

To access the Calibration mode (from normal operating mode), press the **Next** button. The display reads **CALIB**, the first item on the menu. Acknowledge your choice of this selection by pressing the **Enter** button. The display shows the first item in the Calibration menu.

— NOTE —

During calibration, a single change could affect several parameters. For this reason, if an entry is entered in error, re-examine the entire database or use the **Cancel** feature to restore the transmitter to its starting configuration and begin again.

Table 4. Calibration Menu

| Item | Description |
|--|---|
| CAL AT0 | Calibrate with zero pressure. |
| CAL LRV | Calibrate with pressure at 0% of transmitter range (LRV). |
| CAL URV | Calibrate with pressure at 100% of transmitter range (URV). |
| ADJ 4MA | Adjust nominal 4 mA output. |
| ADJ20MA | Adjust nominal 20 mA output. |
| ADJ 4MA causes the following four submenus. | |
| A 4mAΔΔ | Increase 4 mA output by large step. |
| A 4mA∇∇ | Decrease 4 mA output by large step. |
| A 4mAΔ | Increase 4 mA output by small step. |
| A 4mA∇ | Decrease 4 mA output by small step. |
| ADJ 20MA causes the following four submenus. | |
| A 20mAΔΔ | Increase 20 mA output by large step. |
| A 20mA∇∇ | Decrease 20 mA output by large step. |
| A 20mAΔ | Increase 20 mA output by small step. |
| A 20mA∇ | Decrease 20 mA output by small step. |

NOTE

1. It is not necessary to use the **ADJ4MA** or **ADJ20MA** menu selections unless there is a plant requirement to make the 4 and 20 mA output values exactly match readings on certain plant calibration equipment and the “zero” and “span” operations done result in a small but unacceptable difference between the transmitter mA output and the test equipment mA readout values.
 2. The transmitter can be reranged without the application of pressure.
-

Proceed to calibrate your transmitter by using the **Next** key to select your item and the **Enter** key to specify your selection per Figure 21. At any point in the calibration you may **Cancel**, restore your prior calibration and return to the on-line mode or **Save** your new calibration.

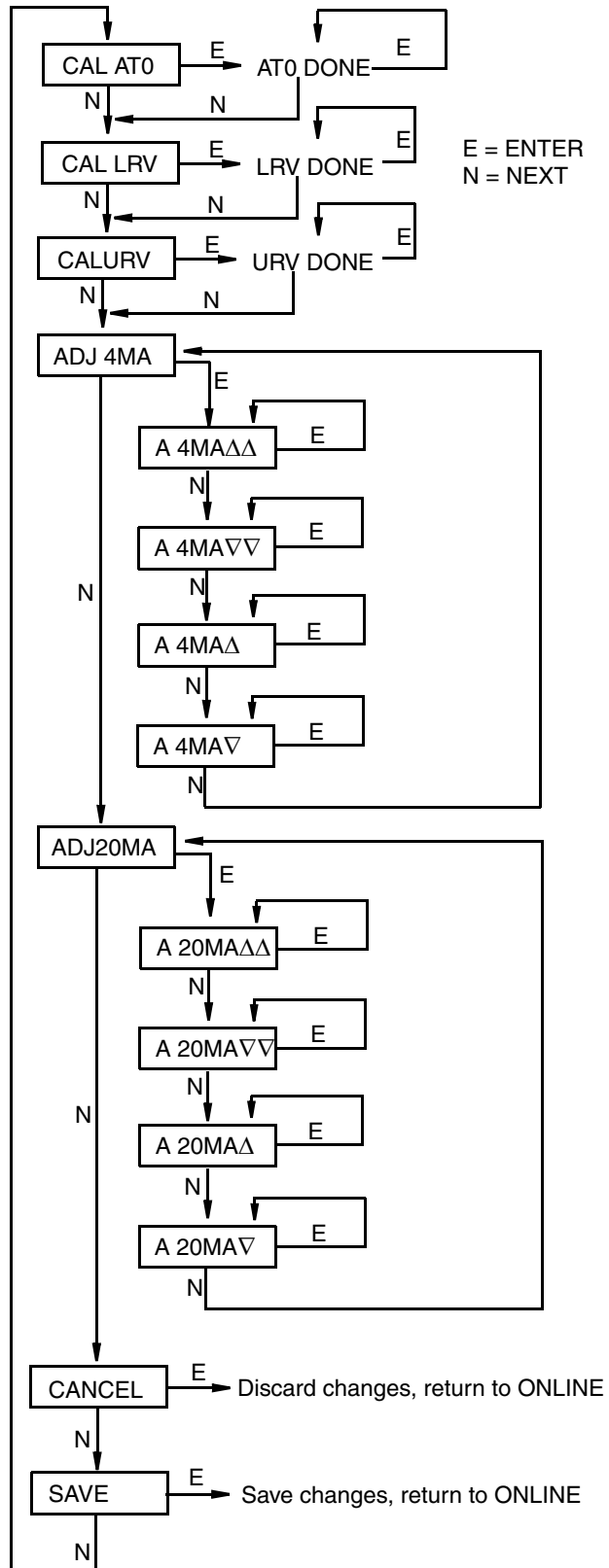

CAL AT0: To set or reset the zero point at zero differential pressure, apply zero differential pressure to the transmitter and, at display of **CAL AT0**, press **Enter**. This can be done whether LRV is zero or not. Completion is indicated by the display **AT0 Done**.

CAL LRV: To set or reset 0% of range input, apply differential pressure to the transmitter equal to the lower range value (LRV) in the transmitter database and, at display of **CAL LRV**, press **Enter**. Completion is indicated by the display **LRV Done**.

CAL URV: To set or reset 100% of range input, apply differential pressure to the transmitter equal to the upper range value (URV) in the transmitter database and, at display of **CAL URV**, press **Enter**. Completion is indicated by the display **URV Done**.

ADJ4mA: If you configured your transmitter operating mode as 4 to 20 mA, you can adjust the 4 mA output by going to **ADJ4mA** using the **Next** button and press **Enter**. This menu item is bypassed if you configured your transmitter operating mode as digital.

To increase the 4 mA output by a large (0.025 mA) step, press **Enter** at the display **A 4mAΔΔ**. To decrease it by a large step, go

Figure 21. Calibration Structure Diagram

Zero Adjustment Using External Zero Button

An optional external zero adjustment mechanism in the electronics housing allows local “rezeroing” of the transmitter output without removing the electronics compartment cover. The mechanism is magnetically activated through the housing wall to prevent moisture from entering the enclosure. Zeroing is accomplished when the external zero button is depressed. The external zero button does a **CAL AT0** calibration (at zero pressure).

To use this feature:

1. Unlatch the external zero button by turning it 90° in a counterclockwise direction so that the screwdriver slot lines up with the two holes in the face of the adjacent part. Do **not** push the button in with the screwdriver while doing this.
2. Press the button with zero pressure applied to the transmitter.
3. The display indicates **ZEROED**. If **EX ZERO** is disabled, or the transmitter is not on-line, the display reads **Bad Key**.
4. If additional rezeroing is required, wait 20 seconds and repeat Step 2.
5. Relatch the external zero button by turning it 90° in a clockwise direction to prevent accidental pressing of the button. Do **not** push the button in with the screwdriver while doing this.

Error Messages

Table 5. Error Messages

| Message | Interpretation |
|---------|--|
| BAD KEY | Pressing External Zero button with EX ZERO disabled or transmitter not on-line. |
| LOLIMIT | 4 mA or 20 mA calibration adjustment has reached lower limit. a. Improper calibration setup; correct setup. b. Bad D/A converter; replace electronics module. |
| HILIMIT | 4 mA or 20 mA calibration adjustment has reached upper limit. a. Improper calibration setup; correct setup. b. Bad D/A converter; replace electronics module. |
| BADZERO | Recalculation of offset during CAL AT0 , CAL LRV , or EX ZERO resulted in out of range value. a. Applied pressure too high during operation. b. Improper calibration setup. |
| BADSPAN | Recalculation of slope during CAL URV operation resulted in out of range value. a. Applied pressure too low during CAL URV operation. b. Improper calibration setup. |

5. Configuration

You can access the Configuration mode by the same multi-level menu system that was used to enter Calibration mode. Entry to the Mode Select menu is made (from normal operating mode) by pressing the **Next** button. The display reads **CALIB**, the first item on the menu. Press the **Next** button again to get to the second item on the menu, **CONFIG**. Acknowledge your choice of this selection by pressing the **Enter** button. The display shows the first item in the Configuration menu. You can then configure items shown in the following table. The initial factory configuration is also given in this table.

— **NOTE** —

During configuration, a single change may affect several parameters. For this reason, if an entry is entered in error, re-examine the entire database or use the **Cancel** feature to restore the transmitter to its starting configuration and begin again.

Table 6. Configuration Menu

| Item | Description | Initial Factory Configuration ^(a) |
|---------|---|--|
| EX ZERO | External zero: enable or disable | Disable |
| OUT DIR | Output direction: forward or reverse | Forward |
| OUTMODE | Output: linear ^(b) | Linear |
| OUTFAIL | Fail mode output: low or high | High |
| DAMPING | Damping: none, 2-, 4-, or 8-seconds | None |
| DISPEGU | Display measurement in EGU or in percent of span | Use EGU |
| EGU SEL | Engineering units for calibrated range and display: select from list. | Per Sales Order |
| EGU LRV | Set Lower Range Value (LRV) | Per Sales Order |
| EGU URV | Set Upper Range Value (URV) | Per Sales Order |

(a) Default settings. If optional feature “-C2” is specified, the initial factory configuration is custom per order.

(b) Square root is not applicable to absolute pressure, gauge pressure, or flange level measurement.

Proceed to configure your transmitter by using the **Next** key to select your item and the **Enter** key to specify your selection per the following table. At any point in the configuration you may **Cancel** your changes and return to the on-line mode or **Save** your changes.

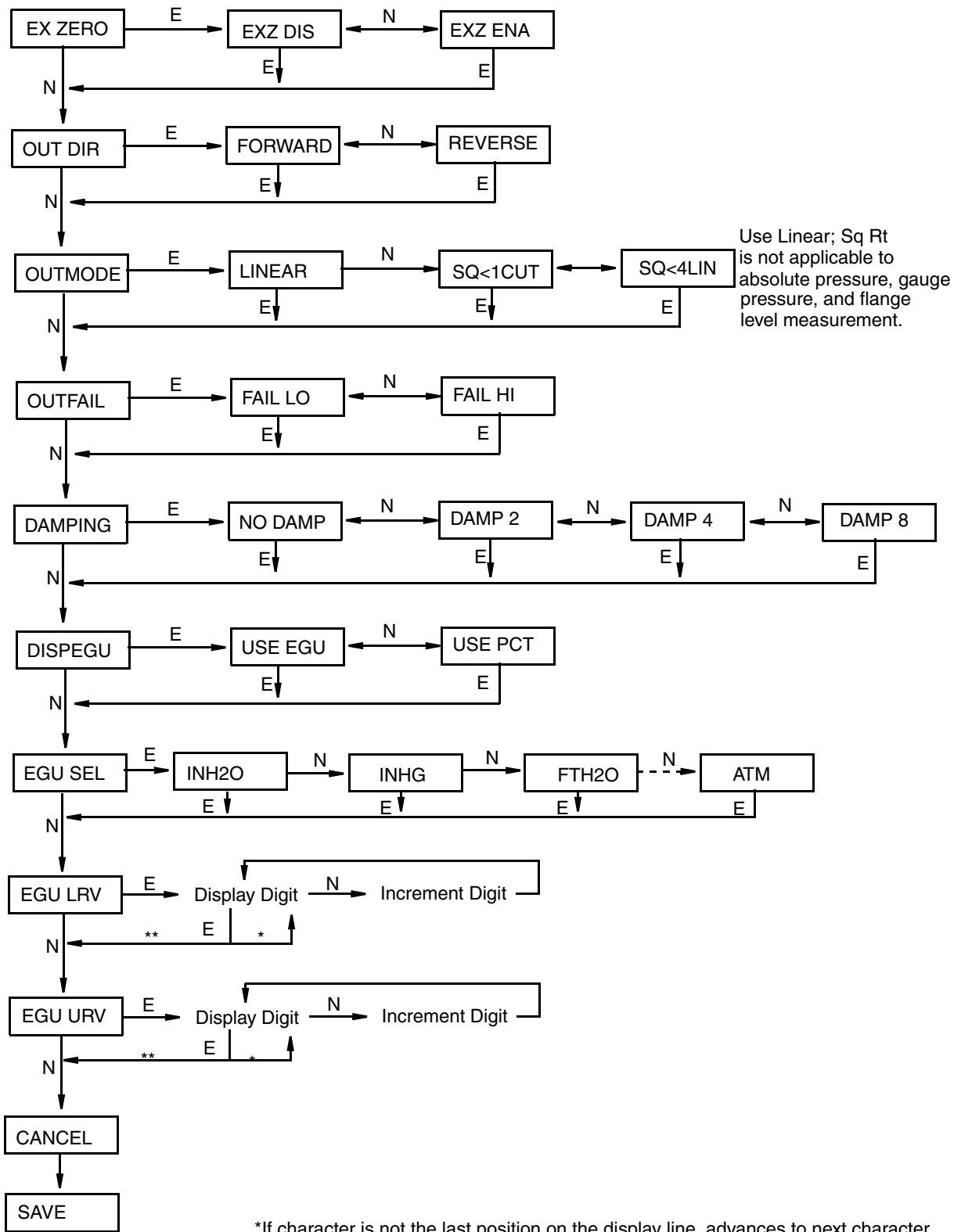

Figure 22. Configuration Structure Diagram

Commentary on Configuration Structure Diagram

In general, use the **Next** button to select an item and the **Enter** button to specify a selection.

EX ZERO:

The External Zero feature allows the optional external zero pushbutton to be disabled for additional security. To configure this feature, go to **EX ZERO** with the **Next** button and press **Enter**. Use the **Next** button to select **EXZ DIS** or **EXZ ENA** and press **Enter**.

OUT DIR:

To configure the Output Direction, go to **OUT DIR** with the **Next** button and press **Enter**. Use the **Next** button to select **FORWARD** (4 to 20 mA) or **REVERSE** (20 to 4 mA) and press **Enter**.

OUTMODE:

To configure the mode of the output, go to **OUTMODE** with the **Next** button and press **Enter**. Use the **Next** button to select **LINEAR** and press **Enter**. **SQ<1CUT** (square root with cutoff below 1% of calibrated pressure range) or **SQ<4LIN** (square root with dual slope linear below 4% of calibrated pressure range) is not applicable to absolute pressure, gauge pressure, and flange level measurement.

OUTFAIL:

The Outfail feature provides high or low output with certain malfunctions. To configure the fail mode output, go to **OUTFAIL** with the **Next** button and press **Enter**. Use the **Next** button to select **FAIL LO** or **FAIL HI** and press **Enter**.

DAMPING:

To configure additional damping, go to **DAMPING** with the **Next** button and press **Enter**. Use the **Next** button to select **NO DAMP**, **DAMP 2**, **DAMP 4**, or **DAMP 8** and press **Enter**.

DISPEGU:

To configure the display to present the measurement in engineering units or percent of span, go to **DISPEGU** with the **Next** button and press **Enter**. Then use the **Next** button to select **Use EGU** or **Use Pct** and press **Enter**.

EGU SEL:

To configure engineering units for your calibrated range and display, go to **EGU SEL** with the **Next** button and press **Enter**. Because **OUTMODE** was configured as **LINEAR**, use the **Next** button to select one of the following units: **INH₂O**, **INHG**, **FTH₂O**, **MMH₂O**, **MMHG**, **PSI**, **BAR**, **MBAR**, **G/CM²**, **KG/CM²**, **PA**, **KPA**, **MPA**, **TORR**, or **ATM** and press **Enter**.

EGU LRV:

To configure the LRV, press **Enter** at the prompt **EGU LRV**. Use the **Next** button to toggle between a space or a minus and press **Enter**. Then use the **Next** button to step through the library of numerical characters to select the desired first digit, and press **Enter**. Your selection is entered and the second digit flashes. Repeat this procedure until you have entered your last digit. Then use the **Next** button to move the decimal point to its desired location and press **Enter**.

EGU URV:

Similar to EGU LRV immediately above.

Reranging the Transmitter

The transmitter can be reranged without application of pressure. Because measurement of absolute or gauge pressure is done in Linear mode, the procedure is simple; just reconfigure **EGU LRV** and **EGU URV**.

Character Lists

Table 7. Alphanumeric Character List

| Characters |
|-------------------------|
| space |
| * |
| + |
| – |
| / |
| 0 through 9 |
| < |
| > |
| A through Z (uppercase) |
| [|
| \ |
|] |
| Δ |
| - (underscore) |
| ∇ |

Table 8. Numeric Character List

| Characters |
|-------------|
| – |
| 0 through 9 |

Error Messages

Table 9. Error Messages

| Message | Interpretation |
|---------|--|
| BAD LRV | Entered value for EGU LRV is outside sensor limits. |

Table 9. Error Messages (Continued)

| Message | Interpretation |
|---------|--|
| BAD URV | Entered value for EGU URV is outside sensor limits. |
| BAD RNG | Recalculation of turndown during EGU LRV or EGU URV resulted in out of range value. Entered values for EGU LRV and/or EGU URV were either too close together or too far apart. |
| RNG>EGU | Recalculation of display value for EGU LRV or EGU URV resulted in out of range value. Selection of (linear) EGU units caused display to overflow. |
| LRVNOT0 | Attempting mode change from LINEAR to SQ<1CUT or SQ<4LIN when EGU LRV is not 0.0. |

6. Maintenance

—  **DANGER** —

For nonintrinsically safe installations, to prevent a potential explosion in a Division 1 hazardous area, de-energize transmitters before you remove threaded housing covers. Failure to comply with this warning could result in an explosion resulting in severe injury or death.

Parts Replacement

Parts replacement is generally limited to the electronics module assembly, housing assembly, sensor assembly, terminal block assembly, cover O-rings, and optional display. For part numbers relating to the transmitter and its options, see PL 009-007.

Replacing the Terminal Block Assembly

1. Turn off transmitter power source.
2. Remove the Field Terminals and the Electronics compartment covers by rotating them counterclockwise. Screw in cover lock if applicable.
3. Remove the digital display (if applicable) as follows: grasp the two tabs on the display and rotate it about 10° in a counterclockwise direction.
4. Remove the electronics module from the housing by loosening the two captive screws that secure it to the housing. Then pull the module out of the housing far enough to gain access to the cable connectors on the rear of the module.
5. Remove the four socket head screws securing the terminal block.
6. Disconnect the terminal block cable connector from the electronics module.
7. Remove the terminal block and the gasket under it.
8. Connect the new terminal block cable connector to the electronics module.
9. Install the new terminal block and new gasket and reinstall the four screws to 0.67 N·m (6 in·lb) in several even increments.
10. Reinstall the electronics module (and digital display if applicable).
11. Reinstall the covers onto the housing by rotating them clockwise to seat the O-ring into the housing and then continue to hand tighten until the each cover contacts the housing metal-to-metal. If cover locks are present, lock the cover per the procedure described in “Cover Locks” on page 16.
12. Turn on transmitter power source.

Replacing the Electronics Module

To replace the electronics module assembly, proceed as follows:

1. Turn off transmitter power source.
2. Screw in cover lock (if present) and remove the threaded electronics compartment cover by rotating it counterclockwise.
3. Remove the electronics module from the housing by loosening the two captive screws that secure it to the housing. These screws are located towards the sides of the housing. Then pull the module out of the housing.

— **! CAUTION** —

The electronics module is “one assembly” at this point and is electrically and mechanically connected to topworks with a flexible ribbon signal cable, a 2-wire power cable, and in some cases, a cable for an optional external zero pushbutton. Do **not** exceed the slack available in these cables when removing the assembled module.

4. Unplug all cable connectors from the rear of the electronics module, noting the location of each cable, and place the module on a clean surface.
5. Predetermine connector orientation, then insert the cable connectors into the replacement module. Replace the module in the housing and tighten the two screws that secure it to the housing.

— **NOTE** —

To rotate display, see “Positioning the Display” in the Installation section.

6. Reinstall the cover onto the housing by rotating it clockwise to seat the O-ring into the housing and then continue to hand tighten until the cover contacts the housing metal-to-metal. If cover locks are present, lock the cover per the procedure described in “Cover Locks” on page 16.
7. Turn on transmitter power source.

The module replacement procedure is now complete.

— **NOTE** —

The transmitter configuration is stored in the sensor assembly. Therefore, the configuration settings are retained when replacing the electronics module. Recalibration, however, is recommended.

Removing and Reinstalling the Housing Assembly

To remove and reinstall the housing assembly, proceed as follows:

1. Remove the electronics module per Steps 1 through 4 in the previous procedure.
2. If your housing has an anti-rotation screw, remove the red lacquer from the screw recess. Turn the screw three full turns counterclockwise.
3. If your housing has a retention clip, remove the red lacquer from the screw recess. Remove the screw completely, and slide the clip off the housing. Save the clip and screw for future use,
4. Remove the housing by rotating it counterclockwise (when viewed from the top). Use caution to avoid damaging the sensor cable.

5. Inspect the sensor O-ring for damage. If the O-ring is damaged, replace it with the appropriate O-ring. (See parts list for your transmitter). Lubricate the O-ring with silicone lubricant (Foxboro Part Number 0048130 or equivalent). Verify that the O-ring is situated in the groove of the neck.

— **! WARNING** —

Failure to reuse or install the proper O-ring for a CSA labeled product violates ANSI / ISA 12.27.01.

6. Feed the sensor cable through the housing neck into the electronics compartment.
7. Screw the housing onto the sensor neck until it bottoms. Do not over tighten. Be careful not to damage the sensor cable or dislodge the neck O-ring.
8. If your housing has an anti-rotation screw, engage the screw until it touches the sensor neck and back it off 1/8th turn. It is important that the screw is not touching the sensor. Fill the screw recess with red lacquer (Foxboro Part Number X0180GS or equivalent). the housing may then be rotated up to one full turn counterclockwise for optimum access.
9. If your housing has a retention clip, insert the clip over the boss in the housing neck so that the hole in the clip is aligned with the hole in the boss. Install the screw but do not tighten. Rotate the housing up to one full turn counterclockwise for optimum access. Tighten the retention clip screw and fill the screw recess with red lacquer (Foxboro Part Number X0180GS or equivalent). The housing can still be rotated for optimum access.
10. Reinstall the electronics module per Steps 5 through 7 in the previous procedure.

Replacing the Sensor Assembly

To replace the sensor assembly, proceed as follows:

1. Remove the electronics module as described above.
2. Remove the housing as described above.
3. Remove the process covers from sensor by removing two hex head bolts.
4. Replace the gaskets in the process covers.
5. Install the process covers and housing on the new sensor. Torque cover bolts to 100 N·m (75 lb·ft) in several even increments. Torque values are 68 N·m (50 lb·ft) when 316 ss bolts are specified; 75 N·m (55 lb·ft) when B7M bolts are specified.
6. Reinstall electronics module.
7. Pressure test the sensor and process cover assembly by applying a hydrostatic pressure of 150% of the maximum static and overrange pressure rating to both sides of the process cover/sensor assembly simultaneously through the process connections. Hold pressure for one minute. There should be no leakage of the test fluid through the gaskets. If leakage occurs, retighten the cover bolts per Step 5 (or replace the gaskets) and retest.

! CAUTION
 Perform hydrostatic test with a liquid and follow proper hydrostatic test procedures.

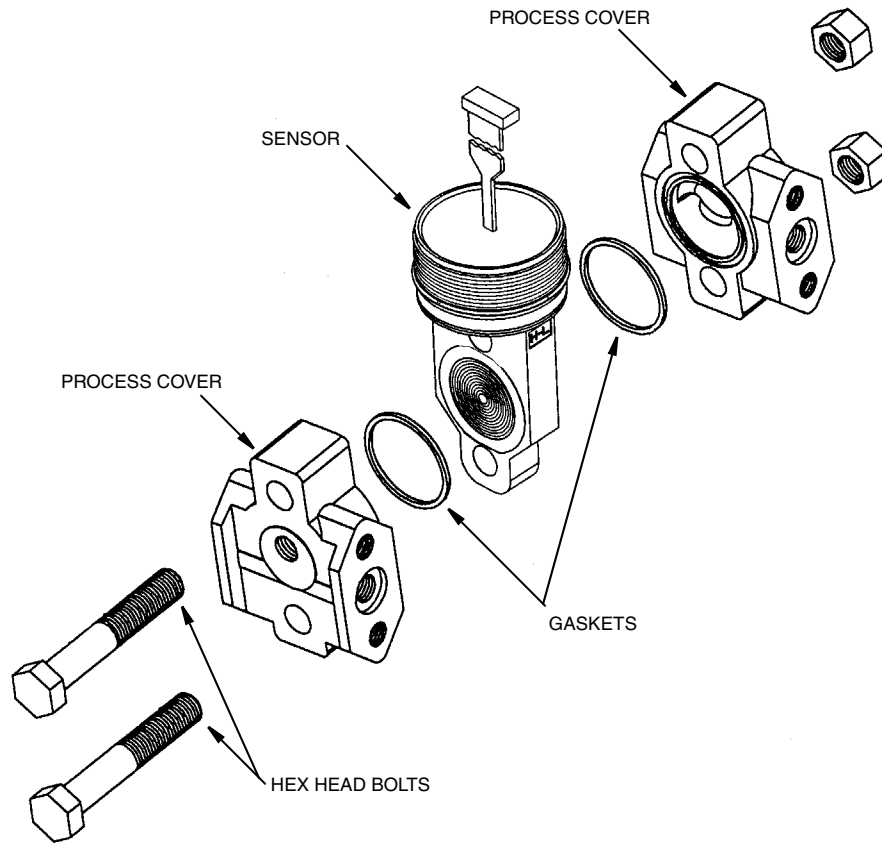

Figure 23. Replacing the Sensor Assembly

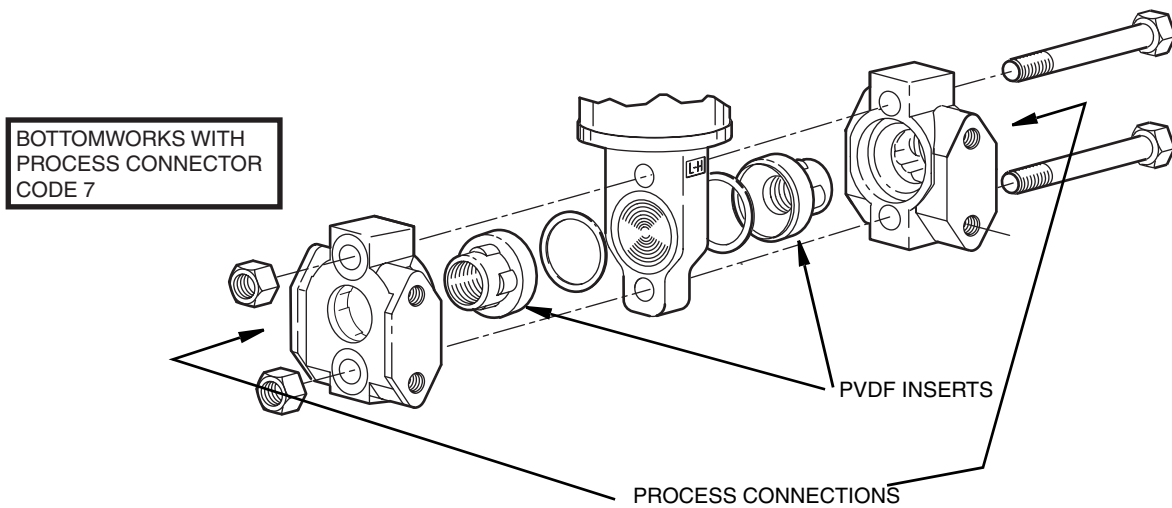

Figure 24. Replacing the Sensor Assembly (pvdf Inserts)

Rotating Process Covers for Venting

As received, your IASPT Transmitter provides sensor cavity draining without the need for side drain connections, regardless of whether the transmitter is mounted vertically or horizontally. Sensor cavity venting is provided by mounting the transmitter horizontally or with the optional vent screw (-V). However, if you did not specify this option, you can still achieve venting (instead of draining) with vertical mounting by rotating the process covers.

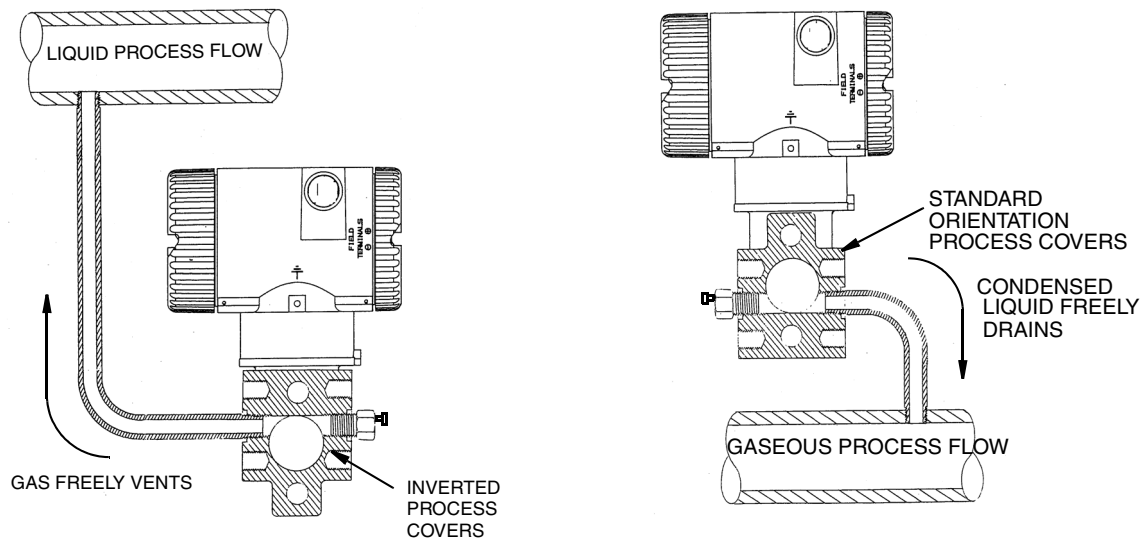

Figure 25. Sensor Cavity Venting and Draining

To rotate the process covers, refer to Figure 23 and proceed as follows:

1. Turn off the transmitter power source and remove the transmitter from the process.
2. Remove the process covers from sensor by removing two hex head bolts.
3. Replace gaskets in process covers.
4. Rotate the process covers so that the longer tab is at the bottom.
5. Reinstall process covers and bolts. Torque cover bolts to 100 N·m (75 lb·ft) in several even increments. Torque values are 68 N·m (50 lb·ft) when 316 ss bolts are specified; 75 N·m (55 lb·ft) when B7M bolts are specified.
6. Pressure test the sensor and process cover assembly by applying a hydrostatic pressure of 150% of the maximum static and overrange pressure (see “Standard Specifications” on page 3) to both sides of the process cover/sensor assembly simultaneously through the process connections. Hold pressure for one minute. There should be no leakage of the test fluid through the gaskets. If leakage occurs, retighten the cover bolts per Step 4 or replace the gaskets and retest.

! CAUTION
 Perform hydrostatic test with a liquid and follow proper hydrostatic test procedures.

Index

C

Calibration 25
Calibration Notes 25
Calibration Setup 27
Configuration 35
Cover Locks 16

D

Display, Positioning the 15

E

Error Messages
 Calibration 33
 Configuration 38
 Operation 24

H

Housing, Positioning the 14

I

Identification 2
Installation 11

M

Maintenance 41
Mounting 11

O

Operation 21

P

Parts Replacement 41
Piping, Typical Transmitter 12

R

Reference Documents 1
Reranging the Transmitter 38

S

Specifications

- Product Safety 8
- Standard 3

W

- Wiring 16

Z

- Zero Adjustment Using External Zero Button 33

ISSUE DATES

- DEC 2001
- OCT 2003
- APR 2004
- FEB 2005
- FEB 2006
- OCT 2007
- MAY 2010

Vertical lines to the right of text or illustrations indicate areas changed at last issue date.

Invensys Operations Management
5601 Granite Parkway Suite 1000
Plano, TX 75024
United States of America
<http://www.iom.invensys.com>

Global Customer Support
Inside U.S.: 1-866-746-6477
Outside U.S.: 1-508-549-2424 or contact
your local Invensys representative.
Email: support@invensys.com
Website: <http://support.ips.invensys.com>

Invensys, Foxboro, and I/A Series are trademarks of
Invensys plc, its subsidiaries, and affiliates.
All other brand names may be trademarks of their
respective owners.

Copyright 2001-2010 Invensys Systems, Inc.
All rights reserved