

**I/A Series<sup>®</sup> Pressure Transmitters**

**IAP20 Absolute Pressure and IGP20 Gauge Pressure  
with FOUNDATION<sup>™</sup> Fieldbus Communication  
Installation, Operation, Calibration, Configuration, and Maintenance**



i n v e n s i s

**Foxboro<sup>®</sup>**



# Contents

- Figures..... v
- Tables..... vii
- 1. Introduction ..... 1**
  - General Description ..... 1
  - Reference Documents ..... 2
  - Transmitter Identification ..... 3
  - Standard Specifications ..... 5
  - Product Safety Specifications ..... 11
    - ATEX and IECEx Warnings ..... 13
    - ATEX Compliance Documents ..... 13
    - IECEx Compliance Documents ..... 13
- 2. Installation ..... 15**
  - Transmitter Mounting ..... 15
  - Typical Transmitter Piping ..... 16
  - Positioning the Housing ..... 18
  - Positioning the Display ..... 19
  - Setting the Write Protect Jumper ..... 19
  - Cover Locks ..... 19
  - Wiring ..... 20
    - Accessing Transmitter Field Terminals ..... 20
    - Wiring Notes ..... 21
    - Wiring the Transmitter ..... 23
  - Installing the FOUNDATION Fieldbus Software ..... 24
- 3. Operation Via Local Display ..... 25**
  - Entering Numerical Values ..... 26
  - Viewing the Database ..... 27
  - Viewing the Pressure Range ..... 27
  - Testing the Display ..... 27
- 4. Calibration ..... 29**
  - Calibration Setup ..... 29
    - Field Calibration Setup ..... 29
    - Bench Calibration Setup ..... 30
  - Calibration Using the Optional Local Display ..... 31

Zero Adjustment Using External Zero Button .....	34
Calibration from a FOUNDATION Fieldbus Host .....	34
<b>5. Configuration.....</b>	<b>37</b>
Configuration Using the Optional Local Display .....	37
Character Lists .....	46
Configuration Using a FOUNDATION Fieldbus Host .....	46
Configuration Procedure Using a FOUNDATION Fieldbus Host .....	46
Configuring the Transducer Block .....	47
Configuring the Scaling Parameters in the Analog Input Block .....	47
Application Specific Configurations .....	50
Changing the Primary Range Values (Reranging) by Editing the Transducer Block Parameters .....	51
Disabling the Link Active Scheduler (LAS) .....	52
<b>6. Maintenance.....</b>	<b>53</b>
Troubleshooting .....	53
Simulation Mode .....	53
Restart .....	54
Switch Mode Checklist .....	55
Schedule Download Checklist .....	55
Block Errors .....	55
Interboard Communication Errors/Status .....	56
Parts Replacement .....	57
Replacing the Terminal Block Assembly .....	58
Replacing the Electronics Module Assembly .....	58
Removing and Reinstalling a Housing Assembly .....	60
Adding the Optional Display .....	60
Replacing the Sensor Assembly .....	61
Rotating Process Covers for Venting .....	63
<b>Appendix A. List of Parameters .....</b>	<b>65</b>

# Figures

1	Transmitter Identification .....	3
2	Top Level Structure Diagram .....	4
3	Minimum Allowable Absolute Pressure vs. Process Temperature with Fluorinert Fill Fluid .....	8
4	Pipe Mounting .....	15
5	Surface Mounting .....	16
6	Typical Transmitter Piping .....	17
7	Hot Process Piping .....	18
8	Housing Screw or Clip Location .....	18
9	Write Protection Jumper .....	19
10	Cover Lock Location .....	20
11	Accessing Field Terminals .....	20
12	Identification of Field Terminals .....	21
13	Wiring Diagram of Typical FOUNDATION Fieldbus Transmitter Installation .....	22
14	Local Display Module .....	25
15	Top Level Structure Diagram .....	26
16	Display Test Segment Patterns .....	28
17	IAP20 and IGP20 Field Calibration Setup .....	30
18	Bench Calibration Setup .....	31
19	Calibration Structure Diagram .....	32
20	Configuration Structure Diagram (1 of 3) .....	39
21	Configuration Structure Diagram (2 of 3) .....	40
22	Configuration Structure Diagram (3 of 3) .....	41
23	Simulation Jumper .....	53
24	Replacing the Electronics Module Assembly and Display .....	59
25	Replacing the Sensor Assembly .....	62
26	Replacing the Sensor Assembly (PVDF Inserts) .....	62
27	Sensor Cavity Venting and Draining .....	63



# Tables

1	Reference Documents .....	2
2	Minimum Supply Voltage Requirements .....	10
3	Electrical Safety Specifications .....	11
4	Minimum Supply Voltage Requirements .....	21
5	Parameters Configurable from the Local Display .....	37
6	Alphanumeric Character List .....	46
7	Numeric Character List .....	46
8	Unit names and Unit Codes .....	47
9	Pressure Applications .....	50
10	Open Tank Applications .....	51
11	Block Errors .....	55
12	Configuration Errors .....	56
13	FOUNDATION Fieldbus Parameters .....	65



# 1. Introduction

## General Description

The IAP20-F Intelligent Absolute Pressure and IGP20-F Intelligent Gauge Pressure Transmitters measure pressure by applying the pressure to a silicon strain gauge microsensor within the sensor assembly. This microsensor converts the pressure to a change in resistance, and the resistance change is converted to a digital signal proportional to the pressure. This measurement signal is transmitted to remote receivers over the same two wires that supply power to the transmitter electronics. These wires also carry two-way data signals between the transmitter and remote communication devices.

The IAP20 and IGP20 can be supplied with remote pressure seals.

The measurement signal is a FOUNDATION™ fieldbus digital signal for full communication with any FOUNDATION fieldbus host equipped with a FOUNDATION fieldbus interface module. The communication functionality permits you to reconfigure a transmitter from a remote FOUNDATION fieldbus host personal computer, or I/A Series system equipped with a FOUNDATION fieldbus interface module.

FOUNDATION fieldbus is an all-digital, serial, two-way communication system that runs at 31.25 kbps, interconnecting a fieldbus host and various field devices such as process sensors/transmitters, valves/actuators, and controllers — all connected in parallel to the same bus. Both ends of the bus must be terminated with standard characteristic impedance networks to minimize reflected signals. Power to all devices is supplied by a dc fieldbus power source connected anywhere on the bus.

---

**— NOTE**

The power supply must be a fieldbus-specific power supply.

---

The communication signals between a fieldbus host and all other bus-connected devices, which are superimposed on the dc power signal on the bus, are controlled according to a strict cycle schedule and protocol. During intervals when control and data signals are not being transmitted according to the schedule, the devices are free to communicate with each other for such functions as local PID control, trend recording/indicating, etc.

The FOUNDATION fieldbus uses “Function Blocks” (standardized automation functions) to implement measurement and control strategies. These blocks may be distributed throughout the array of devices in whatever manner is most efficient. A major advantage of the concept is that devices from many manufacturers may be intermixed in a seamless and integrated manner. Since all devices in a system connect to the same wire pair, the system requires less wire than comparable systems, fewer intrinsic safety barriers and fewer interface cards, resulting in significant cost savings.

The FOUNDATION fieldbus system used on the IAP20-F and IGP20-F implements the following blocks — Resource Block, Transducer Block, Analog Input (AI) Blocks, and Proportional Integral Derivative (PID) Block. The Resource Block contains all parameters needed to define the device description for the transmitter. The Transducer Block handles all configurable parameters that define the sensor, transmitter hardware, and manufacturer-specific data. The AI Blocks contain all configurable parameters needed to define the input data for use with the other function blocks. The PID Block contains parameters required for PID control.

## Reference Documents

*Table 1. Reference Documents*

Document	Description
Dimensional Prints	
DP 020-342	Dimensional Print – PSFLT Pressure Seals
DP 020-343	Dimensional Print – PSFPS and PSFES Pressure Seals
DP 020-345	Dimensional Print – PSFAR Pressure Seals
DP 020-347	Dimensional Print – PSTAR Pressure Seals
DP 020-349	Dimensional Print – PSISR Pressure Seals
DP 020-351	Dimensional Print – PSSCR Pressure Seals
DP 020-353	Dimensional Print – PSSCT Pressure Seals
DP 020-354	Dimensional Print – PSSSR Pressure Seals
DP 020-355	Dimensional Print – PSSST Pressure Seals
DP 020-446	Dimensional Print – IDP10, IDP25, and IDP50 Differential Pressure Transmitters
DP 020-447	Dimensional Print – IAP10 and IAP20 Absolute Pressure and IGP10, IGP20, IGP25, and IGP50 Gauge Pressure Transmitters
Parts Lists	
PL 009-007	Parts List – IAP20 Absolute and IGP20 Gauge Pressure Transmitters
Instructions	
MI 014-900	Instruction –Fieldbus Overview
MI 020-360	Instruction, Wiring Guidelines for Foxboro FOUNDATION fieldbus Transmitters
MI 020-369	Instruction – Pressure Seals
MI 020-427	Instruction – Intrinsic Safety Connection Diagrams and Nonincendive Circuits
MI 022-138	Instruction – Bypass Manifolds - Installation and Maintenance
Technical Information	
TI 37-75b	Technical Information – Transmitter Material Selection Guide
TI 037-097	Technical Information – Process Sealing of I/A Series Pressure Transmitters for use in Class 1, Zone 0, 1, and 2 Hazardous Locations

# Transmitter Identification

See Figure 1 for transmitter data plate contents. For a complete explanation of the Model Number code, see the parts list. The sensor board firmware version is identified on the top line of the local display when VIEW DB (View Database) is selected in the top level structure. See Figure 2.

*Figure 1. Transmitter Identification*

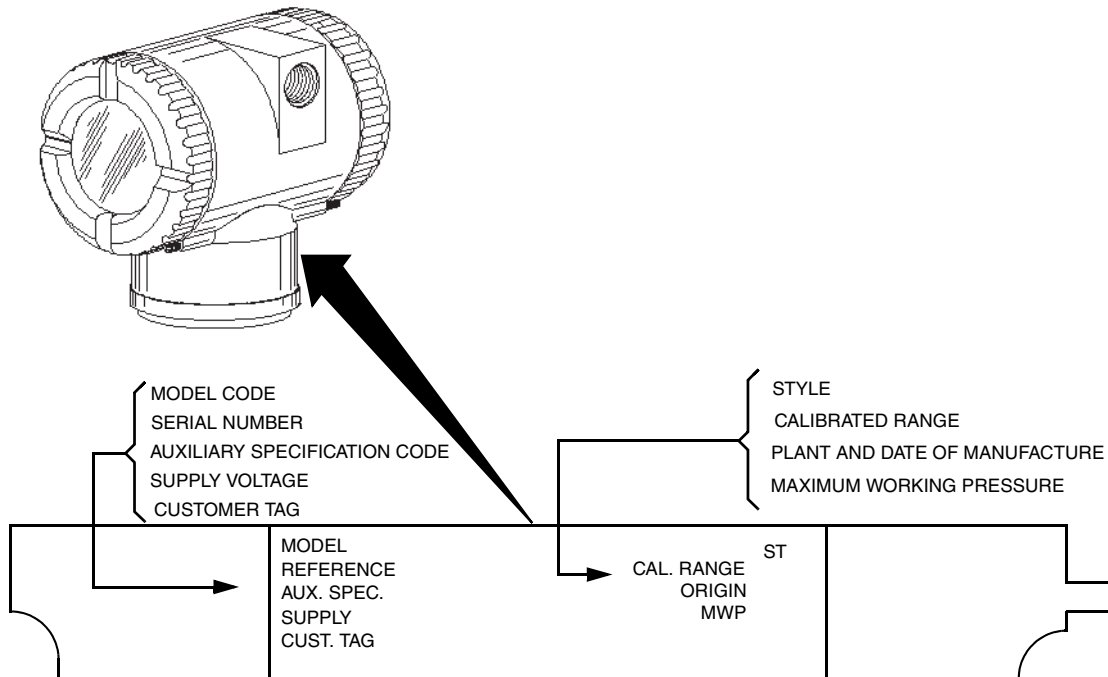
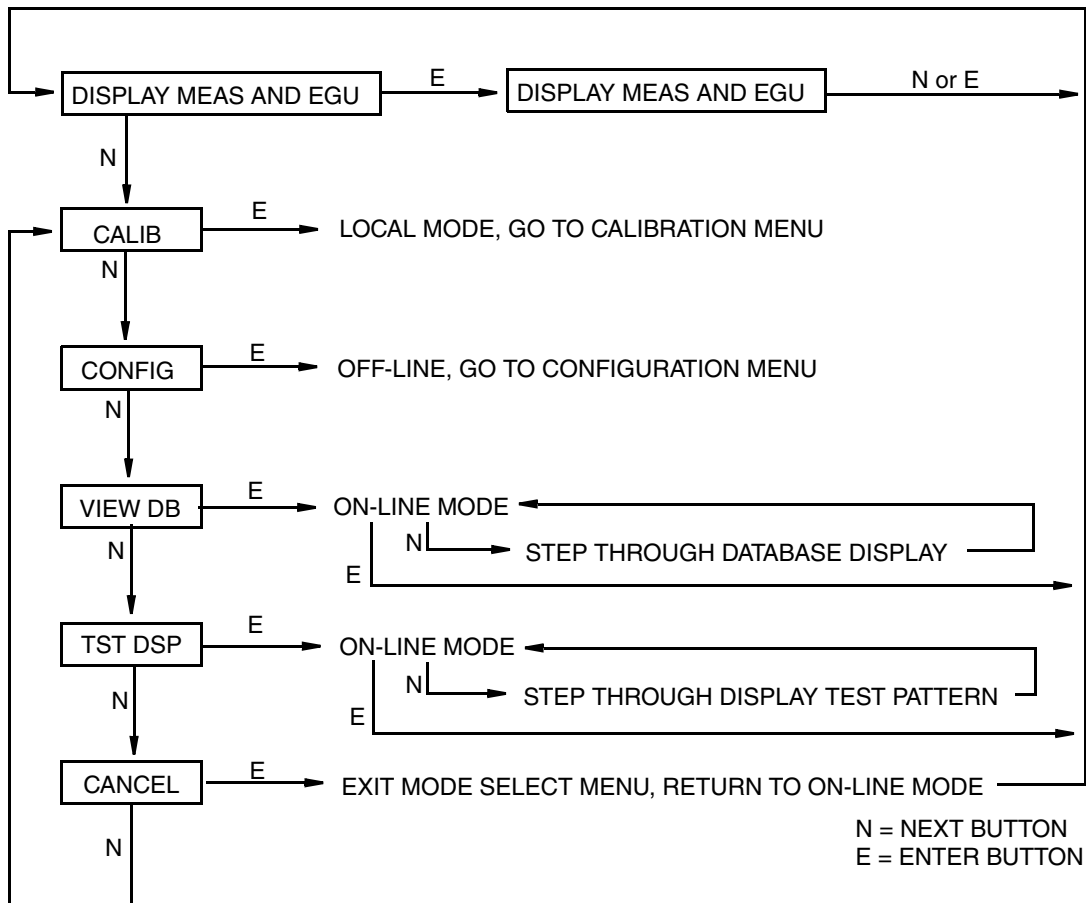
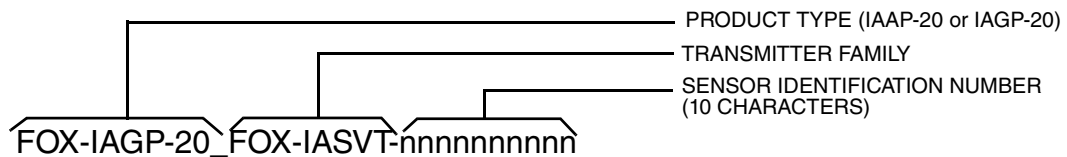

Figure 2. Top Level Structure Diagram



The initial PDTag of the device is:



The Device ID is:

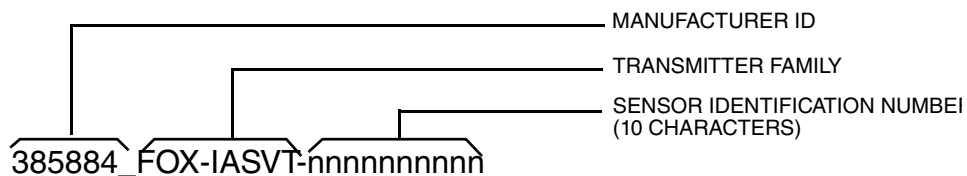

# Standard Specifications

## Operative Limits

Influence	Operative Limits
Sensor Body Temperature <sup>(a)</sup>	
Silicone Fill Fluid	-46 and +121°C (-50 and +250°F)
Fluorinert Fill Fluid	-29 and +121°C (-20 and +250°F)
pvc Inserts	-7 and +82°C (20 and 180°F)
Electronics Temperature With LCD Display	-40 and +85°C (-40 and +185°F -40 and +85°C (-40 and +185°F) <sup>(b)</sup>
Relative Humidity	0 and 100%
Supply Voltage	9 to 32 V dc
Mounting Position	No Limit
Pollution Degree	2
Installation Category (Overvoltage Category)	II
Vibration	6.3 mm (0.25 in) double amplitude from 5 to 15 Hz with aluminum housing and from 5 to 9 Hz with 316 ss housing. 0 to 30 m/s (0 to 3 “g”) from 15 to 500 Hz with aluminum housing and 0 to 10 m/s (0 to 1 “g”) from 9 to 500 Hz with 316 ss housing.

a. Refer to MI 020-369 for temperature limits with pressure seals.

b. Display updates are slowed and readability decreased at temperatures below -20°C (-4°F).

## Span and Range Limits

Span Limit Code	Span Limits <sup>(a)</sup>	Range Limits <sup>(a)</sup>
A <sup>(b,c)</sup>	0.12 and 7.5 kPa 0.5 and 30 inH <sub>2</sub> O 12 and 750 mmH <sub>2</sub> O	-7.5 and +7.5 kPa -30 and +30 inH <sub>2</sub> O -750 and +750 mmH <sub>2</sub> O
B	0.87 and 50 kPa 3.5 and 200 inH <sub>2</sub> O 87 and 5000 mmH <sub>2</sub> O	-50 and +50 kPa -200 and +200 inH <sub>2</sub> O -5000 and +5000 mmH <sub>2</sub> O
C	0.007 and 0.21 MPa 28 and 840 inH <sub>2</sub> O	-0.1 and +0.21 MPa -410 and +840 inH <sub>2</sub> O
D	0.07 and 2.1 MPa 10 and 300 psi 23 and 690 ftH <sub>2</sub> O	-0.1 and +2.1 MPa -14.7 and +300 psi -34 and +690 ftH <sub>2</sub> O
E	0.7 and 21 MPa 100 and 3000 psi	-0.1 and +21 MPa -14.7 and +3000 psi
F <sup>(b)</sup>	1.38 and 34.5 MPa 200 and 5000 psi	-0.1 and 34.5 MPa -14.7 and 5000 psi
(a) Values listed are in absolute or gauge pressure units, as applicable.		
(b) Applicable to IGP20 only.		
(c) Not available with pressure seals.		

## Maximum Overage Pressure and Proof Pressure

### ! CAUTION

1. Exceeding the overrange pressure limit for the transmitter can cause damage to the transmitter and degrade its performance.
2. The transmitter may be nonfunctional after application of the proof pressure.

Span Limit Code	Maximum Overage Pressure <sup>(a)</sup>	Proof Pressure <sup>(a,b)</sup>
A	25 MPa (3625 psi)	100 MPa (14500 psi)
B	25 MPa (3625 psi)	100 MPa (14500 psi)
C	25 MPa (3625 psi)	100 MPa (14500 psi)
D	25 MPa (3625 psi)	100 MPa (14500 psi)
E	31 MPa (4500 psi)	100 MPa (14500 psi)
F	52 MPa (7500 psi)	100 MPa (14500 psi)

(a) Values listed are in absolute or gauge pressure units, as applicable

(b) Meets ANSI/ISA Standard S82.03-1988.

The maximum overrange pressure and proof pressure may be different depending on the bolting material. Refer to the table below.

Transmitter Configuration (Bolting Material) <sup>(c)</sup>	Maximum Static and Overrange Pressure Rating <sup>(a,e)</sup>		Proof Pressure Rating <sup>(b)</sup>	
	MPa	Psi	MPa	Psi
Option “-B2” (17-4 PH ss), Option “-D3” or “-D7”	25	3625	100	14500
Option “B1” (316 ss) or Option “-D5”	15	2175	60	8700
Option “B3” (B7M)	20	2900	70	11150
Option “-D1”	16	2320	64	9280
Option “-D2”, “-D4”, “-D6”, or “-D8” <sup>(d)</sup>	10	1500	40	6000
Option “D9” (17-4 PH ss)	40	5800	100	14500

(a) Either side can be at higher pressure during overrange.

(b) Meets ANSI/ISA Standard S82.03-1988.

(c) -D1 = DIN Single ended process cover with M10 B7 bolting.

-D2 = DIN Double ended process cover with M10 B7 bolting

-D3 = DIN Single ended process cover with 7/16 in B7 bolting.

-D4 = DIN Double ended process cover with 7/16 in B7 bolting.

-D5 = DIN Single ended process cover with 7/16 in 316 ss bolting.

-D6 = DIN Double ended process cover with 7/16 in 316 ss bolting.

-D7 = DIN Single ended process cover with 7/16 in 17-4 ss bolting.

-D8 = DIN Double ended process cover with 7/16 in 17-4 ss bolting.

-D9 = DIN Single ended process cover with 7/16 in 17-4 ss bolting.

(d) Limited to operating temperatures ranging from 0 to 60°C (32 to 140°F).

(e) When Structure Codes 78/79 are used (pvdf insert in the Hi side process cover), the maximum overrange is 2.1 MPa (300 psi) and temperature limits are -7 and +82°C (20 and 180°F).

## Elevated Zero and Suppressed Zero

For applications requiring an elevated or suppressed zero, the maximum span and the upper and lower range limits of the transmitter can not be exceeded.

## Sensor Fill Fluid

Silicone Oil (DC 200) or Fluorinert (FC-43)

## Minimum Allowable Absolute Pressure vs. Process Temperature

With Silicone Fill Fluid: up to 120°C (250°F) at full vacuum.

With Fluorinert Fill Fluid: Refer to Figure 3.

**Figure 3. Minimum Allowable Absolute Pressure vs. Process Temperature with Fluorinert Fill Fluid**

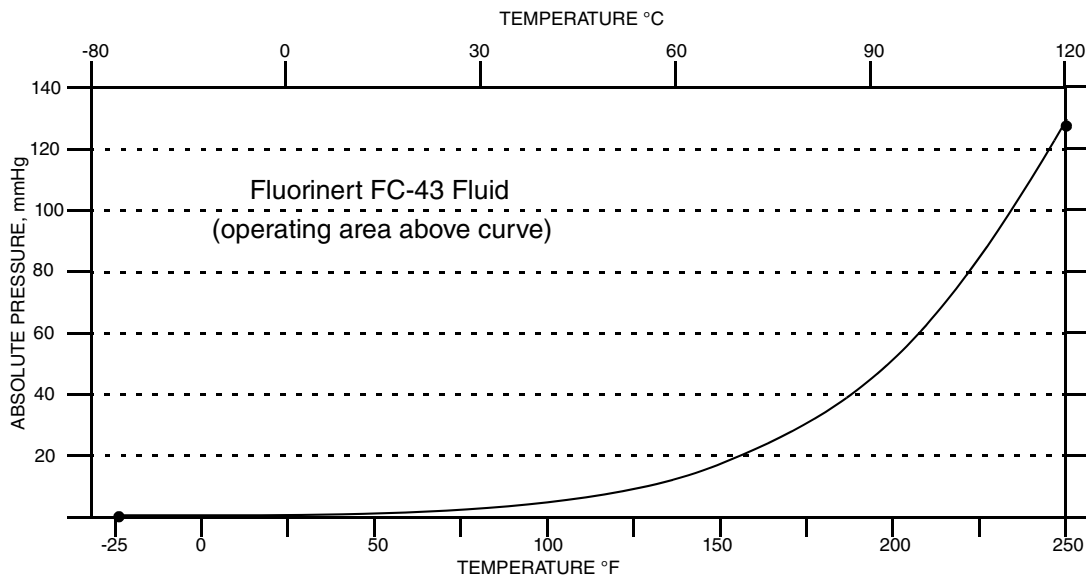

### Mounting Position

The transmitter can be mounted in any orientation. It can be directly mounted to the process with either the direct connected or pipe mounted designs. The housing can be rotated up to one full turn to any desired position for access to adjustments, display, or conduit connections. See “Positioning the Housing” on page 18. The display (if present) can also be rotated in the housing to any of four different positions at 90° increments. See “Positioning the Display” on page 19.

---

#### — NOTE —

Position effect zero shift for all calibrated spans can be eliminated by readjusting zero output after installation.

---

### Approximate Mass

IAP20, IGP20 (without process connector):	3.5 kg (7.8 lb)
IAP20 (with process connector):	3.8 kg (8.5 lb)
IGP20 (with process connector):	4.2 kg (9.2 lb)
With Optional 316 ss Housing:	Add 1.1 kg (2.4 lb)
With Pressure Seals:	Varies with seal used

### Process Connections

IAP20 and IGP20 transmitters are connected to the process via a 1/4 NPT thread or any one of a number of optional process connectors.

## Process Wetted Materials

Diaphragm:	Co-Ni-Cr, 316L ss, nickel alloy <sup>(1)</sup> , gold-plated 316L ss, Monel, or tantalum
Covers and Process Connectors:	316 ss, carbon steel, nickel alloy <sup>(1)</sup> , or Monel, or pvdf inserts
Pressure Seals:	Refer to MI 020-369
Sanitary Process Connections:	316L ss, nickel alloy <sup>(1)</sup>
Pulp and Paper Process Connections	316L ss, nickel alloy <sup>(1)</sup>

## Process Pressure and Temperature Limits for Pressure Seals

Refer to MI 020-369

## Electrical Connections

Field wires enter through 1/2 NPT, PG 13.5 or M20 threaded entrances on either side of the electronics housing. Leads terminate under screw terminals and washers on the terminal block in the field terminal compartment. To maintain RFI/EMI, environmental, and explosionproof ratings, unused conduit connection must be plugged with metal plug (provided), inserted to five full turns for 1/2 NPT connections; seven full turns for M20 and PG 13.5 connections.

## Adjustable Damping

The transmitter response time is normally 1.0 second or the electronically adjustable setting of 0.00 (none), 0.25, 0.50, 1, 2, 4, 8, 16, or 32 seconds, whichever is greater, for a 90% recovery from an 80% input step as defined in ANSI/ISA S51.1.

## Output Signal

FOUNDATION fieldbus linear.

## Zero and Span Adjustments

The zero and span is adjustable from the FOUNDATION fieldbus host computer or I/A Series console equipped with FOUNDATION fieldbus interface module. They are also adjustable at the transmitter using the display. An optional self-contained moisture sealed pushbutton assembly allows local resetting of the zero without removing the housing cover.

## Shielding (Screening)

For best performance, fieldbus cables should be shielded. Use common multi-conductor (multi-core) “instrument” cable with one or more twisted pairs, an overall, metallized shield, and a shield wire. You can also use cable that has individually shielded pairs. For new installations, ask cable vendors for “fieldbus cable.”

---

1. Equivalent to Hastelloy® C. Hastelloy is a registered trademark of Haynes International, Inc.

Connect the shield on each spur to the trunk shield and connect the overall shield to ground at **one point only**. For most networks, the grounding point can be located anywhere.

In some instances, better high-frequency EMI shielding requires that the shield be connected to ground at multiple points. (See Mardiguian, M., and White, D.R.J., EMI Control Methodology and Procedures.) FOUNDATION Fieldbus provides for this by allowing an rf ground at multiple points, consisting of a small capacitor from shield to ground.

## Supply Voltage

Power supply (a FOUNDATION fieldbus Power Supply Module) must be capable of providing at least 14 mA for each transmitter connected.

A summary of the voltage requirements is listed in Table 2.

*Table 2. Minimum Supply Voltage Requirements*

Minimum Supply Voltage	9 V
Recommended Supply Voltage	24 V
Maximum Supply Voltage	32 V

## Electrical Ground Connections

The transmitter is equipped with an internal ground connection within the field wiring compartment and an external ground connection at the base of the electronics housing. To minimize galvanic corrosion, place the wire lead or terminal between the captive washer and loose washer on the external ground screw. Earth (ground) the shield at one place per segment **only**. Refer to MI 020-360 for wiring guidelines.

## Remote Communications

Using the FOUNDATION fieldbus protocol, the transmitter communicates bidirectionally over the 2-wire field wiring to other FOUNDATION fieldbus devices (located anywhere in a Division 2 or nonhazardous area), or a FOUNDATION fieldbus host (anywhere in a nonhazardous area) and/or to an I/A Series system equipped with a FOUNDATION fieldbus interface module.

## Communications Format

Communication is based upon the FOUNDATION fieldbus communication protocol. The signals are superimposed on the transmitter power/signal leads.

## Digital Output

The transmitter can be configured to send its differential pressure measurement to the I/A Series system as a digital signal. Remote communications occur between the transmitter and other FOUNDATION fieldbus devices and hosts. The data transmission rate is 31.25 kbits/second. The maximum communication distance is 1900 m (6235 ft). This distance includes spur length. Maximum spur length is 120 m (395 ft). Minimum spur length is 1 m (3.3 ft). For intrinsically safe installations, maximum spur length is 30 m (98 ft).

# Product Safety Specifications

---

## — DANGER

To prevent possible explosions and to maintain flameproof, explosionproof, and dust-ignitionproof protection, observe applicable wiring practices. Plug unused conduit opening with the provided metal pipe plug. Both plug and conduit must engage a minimum of five full threads for 1/2 NPT connections; seven full threads for M20 and PG 13.5 connections.

---



---

## — WARNING

To maintain IEC IP66 and NEMA Type 4X protection, the unused conduit opening must be plugged with the metal plug provided. Use a suitable thread sealant on both conduit connections. In addition, the threaded housing covers must be installed. Turn covers to seat the O-ring into the housing and then continue to hand tighten until the cover contacts the housing metal-to-metal.

---



---

## — NOTE

1. These transmitters have been designed to meet the electrical safety description listed in Table 3. For detailed information or status of testing laboratory approvals/certifications, contact Invensys.
  2. Wiring restrictions required to maintain electrical certification of the transmitter are provided in “Wiring” on page 20.
- 

*Table 3. Electrical Safety Specifications*

Agency Certification, Types of Protection, and Area Classification	Application Conditions	Electrical Safety Design Code
ATEX flameproof: II 2 GD EEx d IIC, Zone 1.	KEMA 00ATEX2019X Temperature Class T6, T85°C Ta = -40 to +80°C.	D
ATEX FISCO field device intrinsically safe: II 1 G EEx ia IIC, Zone 0.	SIRA 04ATEX2335X Temperature Class T4, Ta = -40 to +80°C	E
ATEX FNICO field device protection n for: II 3 G EEx nL IIC, Zone 2.	SIRA 04ATEX4019X Temperature Class T4, Ta = -40 to +80°C.	N

**Table 3. Electrical Safety Specifications (Continued)**

Agency Certification, Types of Protection, and Area Classification	Application Conditions	Electrical Safety Design Code
<p>CSA FISCO field device intrinsically safe for Class I, Division 1, Groups A, B, C, and D; Class II, Division 1, Groups E, F, G; Class III Division 1.</p> <p>Also zone certified intrinsically safe Ex ia IIC, Zone 0 and energy limited Ex nA II, Zone 2.</p>	<p>Connect per MI 020-427. Temperature Class T6 at 40°C (104°F), and T4A at 85°C (185°F) maximum ambient.</p> <p>Temperature Class T4 at 40°C (104°F), and T3 at 85°C (185°F) max.ambient.</p>	C
<p>CSA explosionproof for Class I, Division 1, Groups B, C, and D; dust-ignitionproof for Class II, Division 1, Groups E, F, and G; Class III, Division 1.</p>	<p>Maximum Ambient Temperature 85°C (185°F).</p>	
<p>CSA FNICO field device for Class I, Division 2, Groups A, B, C, and D; Class II, Division 2, Groups F and G; Class III, Division 2.</p>	<p>Temperature Class T6 at 40°C (104°F) and T4A at 85°C (185°F) maximum ambient.</p>	
<p>CSA field device zone certified flameproof Ex d IIC. Also, all certifications of Code C above.</p>	<p>Maximum Ambient Temperature 85°C (185°F).</p>	B
<p>FM FISCO field device intrinsically safe for Class I, Division 1, Groups A, B, C, and D; Class II, Division 1, Groups E, F, G; Class III Division 1.</p> <p>Also zone certified intrinsically safe AEx ia IIC.</p>	<p>Connect per MI 020-427. Temperature Class T4A at 40°C (104°F) and T4 at 85°C (185°F) maximum ambient.</p> <p>Temperature Class T4 at 85°C (185°F) maximum ambient.</p>	F
<p>FM explosionproof for Class I, Division 1, Groups B, C, and D; dust-ignitionproof for Class II, Division 1, Groups E, F, and G; Class III, Division 1.</p>	<p>Temperature Class T6 at 80°C (176°F) and T5 at 85°C (185°F) maximum ambient.</p>	
<p>FM FNICO field device nonincendive for Class I, Division 2, Groups A, B, C, and D; Class II, Division 2, Groups F and G; Class III, Division 2.</p>	<p>Temperature Class T4A at 40°C (104°F) and T4 at 85°C (185°F) maximum ambient.</p>	
<p>FM field device zone certified flameproof AEx d IIC. Also, all certifications of Code F above.</p>	<p>Temperature Class T6 at 75°C (167°F) maximum ambient.</p>	G
<p>IECEX FISCO field device intrinsically safe: Ex ia IIC, Zone 0.</p>	<p>IECEX SIR 04.0036X Temperature Class T4, Ta = -40 to +80°C</p>	T
<p>IECEX FNICO field device protection n: Ex nL IIC, Zone 2.</p>	<p>IECEX SIR 04.0023X Temperature Class T4, Ta = -40 to +80°C</p>	U
<p>IECEX flameproof: Ex d IIC</p>	<p>IECEX FMG 06.0007X, Ex d IIC T6 Ta=80°C, T5 Ta=85°C Ambient Temperature -20 to +85°C</p>	V

## ATEX and IECEx Warnings

Do not open while circuits are alive.

## ATEX Compliance Documents

EN 50014: 1997

EN 50018: 1994

EN 50020: 2002

EN 50284: 1999

EN 60079-15: 2003

## IECEx Compliance Documents

IEC 60079-0 (Edition 4.0): 2004

IEC 60079-0 (Edition 3.1): 2000

IEC 60079-1 (Edition 5): 2003

IEC 60079-11 (Edition 4): 1999

IEC 60070-15 (Edition 2): 2001



## 2. Installation

---

**! CAUTION**

To avoid damage to the transmitter sensor, do not use any impact devices, such as an impact wrench or stamping device, on the transmitter.

---

**NOTE**

1. The transmitter should be mounted so that any moisture condensing or draining into the field wiring compartment can exit through one of the two threaded conduit connections.
  2. Use a suitable thread sealant on all connections.
- 

### Transmitter Mounting

The IAP20 and IGP20 transmitters must be mounted to a vertical or horizontal pipe or a surface using the mounting set. See Figures 4 and 5. For dimensional information, refer to DP 020-447.

---

**NOTE**

1. If the transmitter is not installed in the vertical position, readjust the zero output to eliminate the position zero effect. Be aware that an absolute pressure transmitter cannot be zeroed by venting the transmitter to atmosphere.
  2. The lower conduit port can be used as a drain for moisture buildup in terminal compartment.
- 

*Figure 4. Pipe Mounting*

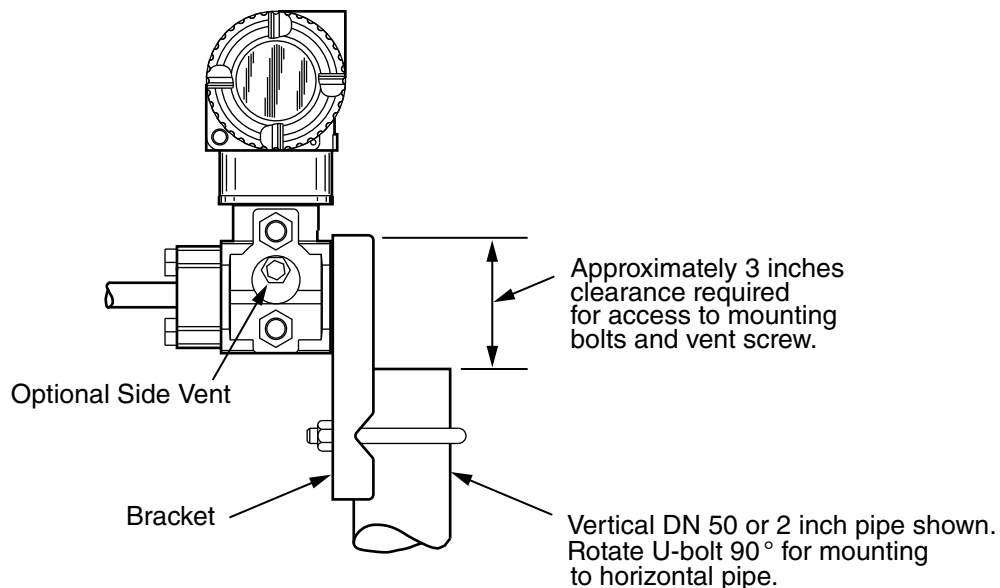

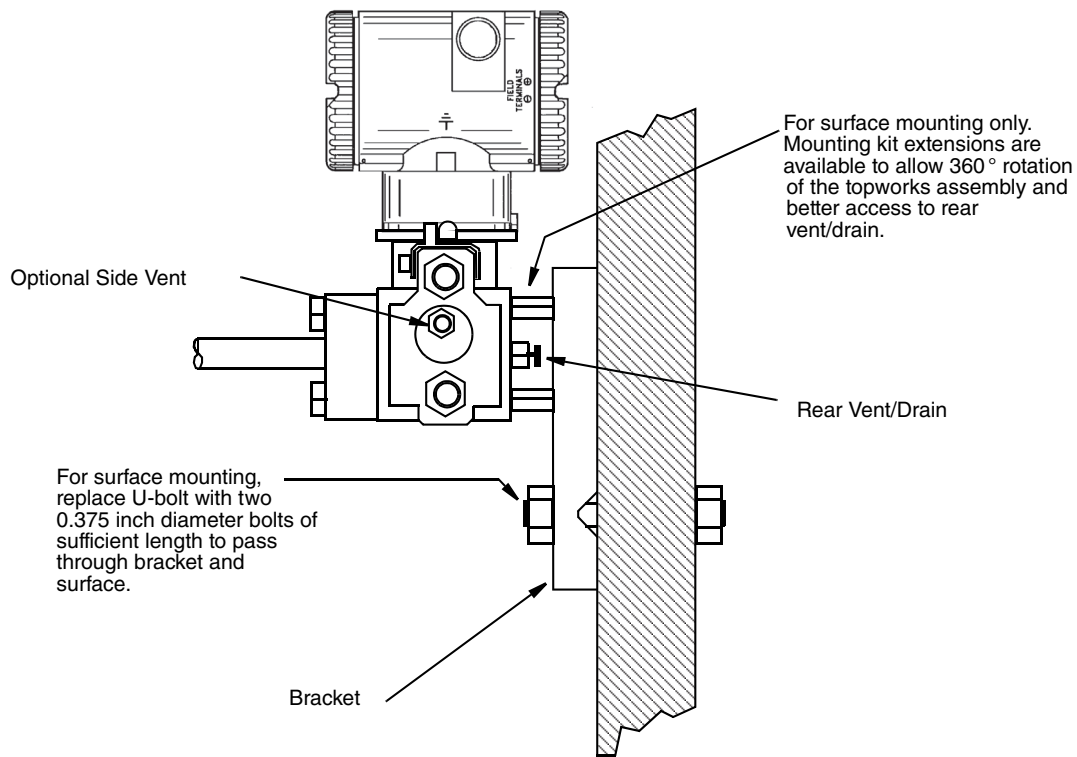
*Figure 5. Surface Mounting*

## Typical Transmitter Piping

The figure below shows a typical piping application. Tighten the process connector bolts to a torque of 61 N·m (45 lb·ft) and drain plugs and vent screws to a torque of 20 N·m (15 lb·ft).

---

### — NOTE —

1. Invensys recommends the use of snubbers in installations prone to high levels of fluid pulsations.
  2. When structure codes 78/79 (pvd insert) are used on an IAP20, the process connection must be made directly to the pvd insert in the high side process cover.
-

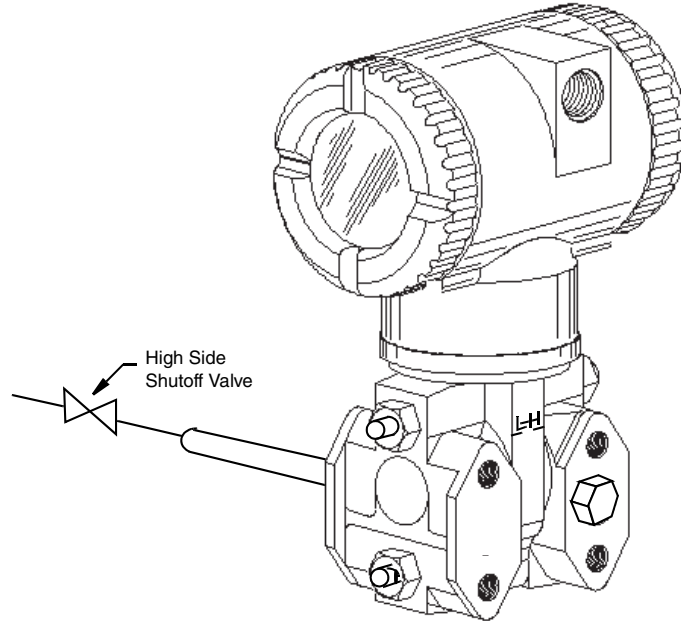
*Figure 6. Typical Transmitter Piping*

For hot process applications above the operative limits of your transmitter [121°C (250°F) for silicone fill fluid or 82°C (180°F) for fluorinert fill fluid], such as steam, additional piping is required to protect the transmitter from the hot process. See Figure 7. The piping is filled with water or process fluid. Mount the transmitter below the pressure connection at the pipe. Although the transmitter is shown mounted vertically, you can also mount it horizontally. The calibration tee is not required if a calibration screw is used for field calibrations.

If trapped vapor pockets cannot be tolerated in a liquid service and a horizontal process connection is used, install a pipe elbow and vertically position the transmitter with the housing **below** the process connection.

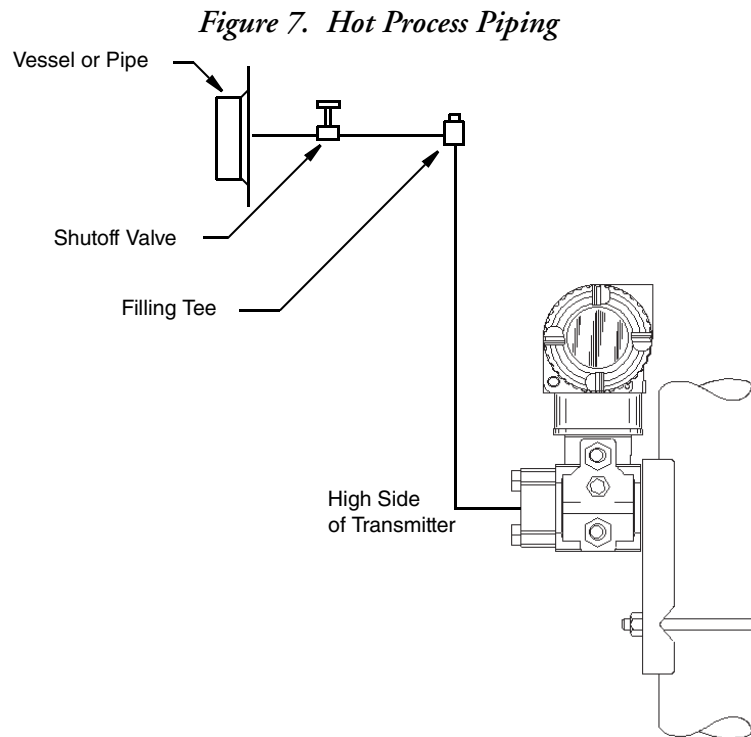

## Positioning the Housing

The transmitter housing (topworks) can be rotated up to one full turn in the counterclockwise direction when viewed from above for optimum access to adjustments, display, or conduit connections. Housings have either an anti-rotation screw or a retention clip that prevent the housing from being rotated beyond a safe depth of housing/sensor thread engagement.

### — **! WARNING** —

If the electronics housing is removed for maintenance, it must be hand tightened to the bottom of the threads, but not over-tightened upon reassembly. See “Removing and Reinstalling a Housing Assembly” on page 60.

**Figure 8. Housing Screw or Clip Location**

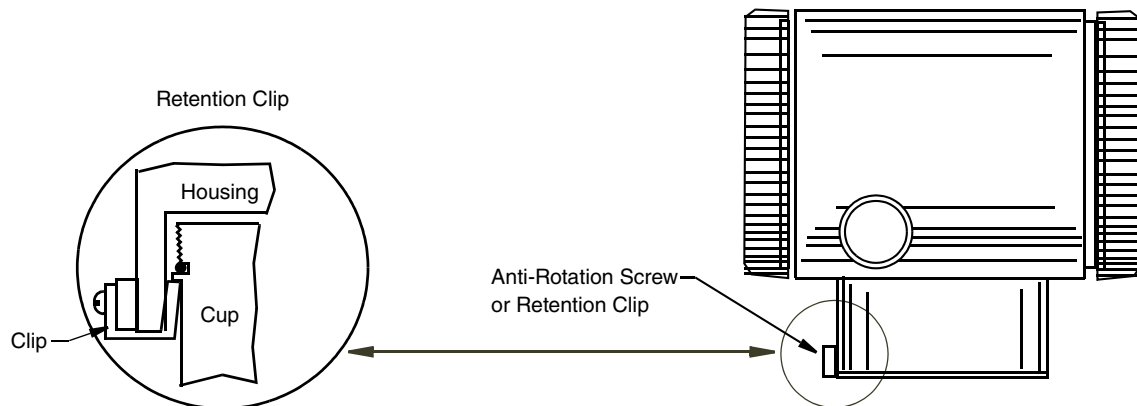

## Positioning the Display

The display (optional in some models) can be rotated within the housing to any of four positions at 90° increments. To do this, grasp the two tabs on the display and rotate it about 10° in a counterclockwise direction. Pull out the display. Ensure that the O-ring is fully seated in its groove in the display housing. Turn the display to the desired position, reinsert it in the electronics module, aligning the tabs on the sides of the assembly, and twist it in the clockwise direction.

---

### ! CAUTION

Do **not** turn the display more than 180° in any direction. Doing so could damage its connecting cable.

---

## Setting the Write Protect Jumper

Your transmitter has write protection capability. This means that the external zero, local display, and remote communications can be prevented from making changes to the static or nonvolatile data base in the function block application of the resource. Write protection can be set by moving a jumper that is located in the electronics compartment behind the optional display. To activate write protection, remove the display as described in the previous section, then remove the jumper or move it to the lower position. See Figure 9. Replace the display. When configuring the transmitter, select the **Hard W Lock** option in the **FEATURE\_SEL** parameter in the Resource Block. For more information on write protection in fieldbus devices, see MI 014-900.

*Figure 9. Write Protection Jumper*

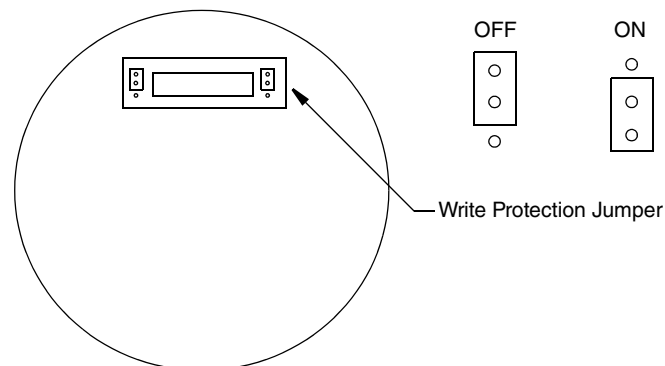

## Cover Locks

Electronic housing cover locks, shown in Figure 10, are provided as standard with certain agency certifications and as part of the Custody Transfer Lock and Seal option. To lock the covers, unscrew the locking pin until approximately 6 mm (0.25 in) shows, lining up the hole in the pin with the hole in the housing. Insert the seal wire through the two holes, slide the seal onto the wire ends and crimp the seal.

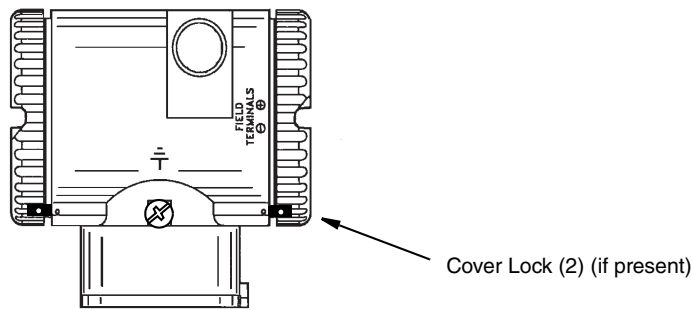
*Figure 10. Cover Lock Location*

## Wiring

The installation and wiring of your transmitter must conform to local code requirements.

---

### — **! WARNING** —

ATEX requires that when the equipment is intended to be used in an explosive atmosphere caused by the presence of combustible dust, cable entry devices and blanking elements shall provide a degree of ingress protection of at least IP6X. They shall be suitable for the conditions of use and correctly installed.

---

### — **NOTE** —

Invensys recommends the use of transient/surge protection in installations prone to high levels of electrical transients and surges.

---

## Accessing Transmitter Field Terminals

For access to the field terminals, thread the cover lock (if present) into the housing to clear the threaded cover and remove the cover from the field terminals compartment as shown in Figure 11. Note that the embossed letters **FIELD TERMINALS** identify the proper compartment.

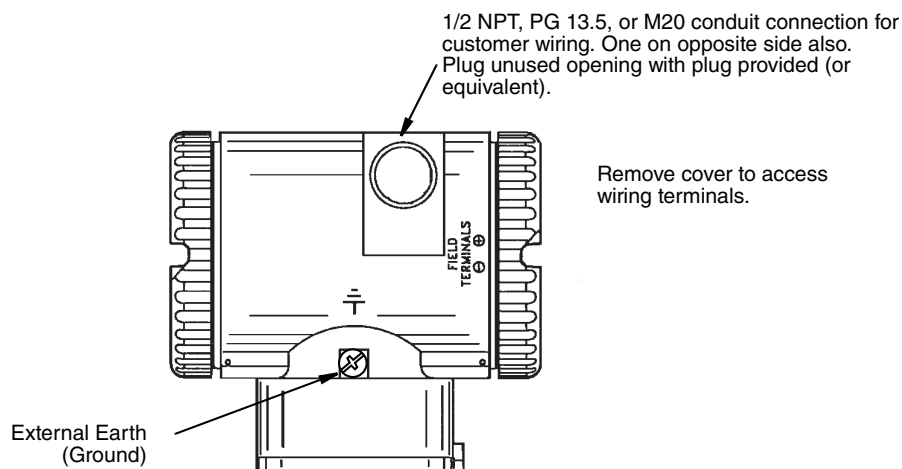
*Figure 11. Accessing Field Terminals*

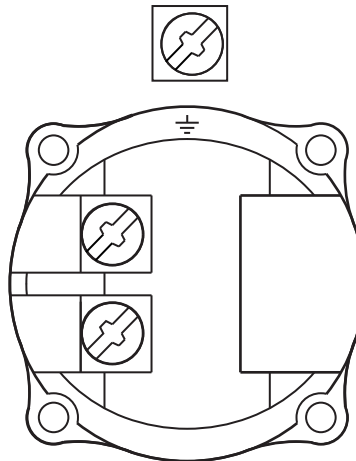
*Figure 12. Identification of Field Terminals*

## Wiring Notes

Do not run transmitter wires in the same conduit as mains (ac power) wires.

Use FOUNDATION fieldbus approved cable (multi-core, shielded, twisted-pair cable) to protect remote communications from electrical noise. Refer to MI 020-360 or FOUNDATION fieldbus Application Guide AG-140, Rev 1.0 or later.

The transmitter is polarity independent and therefore cannot be wired incorrectly.

Power supply (a FOUNDATION fieldbus Power Supply Module) must be capable of providing at least 14 mA for each transmitter connected.

A summary of the voltage requirements is listed in Table 4:

*Table 4. Minimum Supply Voltage Requirements*

Minimum Supply Voltage	9 V
Recommended Supply Voltage	24 V
Maximum Supply Voltage	32 V

Review suggested wiring practices as described in MI 020-360 to ensure proper communications capability and to minimize the effects of RFI.

Refer to Figure 13 for a wiring diagram of a typical transmitter installation.

**Figure 13. Wiring Diagram of Typical FOUNDATION Fieldbus Transmitter Installation**

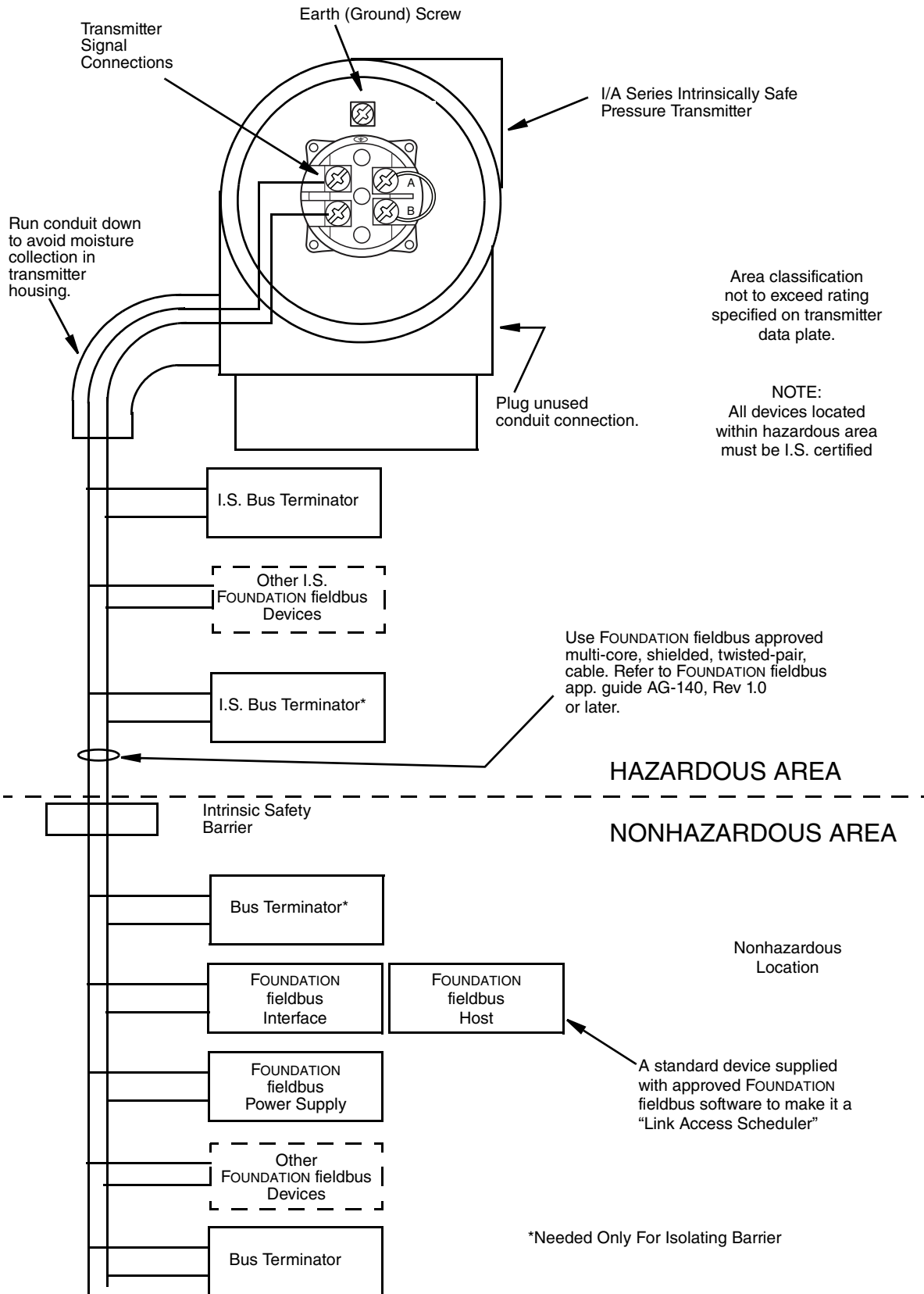

## Wiring the Transmitter

Transmitters with a digital output signal connect to a FOUNDATION fieldbus host or an I/A Series system through the fieldbus. Maximum recommended length for field wire is 1800 m (6000 ft). Transmitter power is supplied by a FOUNDATION fieldbus Power Supply Module. This procedure identifies wire terminations in the transmitter and in the I/A Series system enclosure. For other system wiring details, refer to the installation instructions provided with the I/A Series system.

Use the following procedure to wire the transmitter:

1. Remove the cover from the transmitter field terminal compartment.
2. Run signal wires (0.50 mm<sup>2</sup> or 18 AWG, typical) through one of the transmitter conduit connections. Use shielded twisted-pair cable to protect the digital output and/or remote communications from electrical noise.

---

— **NOTE** —

Do not run transmitter wires in same conduit as mains (ac power) wires.

---

3. Plug the unused conduit connection with the 1/2 NPT, PG 13.5, or M20 metal plug provided (or equivalent). To maintain specified explosionproof and dust-ignitionproof protection, the plug must engage a **minimum** of five full threads for 1/2 NPT connections; seven full threads for M20 and PG13.5 connections.
4. Connect an earth (ground) wire to the earth terminal in accordance with local practice.

---

—  **CAUTION** —

To avoid errors resulting from earth loops or the possibility of short-circuiting groups of instruments in a loop, use only one earth in a loop.

---

5. Connect the FOUNDATION fieldbus bus to the two terminals on the terminal block in the field terminal compartment.
6. Reinstall the cover onto the housing by rotating it clockwise to seat the O-ring into the housing and then continue to hand tighten until the cover contacts the housing metal-to-metal. If cover locks are present, lock the cover per the procedure described in “Cover Locks” on page 19.

# Installing the FOUNDATION Fieldbus Software

FOUNDATION fieldbus transmitters are shipped with a CD-ROM that contains specific device information and other files needed to configure the transmitters from a FOUNDATION fieldbus host. The files included on the CD-ROM are:

Filename	Description
<xxyy>.ffo <sup>(a)</sup>	DD binary file
<xxyy>.sym <sup>(a)</sup>	DD symbol file
<xxbbzz>.cff <sup>(a)(b)</sup>	Capability file

- a. xx = Device revision (Parameter 12 in Resource Block)  
yy = DD revision (Parameter 13 in Resource Block)
- b. 'bb' may be the same as 'yy' or may be 'ff'  
zz = cff rev

Set up the following directory structure for the DD files of a device on the host computer. According to the FOUNDATION specification, the device description files must be present in the appropriate directories as described below.

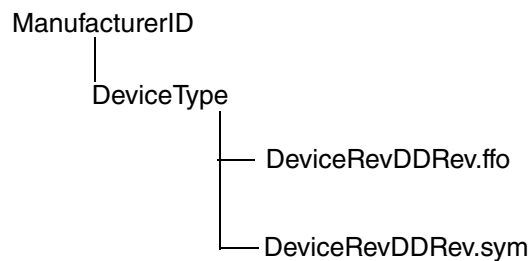

where \*.ffo is the DD binary file and \*.sym is the symbol file.

The Manufacturer ID for Invensys is 385884 and the Device Type for this pressure transmitter is BA30.

---

## — NOTE

1. The applicable DD and capability files are also available at [www.fieldbus.org](http://www.fieldbus.org).
  2. Foxboro parameter values are depicted in this document in the hex format.
-

# 3. Operation Via Local Display

A local display, as shown in Figure 14, has two lines of information. The upper line is a 5-digit numeric display (4-digit when a minus sign is needed); the lower line is a 7-digit alphanumeric display. The display provides local indication of measurement information. The primary (M1) measurement is normally displayed. To view the secondary (M2) measurement, press the **Enter** button while in normal operating mode. Press the **Next** or **Enter** button to return to the primary measurement. If left in M2 display, an M2 message blinks in the lower right of the display. If power to the transmitter is interrupted, the display reverts to the M1 display.

The display also provides a means for performing calibration and configuration, viewing the database, and testing the display via the 2-button keypad. You can access these operations by means of a multi-level menu system. Entry to the Mode Select menu is made (from normal operating mode) by pressing the **Next** button. You can exit this menu, restore your prior calibration or configuration, and return to the normal operating mode at any time by going to **Cancel** and pressing the **Enter** button.

The following items can be selected from this menu: Calibration (**CALIB**), Configuration (**CONFIG**), Viewing the database (**VIEW DB**), and Testing the display (**TST DSP**). The top level structure diagram is shown in Figure 15.

Figure 14. Local Display Module

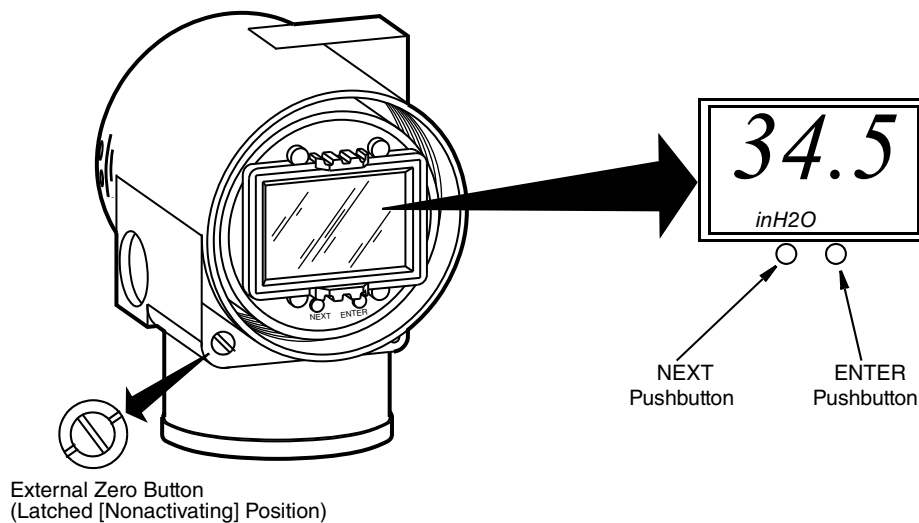
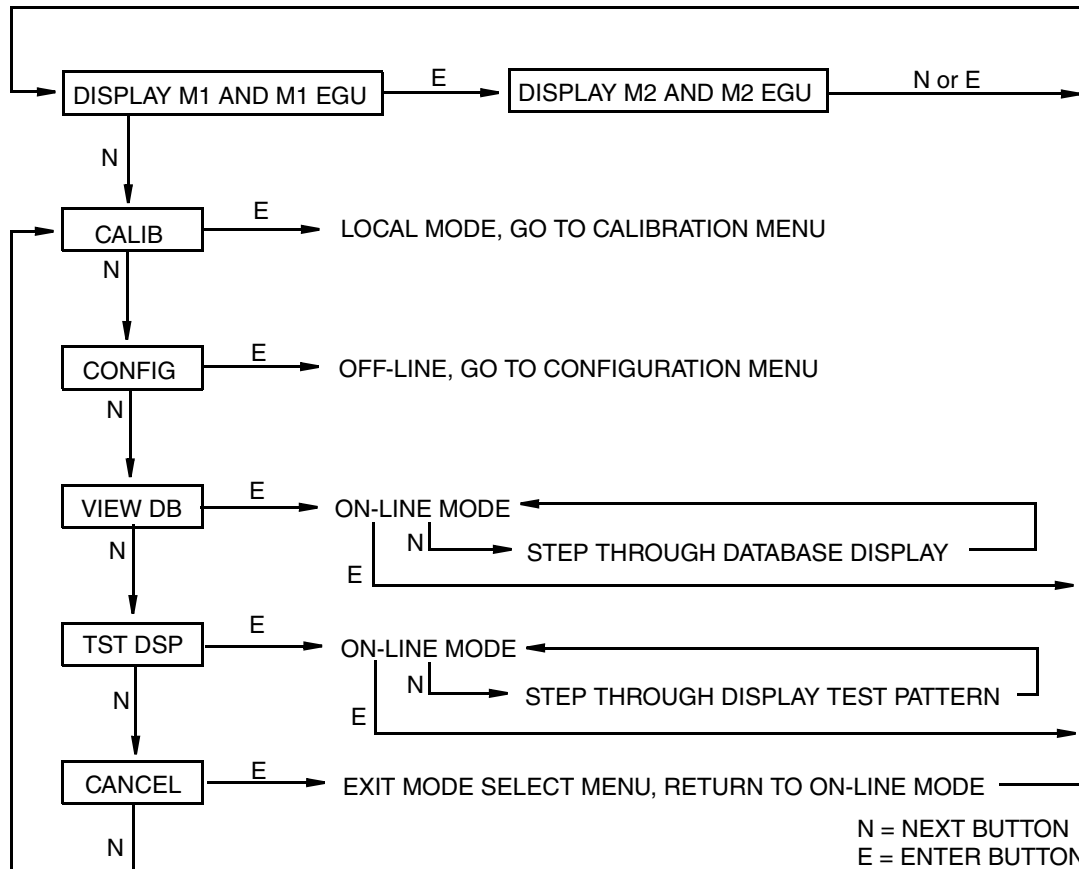

Figure 15. Top Level Structure Diagram



## Entering Numerical Values

The general procedure for entering numerical values in Calibration and Configuration is as follows:

1. At the appropriate prompt, press the **Enter** button. The display shows the last (or default) value with the first digit flashing.
2. Use the **Next** button to select the desired first digit, then press the **Enter** button. Your selection is entered and the second digit flashes.
3. Repeat Step 2 until you have created your new value. If the number has less than five characters, use leading or trailing zeros for the remaining spaces. When you have configured the fifth space, the display prompts you to place the decimal point.
4. Move the decimal point with the **Next** button until it is where you want it and press the **Enter** button.

---

### — NOTE —

1. The decimal point may not be placed directly after the first digit. For example, you can not enter a value as 1.2300; you must enter it as 01.230.
  2. The decimal position is identified by flashing except at the position after the fifth digit. At that position (representing a whole number), the decimal point is assumed.
- 

5. The display advances to the next menu item.

## Viewing the Database

You can access the View Database mode by the multi-level menu system described above. Entry to the Mode Select menu is made (from normal operating mode) by pressing the **Next** button. The display reads **CALIB**, the first item on the menu. Press the **Next** button twice to get to the third item on the menu, **VIEW DB**. Acknowledge your choice of this selection by pressing the **Enter** button. The display shows the first item in the database. You can step through the database display by repeated use of the **Next** button. You can abort this procedure at any time by pressing the **Enter** button.

## Viewing the Pressure Range

The values of **M1\_LRV** and **M1\_URV** can be viewed in **VIEW DB** as described above. They can also be viewed in the **RERANGE** function in Calibration mode and Configuration mode.

## Testing the Display

You can access the Test Display mode by the same multi-level menu system that was used to enter Calibration, Configuration, and View Database mode. Entry to the Mode Select menu is made (from normal operating mode) by pressing the **Next** button. The display reads **CALIB**, the first item on the menu. Press the **Next** button three times to get to the fourth item on the menu, **TST DSP**. Acknowledge your choice of this selection by pressing the **Enter** button. The display shows the first test segment pattern. You can step through the five patterns by repeated use of the **Next** button. You can abort the test at any time by pressing the **Enter** button. The five patterns are shown in Figure 16.

Figure 16. Display Test Segment Patterns

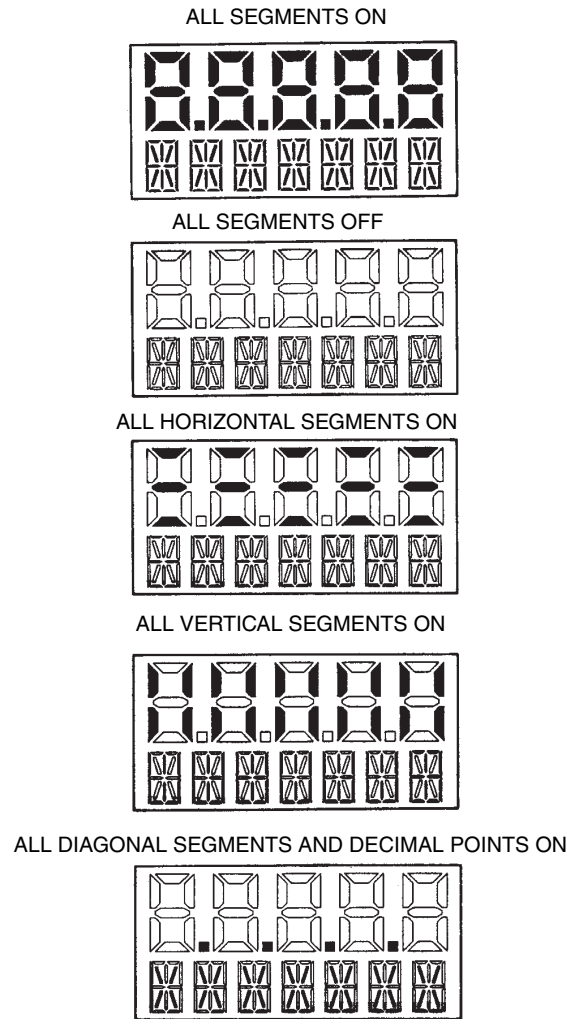

# 4. Calibration

---

— **NOTE** —

1. For best results in applications where high accuracy is required, rezero the transmitter output once it has stabilized at the final operating temperature.
  2. Zero shifts resulting from position effects and/or static pressure effects can be eliminated by rezeroing the transmitter output.
- 

## Calibration Setup

The following sections show setups for field or bench calibration. Use test equipment that is at least three times as accurate as the desired accuracy of the transmitter.

---

— **NOTE** —

It is not necessary to set up calibration equipment to rerange the transmitter to a different range. The transmitter can be accurately reranged by simply changing the lower range value and the upper range value, which are stored in the transmitter database.

---

## Field Calibration Setup

Field calibration is performed without disconnecting the process piping. This is only possible if you have a shutoff valve between the process and the transmitter and the process covers vent screw option (-V1).

If the transmitter is to be removed from the process for calibration, refer to “Bench Calibration Setup” below.

An adjustable air supply and a pressure measuring device are required. For example, a dead weight tester or an adjustable clean air supply and pressure gauge can be used. The pressure source can be connected to the transmitter with pipe fittings or it can be connected to the vent screw assembly using a calibration screw. The calibration screw has a Polyflo fitting and can be used for pressures up to 700 kPa (100 psi). It is available as Invensys Part Number F0101ES.

To set up the equipment, refer to the figure below and then use the following procedure:

1. Close the shutoff valve between the process and the transmitter.
2. If a calibration screw **is** being used, remove the vent screw and replace it with the calibration screw. Connect the pressure source to the calibration screw using 6 x 1 mm or 0.250 inch tubing.  
If a calibration screw **is not** being used, remove the drain plug or the entire vent screw assembly (as applicable) from the high pressure side of the transmitter. Connect calibration tubing using a suitable thread sealant.
3. If calibrating the output signal, also connect equipment as shown in "Setup of Electronic Equipment."

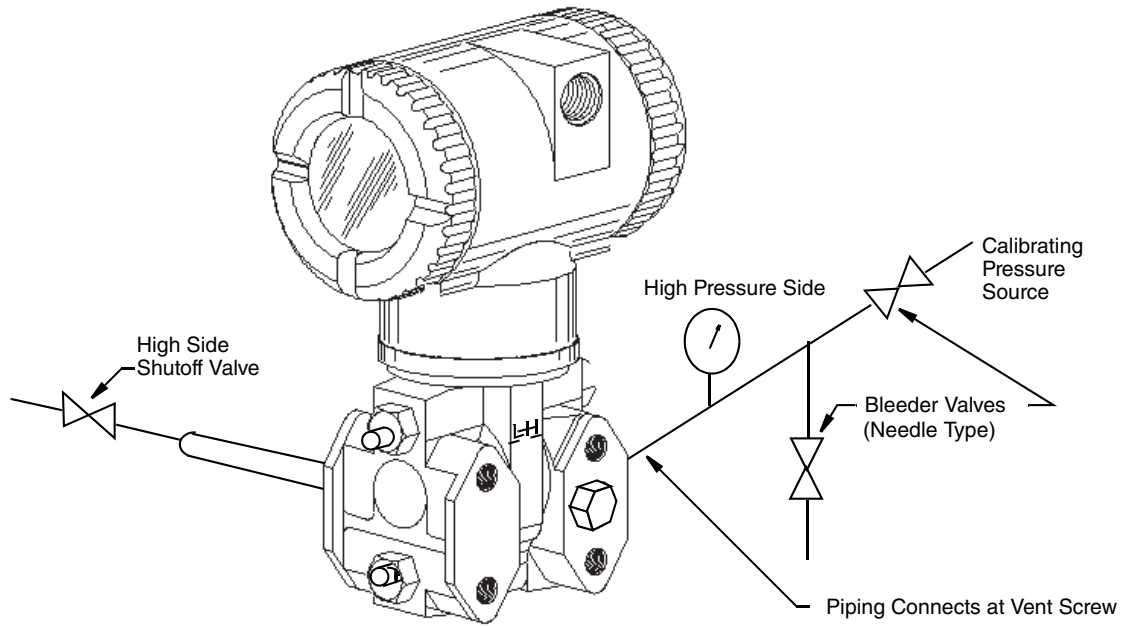
*Figure 17. IAP20 and IGP20 Field Calibration Setup*

## Bench Calibration Setup

The bench calibration setup requires disconnecting the process piping. For calibration setup without disconnecting the process piping, refer to “Field Calibration Setup” above.

The bench calibration setup is shown in Figure 18. Connect the input piping to the high pressure side of the transmitter as shown. Vent the low pressure side of the transmitter.

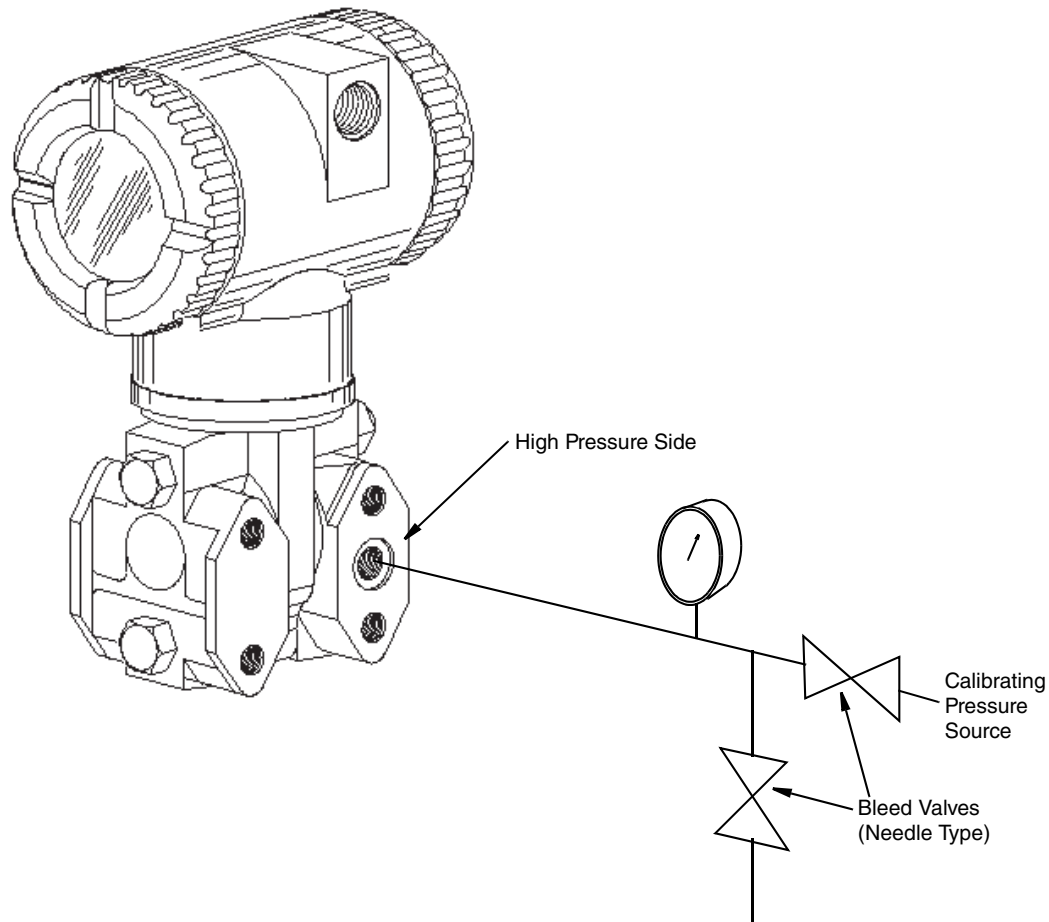
*Figure 18. Bench Calibration Setup*

## Calibration Using the Optional Local Display

From the display, you can:

- ◆ Zero the transmitter at zero pressure
- ◆ Calibrate the lower range value (LRV or 0% range value)
- ◆ Calibrate the upper range value (URV or 100% range value)
- ◆ Rerange your transmitter by adjusting the 0% and 100% range values.

---

### NOTE

1. 4 to 20 mA calibration is not available with FOUNDATION fieldbus transmitters.
  2. If calibration has been configured as password protected, you are asked to enter the password before you can proceed.
  3. If your transmitter is write protected, you cannot write your calibration to the electronics without disabling this feature.
- 

To access the Calibration mode (from normal operating mode), press the **Next** button. The display reads **CALIB**, the first item on the menu. Acknowledge your choice of this selection by pressing the **Enter** button. The display shows the first item in the Calibration menu shown in Figure 19.

Proceed to calibrate your transmitter by using the **Next** button to select your item and the **Enter** button to specify your selection per Figure 19. At any point in the calibration you can **Cancel**, restore your prior calibration and return to the on-line mode or **Save** your new calibration.

**— NOTE**

Before doing a CAL AT0, CAL LRV, or CAL URV calibration, check your M1\_LRV and M1\_URV values to make sure that they are the proper 0% and 100% range values for your application. If not, use the Next button to go to RERANGE to set the proper M1\_URV and M1\_LRV. Save these changes.

Figure 19. Calibration Structure Diagram

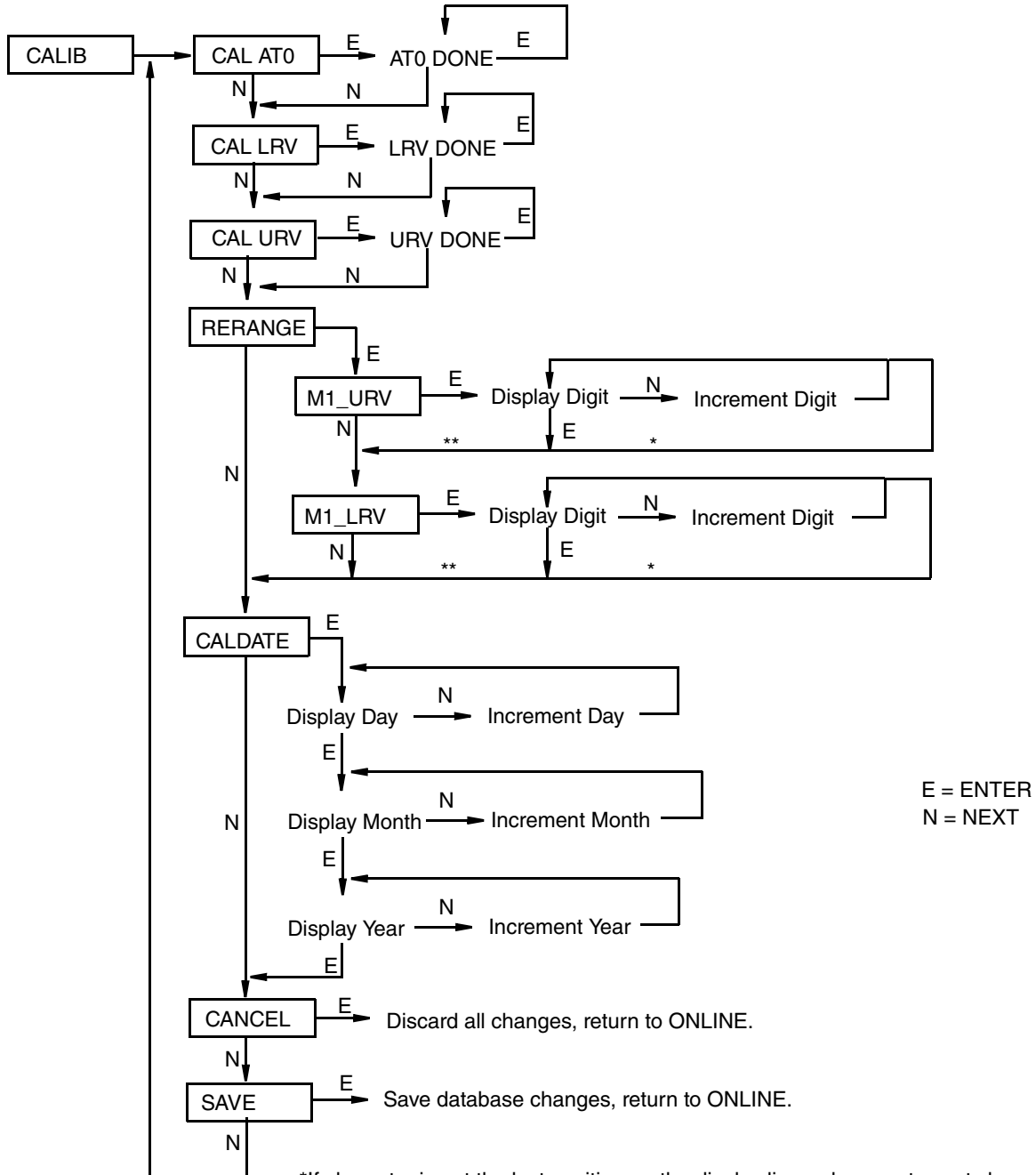

\*If character is not the last position on the display line, advances to next character.  
 \*\*If character is the last position on the display line, advances to next menu item.

**CAL AT0:**

To zero the transmitter at zero pressure, apply a zero pressure to the transmitter. Go to CAL AT0 using the **Next** button and press **Enter**. This can be done whether the LRV is zero or not. Completion is indicated by the display AT0 Done.

**— NOTE**

---

This function cannot be done from a fieldbus host.

---

**CAL LRV:**

To calibrate at 0% of range input, apply a pressure to the transmitter equal to the lower range value (M1\_LRV) in the transmitter database. Go to CAL LRV using the **Next** button and press **Enter**. Completion is indicated by the display LRV Done.

**CAL URV:**

To calibrate at 100% of range input, apply a pressure to the transmitter equal to the upper range value (M1\_URV) in the transmitter database. Go to CAL URV using the **Next** button and press **Enter**. Completion is indicated by the display URV Done.

**RERANGE:**

To adjust 100% and 0% range values without application pressure, go to RERANGE using the **Next** button and press **Enter**. You can then adjust M1\_URV and/or M1\_LRV in the following two submenus.

**M1\_URV:**

To edit the upper range value, press **Enter** at the prompt M1\_URV. Use the procedure “Entering Numerical Values” in Operation section to edit this parameter.

**M1\_LRV:**

To edit the lower range value, press **Enter** at the prompt M1\_LRV. Use the procedure “Entering Numerical Values” in Operation section to edit this parameter.

**CALDATE:**

This is not a required entry but can be used for recordkeeping or plant maintenance purposes. To edit the calibration date, go to CALDATE with the **Next** button and press **Enter**. You then can change the day, month, and year. The display shows the last date with the day flashing. Use the **Next** button to step through the menu of digits to select the desired day, then press **Enter**. Repeat this process for the month and year.

## Zero Adjustment Using External Zero Button

An external zero adjustment mechanism in the electronics housing allows calibration at zero differential pressure (the CAL AT0 function) or at the lower range value differential pressure (the CAL LRV function) without removing the electronics compartment cover. The mechanism is magnetically activated through the housing wall to prevent moisture from entering the enclosure.

To use this feature:

1. Unlatch the external zero button by turning it 90° in a counterclockwise direction so that the screwdriver slot lines up with the two holes in the face of the adjacent part. Do **not** push the button in with the screwdriver while doing this.
2. To set or reset the zero point at zero pressure, apply zero pressure to the transmitter and press the external zero button until the display reads CAL AT0. Release the button. The display reads CAL WAIT and then RESET (calibration is complete).

To set or reset the 0% of range input, apply the lower range value (LRV) pressure to the transmitter and press and hold the external zero button until the display reads CAL LRV (it reads CAL AT0 first). Release the button. The display reads CAL WAIT and then RESET (calibration is complete).

---

### — NOTE —

If the optional display is not present, the same functions can be accomplished by depending on the length of time the external zero button is depressed. Press and hold the button for 1 to 3 seconds for CAL AT0 or for 5 or more seconds for CAL LRV. Therefore, if your LRV is zero, just depress the button for a few seconds. However, if your LRV is not zero, use **caution** when using the external zero button without the optional display because you must rely strictly on the length of time the button is depressed to differentiate between CAL AT0 and CAL LRV.

---

3. Another possible message is DISABLD if EX ZERO is configured EXZ DIS. NA/AP is displayed if CAL AT0 is performed on an Absolute Pressure Transmitter (IAP20).
4. If additional rezeroing is required after Steps 1 and 2 have been accomplished, repeat Step 2.
5. Relatch the external zero button by turning it 90° in a clockwise direction to prevent accidental pressing of the button. Do **not** push the button in with the screwdriver while doing this.

## Calibration from a FOUNDATION Fieldbus Host

---

### — NOTE —

Before doing a calibration, check your PRIMARY\_VALUE\_RANGE • EU\_at\_100% and EU\_at\_0% values to make sure that they are the proper values for your application. If not, adjust these values as necessary. Refer to “Changing the Primary Range Values (Reranging) by Editing the Transducer Block Parameters” on page 51.

---

1. Put the Transducer Block in the Out Of Service (OOS) mode and make sure the MODE\_BLK • ACTUAL reads OOS.

---

**— NOTE**

It is important that you perform Steps 2 and 3 before Steps 4 and 5.

---

2. Apply the lower range value pressure to the transmitter.
3. Enter the value of the pressure applied to the transmitter into the CAL\_POINT\_LO parameter. Write the change to the transmitter.
4. Apply the upper range value pressure to the transmitter.
5. Enter the value of the pressure applied to the transmitter into the CAL\_POINT\_HI parameter. Write the change to the transmitter.

---

**— NOTE**

The difference between the lower range and upper range pressures must equal or exceed the CAL\_MIN\_SPAN.

---

6. Select the method from the SENSOR\_CAL\_METHOD parameter (normally set for User Trim Standard Calibration).
7. Type in the location in the SENSOR\_CAL\_LOC parameter.
8. Type in the initials of the person performing the calibration in the SENSOR\_CAL\_WHO parameter.
9. Adjust the SENSOR\_CAL\_DATE parameter.
10. Write the changes to the transmitter.
11. Put the Transducer Block in the Auto mode and make sure the MODE\_BLK • ACTUAL reads Auto.



# 5. Configuration

## Configuration Using the Optional Local Display

The transmitter can be configured from the optional local display or from a FOUNDATION fieldbus host. Some of the parameters can be configured from either the display and the host; others can be configured only from the display or the host.

Table 5 lists all parameters that can be configured from the optional local display, the parameter values or options selected by the factory when the transmitter is shipped, and a list of comments and/or procedures to be followed when configuring the transmitter from a fieldbus host.

*Table 5. Parameters Configurable from the Local Display*

Parameter	Available Choices when Configuring from the Local Display	Local Display Initial Factory Settings	Procedure when Configuring from a FOUNDATION fieldbus Host
IT MODE	Digital only	Digital	N/A
DEVNAME	(up to six characters)	DevNam	N/A
EX ZERO	Enable (EXZ ENA) or disable (EXZ DIS)	Disable	N/A
DAMPING	0, 0.25, 0.5, 1, 2, 4, 8, 16, or 32 seconds	None (NO DAMP)	Edit Transducer Block SENSOR_DAMPING parameter
M1 MODE	Linear Only	Linear	N/A
M1 DISP	M1 EGU or LIN PCT <sup>(a)</sup>	M1 EGU	N/A (The M1 DISP setting only affects the value shown on the optional local display module. It does not affect the values transmitted to the FOUNDATION fieldbus host.)
M1_EGU	User-selected pressure engineering units	(Per Sales Order)	Edit Transducer Block PRIMARY_VALUE_RANGE • UNITS_INDEX parameter
M1_LRV <sup>(b)</sup>	User configurable value	---	Edit Transducer Block PRIMARY_VALUE_RANGE • EU_0 parameter
M1_URV	User configurable value	---	Edit Transducer Block PRIMARY_VALUE_RANGE • EU_100 parameter
M2 MODE <sup>(c)</sup>	Linear	Linear	Edit Transducer Block THIRD_VALUE_TYPE

Table 5. Parameters Configurable from the Local Display (Continued)

Parameter	Available Choices when Configuring from the Local Display	Local Display Initial Factory Settings	Procedure when Configuring from a FOUNDATION fieldbus Host
M2 DISP <sup>(d)</sup>	If M2 Mode is linear, M2 DISP can only be set to =M2_EGU (pressure units).  If you see flow units in the M2 DISP menu, make sure M2 MODE is set to M2 LIN (linear). Square root modes are not valid for absolute or gauge pressure measurement.	=M2_EGU	N/A (The M2 DISP setting only affects the value shown on the optional local display module. It does not affect the values transmitted to the FOUNDATION fieldbus host.)
M2_EGU	User-defined engineering units	Same as M1_EGU	Edit Transducer Block THIRD_VALUE_RANGE • UNITS_INDEX parameter
DISPLAY <sup>(d)</sup>	Show M1, Show M2, or Toggle	Show M1	N/A
CALDATE	Calibration Date	- - -	Edit Transducer Block SENSOR_CAL_DATE parameter
ENA_PWD	No Passwords, Configuration, or Config and Calibration	No Passwords	N/A

- a. The M1 DISP menu selections are limited for specific firmware versions. M1 DISP cannot be set to LIN PCT with firmware versions 4.04 and earlier or with firmware version 5.00.
- b. M1\_LRV is only available if M2 MODE is linear.
- c. Make sure M2 MODE is linear (M2 LIN). Setting M2 MODE to a type of square root is not valid for IAP20-F and IGP20-F transmitters.
- d. The M2 DISP and DISPLAY menus are not available with firmware versions 4.04 and earlier or with firmware version 5.00.

—  **CAUTION** —

In the diagrams, a shaded outline box indicates a menu selection that is **not** valid for IAP20-F and IGP20-F transmitters. Therefore, you are cautioned **not** to configure such items.

Figure 20. Configuration Structure Diagram (1 of 3)

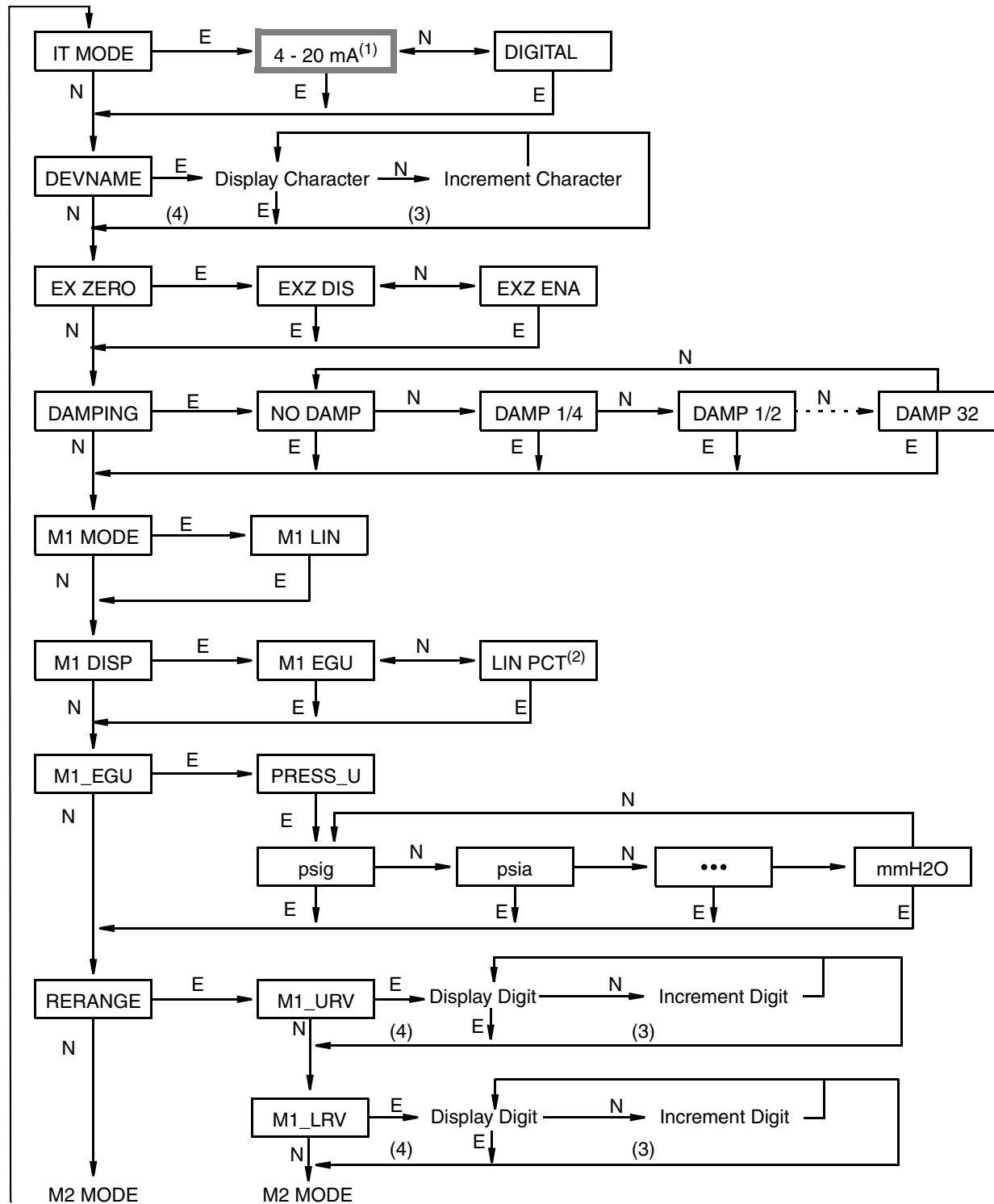

NOTES:

1. 4-20 mA is not a valid menu selection for FOUNDATION fieldbus transmitters.
2. LIN PCT provides percent output on LCD indicator only, and is not available with firmware versions 4.04 and earlier or with firmware version 5.00.
3. If character is not the last position on the display line, advances to next character.
4. If character is the last position on the display line, advances to next menu item.

Figure 21. Configuration Structure Diagram (2 of 3)

(continued from previous page)

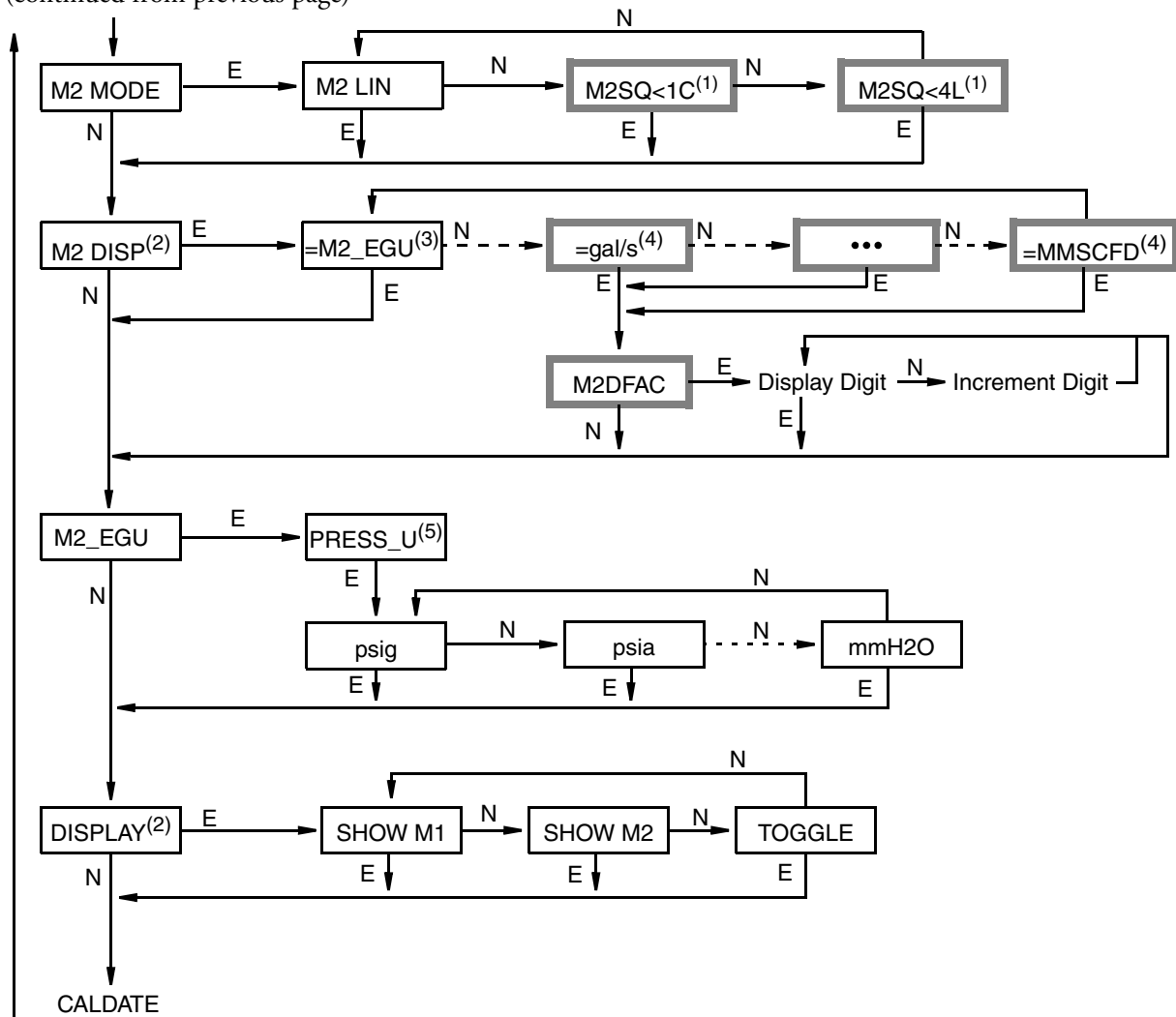

NOTES:

1. M2SQ<1C and M2SQ<4L are not valid for absolute or gauge pressure measurement.
2. The M2 DISP and DISPLAY menus are not available with firmware versions 4.04 and earlier or with firmware version 5.00
3. When M2 MODE is linear (M2 LIN), =M2\_EGU is the only available selection in the M2 DISP menu.  
M2 will appear on the local display with pressure engineering units selected in M2\_EGU.
4. Flow units are not valid for absolute or gauge pressure measurement. Make sure M2 MODE is linear (M2 LIN).
5. If INVALID flashes on the local display after selecting PRESS\_U, make sure M2 MODE is linear (M2 LIN).

Figure 22. Configuration Structure Diagram (3 of 3)

(continued from previous page)

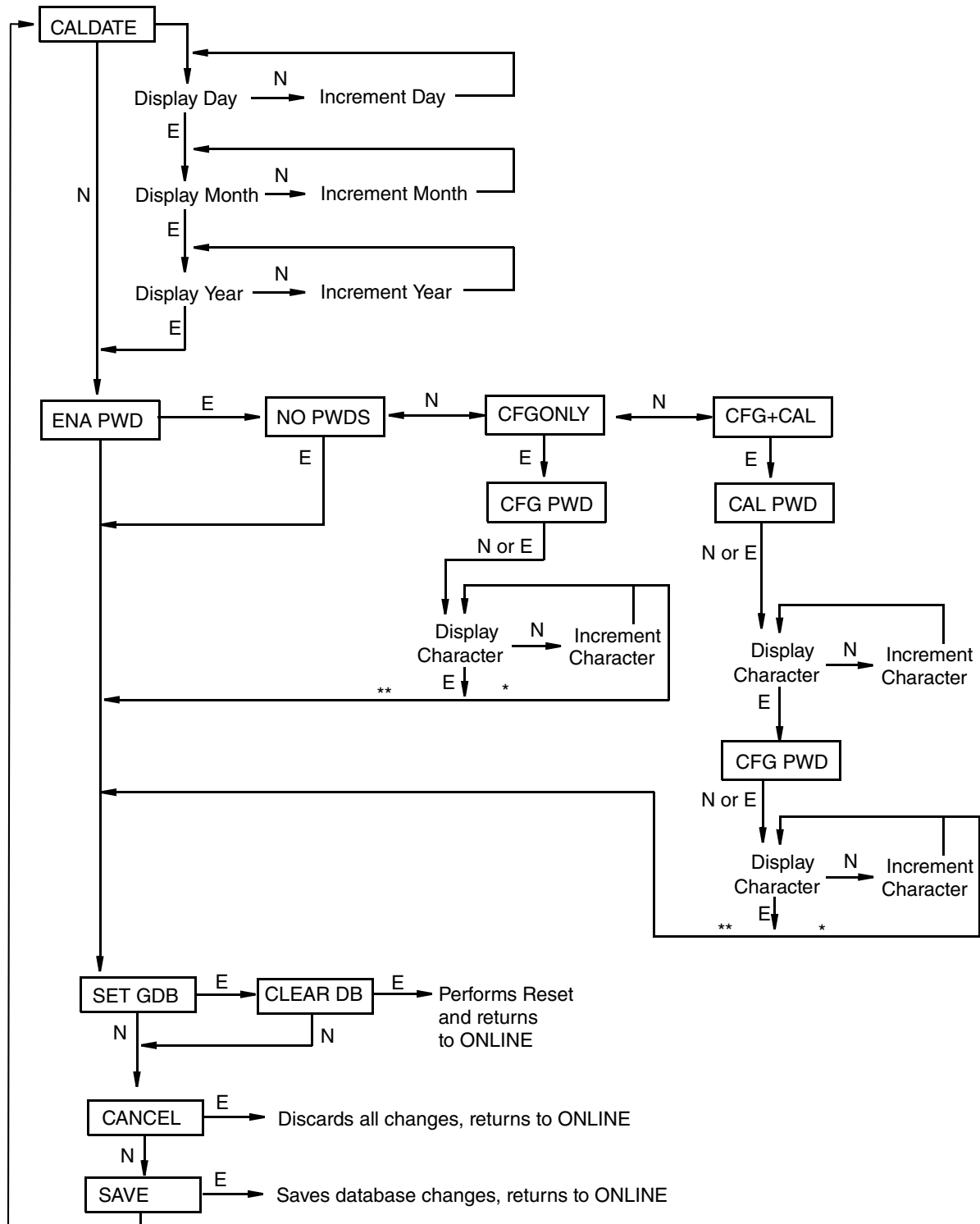

\* If character is not the last position on the display line, advances to next character.  
 \*\* If character is the last position on the display line, advances to next menu item.

## Commentary on Configuration Structure Diagrams

In general, use the **Next** button to select your item and the **Enter** button to specify your selection.

### IT MODE:

To configure the transmitter operating mode, press **Enter**. Use the **Next** button to select **DIGITAL** and press **Enter**. The **4 - 20 mA** selection is not valid for a **FOUNDATION** fieldbus transmitter.

### DEVNAME:

This parameter is not applicable for a **FOUNDATION** fieldbus transmitter.

### EX ZERO:

The External Zero feature allows the optional external zero pushbutton to be disabled for additional security. To configure this feature, go to **EX ZERO** with the **Next** button and press **Enter**. Use the **Next** button to select **EXZ DIS** or **EXZ ENA** and press **Enter**.

### DAMPING:

To configure additional damping, go to **DAMPING** with the **Next** button and press **Enter**. Use the **NEXT** button to select **NO DAMP**, **DAMP 1/4**, **DAMP 1/2**, **DAMP 1**, **DAMP 2**, **DAMP 4**, **DAMP 8**, **DAMP 16**, or **DAMP 32** and press **Enter**.

### M1 MODE:

To configure the mode of the primary output, go to **M1 MODE** with the **Next** button and press **Enter**. Use the **Next** button to select **M1 LIN** (linear) and press **Enter**.

### M1 DISP:

To configure the display to show **M1** in engineering units or percent pressure, go to **M1 DISP** with the **Next** button and press **Enter**. Use the **Next** button to select **M1 EGU** or **LIN PCT** and press **Enter**.

---

#### — NOTE —

**LIN PCT** is not available with firmware versions 4.04 and earlier or with firmware version 5.00.

---

Selecting **LIN PCT** causes percent readings to appear with a **% lin** label on the local display only. The **M1** pressure engineering unit is used for remote communication of Measurement #1, even if **LIN PCT** is selected.

**M1\_EGU:**

To configure engineering units for your display and transmission, go to M1\_EGU with the Next button and press Enter. Use the Next button to select PRESS\_U and press Enter.

You are then asked to specify one of the following labels: psig, psia, inHg, ftH<sub>2</sub>O, inH<sub>2</sub>O, atm, bar, mbar, MPa, kPa, Pa, kg/cm<sup>2</sup>, g/cm<sup>2</sup>, dy/cm<sup>2</sup>, cmHg, mmHg, torr, cmH<sub>2</sub>O, or mmH<sub>2</sub>O.

**RERANGE:**

To adjust 100% and 0% range values without application pressure, go to RERANGE with the Next button and press Enter. You can then adjust M1\_URV and/or M1\_LRV in the following two submenus.

**M1\_URV:**

To edit the upper range value, press Enter at the prompt M1\_URV. Use the procedure in “Entering Numerical Values” on page 30 to edit this parameter.

**M1\_LRV:**

To edit the lower range value, press Enter at the prompt M1\_LRV. Use the procedure in “Entering Numerical Values” on page 30 to edit this parameter.

**— NOTE**

---

M1\_LRV is only available when M2 MODE is linear.

---

**M2 MODE:**

M2 is a secondary measurement that is read by the I/A Series system and can be displayed on the optional display. You might use this feature to display M1 in primary pressure units and M2 in other pressure units.

To configure this parameter, go to M2 MODE with the Next button and press Enter. Use the Next button to select M2 LIN (linear) and press Enter.

**— NOTE**

---

Although they appear in the menu, the M1SQ<1C and M1SQ<4L selections are not valid for absolute or gauge pressure measurement.

---

## M2 DISP

When M2 MODE is linear (M2 LIN), M2 DISP allows you to show the M2 reading in pressure engineering units on the local display. This menu is not available with firmware versions 4.04 and earlier or with firmware version 5.00.

M2 DISP should be set to =M2\_EGU for absolute and gauge pressure transmitters. =M2\_EGU is the only menu selection for a linear M2 MODE.

---

### — NOTE

If any flow units appear in this menu, M2 MODE is likely incorrectly set to a square root function, which is not valid for absolute or gauge pressure measurement. Make sure that M2 MODE is set to M2 LIN (linear).

---

## M2\_EGU:

To configure the engineering units in which M2 will appear on the local display, go to M2\_EGU with the Next button and press Enter. Use the Next button to select PRESS\_U and press Enter.

You are then asked to specify one of the following labels: psig, psia, inHg, ftH<sub>2</sub>O, inH<sub>2</sub>O, atm, bar, mbar, MPa, kPa, Pa, kg/cm<sup>2</sup>, g/cm<sup>2</sup>, dy/cm<sup>2</sup>, cmHg, mmHg, torr, cmH<sub>2</sub>O, or mmH<sub>2</sub>O.

---

### — NOTE

If you configured M2 MODE in a square root mode (M1SQ<1C or M1SQ<4L), INVALID temporarily appears on the local display if you press Enter at this menu selection. Because the square root modes are not valid for absolute or gauge pressure measurement, be sure that M2 MODE is set to M2 LIN (linear).

---

## DISPLAY:

This parameter allows you to configure whether the optional local indicator display shows M1, M2, or toggles between M1 and M2. This menu is not available with firmware versions 4.04 and earlier or with firmware version 5.00.

To configure the display value, navigate to the DISPLAY menu selection and press Enter. Use the Next button to select SHOW M1, SHOW M2, or TOGGLE and press Enter.

## CALDATE:

This is not a required entry but can be used for recordkeeping or plant maintenance purposes. To edit the calibration date, go to CALDATE with the Next button and press Enter. You then can change the day, month, and year. The display shows the last date with the day flashing. Use the Next button to step through the library of digits to select the desired day, then press Enter. Repeat this process for the month and year.

## ENA PWD:

To enable or disable the password feature, go to ENA PWD with the Next button and press Enter. Use the Next button to select NO PWDS (password not required for either

calibration or configuration), CFGONLY (password required to configure but not to calibrate), or CFG+CAL (passwords required to both configure and calibrate) and press Enter.

If you selected CFG ONLY, the display changes to CFG PWD. Press either the Next or Enter button. Use the Next button to step through the library of characters to select the desired first character, then press Enter. Your selection is entered and the second character flashes. Repeat this procedure until you have created your password. If the password has less than six characters, use blanks for the remaining spaces. When you have configured the sixth space, the display advances to the next menu item.

If you selected CFG+CAL, the display changes to CAL PWD. To create the Calibration password, press either the Next or Enter button. Use the Next button to step through the library of characters to select the desired first character, then press Enter. Your selection is entered and the second character flashes. Repeat this procedure until you have created your password. If the password has less than six characters, use blanks for the remaining spaces. When you have configured the sixth space, the display advances to CFG PWD. Use the same procedure to create the configuration password.

---

— **NOTE** —

In normal operation, the CAL PWD allows access to only calibration mode. The CFG PWD allows access to both configuration and calibration.

---

---

—  **CAUTION** —

Record your new password before saving changes to the database.

---

### SET GDB:

If your transmitter database becomes corrupted and you receive an INITERR message upon startup, this function enables you to rewrite all calibration and configuration values with default values.

---

—  **CAUTION** —

Any calibration and configuration values that you have entered will be lost. Therefore, SET GDB should **not** be selected if your transmitter is functioning normally.

---

## Character Lists

*Table 6. Alphanumeric Character List*

Characters
(space)
%
*
+
–
/
0 through 9
<
=
>
A through Z (uppercase)
[
\
]
Δ
- (underscore)
∇
a through z (lowercase)

*Table 7. Numeric Character List*

Characters
– (minus sign)
. (decimal point)
0 through 9

## Configuration Using a FOUNDATION Fieldbus Host

The transmitter can be configured from the optional local display or from a FOUNDATION fieldbus host. Some of the parameters can be configured from either the display and the host; others can be configured only from the display or the host.

---

**— NOTE —**

After writing changes to your transmitter, wait at least 30 seconds before disconnecting your transmitter or otherwise removing power from it.

---

## Configuration Procedure Using a FOUNDATION Fieldbus Host

---

**— NOTE —**

This procedure is for transmitters with a DEV\_REV of 30 HEX (48 DEC) or higher.

---

A FOUNDATION fieldbus system is composed of two main parts: A Control Application Process (CAP) and a Device Application Process (DAP). The CAP contains the Resource Block, the Analog Input Blocks, and a PID Block if one is used. The contents of these blocks are defined by the Fieldbus Foundation and are configured by the host, often using a template that has been developed. The DAP contains the Transducer Block. Its contents vary with the product and are usually configured by an operator using fieldbus configurator software.

Therefore, this configuration procedure will concentrate on setting the configurable parameters in the Transducer Block. It will also describe scaling parameters in the Analog Input Blocks that also must be set.

### *Configuring the Transducer Block*

1. Open the Transducer Block. Put the block Out Of Service by setting `MODE_BLK • Target` to OOS.
2. Set the `PRIMARY_VALUE_RANGE • UNITS_INDEX` to a pressure engineering unit, such as inH2O, kg/cm2, and so forth. For unit codes, see Table 8.
3. Set the `THIRD_VALUE_TYPE` to Pressure Linear. `Flow_comp_with_zero_cutoff` and `Flow_comp_with_linear_extrapolation` are not valid for absolute and gauge pressure transmitters.
4. Set the `THIRD_VALUE_RANGE • UNITS_INDEX` to match the units in `XD_SCALE` for the AI Block connected to this channel.
5. The factory setting for `SENSOR_DAMPING` is 0. If the process is noisy, increase the value in small increments, up to 32 seconds maximum. Select one of the following numbers: 0, 0.25, 0.50, 1, 2, 4, 8, 16 or 32.
6. Write the changes to the transmitter.

*Table 8. Unit names and Unit Codes*

Unit Name	Unit Code	Unit Name	Unit Code	Unit Name	Unit Code	Unit Name	Unit Code
Pa	1130	torr	1139	kgcm2	1145	mmHg0C	1158
MPa	1132	atm	1140	inH2O	1146	cmHg	31500
kPa	1133	psia	1142	mmH2O20 C	1151	cmH2O	31502
bar	1137	psig	1143	ftH2O20C	1154	dycm2	31572
mbar	1138	gcm2	1144	inHg	1155		

### *Configuring the Scaling Parameters in the Analog Input Block*

1. Open the Analog Input Block. Put the block Out Of Service by setting `MODE_BLK • Target` to OOS.

2. The CHANNEL parameter can be set to any of the following, depending upon what measurement you want to use:

CHANNEL Number	CHANNEL Parameter	Transducer Block Value Used By AI Block
1	Pressure	Primary Value
2	Sensor Temperature	Secondary Value (Transmitter Temperature)
3	Flow	Third Value

3. The S Temperature is the temperature inside the pressure sensor used for compensation purposes. It may not be equal to the ambient temperature. It definitely is not the process temperature, and therefore should not be used for control purposes.
4. Write the changes to the transmitter.
5. Set the XD\_SCALE, L\_TYPE, and OUT\_SCALE parameters as follows:

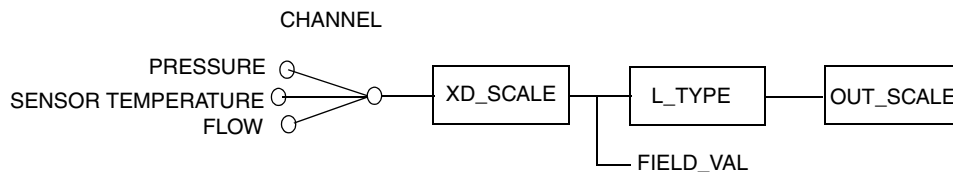

NOTE: FIELD\_VAL IS THE MEASUREMENT IN % OF XD\_SCALE

**a. If CHANNEL is set for Pressure:**

- ◆ Set the XD\_SCALE•UNITS\_INDEX exactly the same as the PRIMARY\_VALUE\_RANGE•UNITS\_INDEX.
- ◆ Set the XD\_SCALE range to the desired range. It doesn't have to match the PRIMARY\_VALUE\_RANGE values.
- ◆ If L\_TYPE is Direct, set the OUT\_SCALE parameters to match those of the XD\_SCALE.
- ◆ If L\_TYPE is Indirect, set the OUT\_SCALE at the desired unit and values.
- ◆ L\_TYPE Indirect Sq Rt is not applicable.

**b. If CHANNEL is set for Sensor Temperature:**

- ◆ Set the XD\_SCALE•UNITS\_INDEX to °C.
- ◆ Set the XD\_SCALE range to the desired range. Note that your transmitter can only read values within the range of (-50 to +105°C).
- ◆ If L\_TYPE is Direct, set the OUT\_SCALE parameters to match those of the XD\_SCALE.
- ◆ If L\_TYPE is Indirect, set the OUT\_SCALE at the desired unit and values. See example below.
- ◆ L\_TYPE Indirect Sq Rt is not applicable.

### Example of Using Indirect L\_TYPE

If you wanted to output sensor temperature from 0 to 100°C in degrees Fahrenheit:

- ◆ Set the XD\_SCALE•UNITS\_INDEX to °C.
  - ◆ Set the XD\_SCALE: EU\_at\_100% to 100, EU\_at\_0% to 0, and UNITS\_INDEX to °C.
  - ◆ Set the L\_TYPE as Indirect.
  - ◆ Set the OUT\_SCALE: EU\_at\_100% to 212, EU\_at\_0% to 32, and UNITS\_INDEX to °F. These are the equivalent values in °F of 100°C and 0°C respectively.
- c. **If CHANNEL is set for Flow and THIRD\_VALUE\_TYPE is Pressure Linear:**
- ◆ Set the XD\_SCALE•UNITS\_INDEX exactly the same as the THIRD\_VALUE\_RANGE•UNITS\_INDEX.
  - ◆ Set the XD\_SCALE range to the desired range. It doesn't have to match the THIRD\_VALUE\_RANGE values.
  - ◆ If L\_TYPE is Direct, set the OUT\_SCALE parameters to match those of the XD\_SCALE.
  - ◆ If L\_TYPE is Indirect, set the OUT\_SCALE at the desired unit and values.
  - ◆ L\_TYPE Indirect Sq Rt is not applicable.
6. Write the changes to the transmitter.

## Application Specific Configurations

Tables 9 and 10 show typical configuration parameters for various applications. Additional parameter configuration is required for various applications.

*Table 9. Pressure Applications*

Application Parameters		Application 1	Application 2	Application 3
Application		Pressure	Pressure	Pressure
Calibrated Range		0 to 50 PSI	0 to 75 Kg/cm2	0 to 200 Bar
Transmitter output		0 to 50 PSI	0 to 75 Kg/cm2	0 to 100%
Indicator displays		0 to 50 PSI	0 to 75 Kg/cm2	0 to 200 Bar
After pushing Enter key on indicator, the indicator displays		0 to 50 PSI	0 to 75 Kg/cm2	0 to 200 Bar
Output of AI #1 to host system		0 to 50 PSI	0 to 75 Kg/cm2	0 to 100%
Output of AI #2 (internal temperature) to host system		°F	°C	°F
Block	Parameter Name	Configuration	Configuration	Configuration
TB	PRIMARY_VALUE_RANGE - EU_100	50	75	200
	PRIMARY_VALUE_RANGE - EU_0	0	0	0
	PRIMARY_VALUE_RANGE - UNITS_INDEX	PSI	Kg/cm2	Bar
AI #1	CHANNEL	Pressure	Pressure	Pressure
	XD_SCALE - EU_100	50	75	200
	XD_SCALE - EU_0	0	0	0
	XD_SCALE - UNITS_INDEX	PSI	Kg/cm2	Bar
	L_TYPE	Direct	Direct	Indirect
	OUT_SCALE - EU_100	50	75	100
	OUT_SCALE - EU_0	0	0	0
AI #2	CHANNEL	S Temp	S Temp	S Temp
	XD_SCALE - EU_100	105	105	105
	XD_SCALE - EU_0	-50	-50	-50
	XD_SCALE - UNITS_INDEX	°C	°C	°C
	L_TYPE	Indirect	Direct	Indirect
	OUT_SCALE - EU_100	220	105	220
	OUT_SCALE - EU_0	-58	-50	-58
OUT_SCALE - UNITS_INDEX	°F	°C	°F	

Table 10. Open Tank Applications

Application Parameters		Application
Application		Open Tank (see Note)
Calibrated Range		0 to 50 inH <sub>2</sub> O
Transmitter output		0 to 40 inches
Indicator displays		0 to 50 inH <sub>2</sub> O
After pushing Enter key on indicator, the indicator displays		0 to 50 inH <sub>2</sub> O
Output of AI #1 to host system		0 to 40 inches
Output of AI #2 (internal temperature) to host system		°F
Block	Parameter Name	Configuration
TB	PRIMARY_VALUE_RANGE - EU_100	50
	PRIMARY_VALUE_RANGE - EU_0	0
	PRIMARY_VALUE_RANGE - UNITS_INDEX	inH <sub>2</sub> O
AI #1	CHANNEL	Pressure
	XD_SCALE - EU_100	50
	XD_SCALE - EU_0	0
	XD_SCALE - UNITS_INDEX	inH <sub>2</sub> O
	L_TYPE	Indirect
	OUT_SCALE - EU_100	40 (see Note)
	OUT_SCALE - EU_0	0
OUT_SCALE - UNITS_INDEX	in	
AI #2	CHANNEL	S Temp
	XD_SCALE - EU_100	105
	XD_SCALE - EU_0	-50
	XD_SCALE - UNITS_INDEX	°C
	L_TYPE	Indirect
	OUT_SCALE - EU_100	220
	OUT_SCALE - EU_0	-58
OUT_SCALE - UNITS_INDEX	°F	

**— NOTE —**

In this example, the fluid level change is 40 inches, with a specific gravity of 1.25, which results in a range of 0 to 50 inH<sub>2</sub>O.

## Changing the Primary Range Values (Reranging) by Editing the Transducer Block Parameters

1. Open the Transducer Block. Put the block Out Of Service by setting `MODE_BLK` • Target to OOS.
2. Set the `PRIMARY_VALUE_RANGE` sub-parameters as follows:
  - `EU_100`    enter the 100% value of the calibrated range desired
  - `EU_0`      enter the 0% value of the calibrated range desired
3. Write the changes to the transmitter.
4. Calibrate the transmitter. Refer to “Calibration” on page 29.

5. Set the Target Mode in the Transducer Block to **Auto**. Make sure that the **MODE\_BLK**
  - **ACTUAL** value reads **Auto**. Once in the Auto mode, the **PRIMARY\_VALUE** and **SECONDARY\_VALUE** should display the appropriate values. If not, check the Maintenance section. If the block does not change to **Auto**, go to **BLOCK\_ERR\_DESC\_1** to see what is wrong. Fix the problem and close the Transducer Block window.
6. Reconfigure the **CHANNEL**, **XD\_SCALE**, **L\_TYPE**, and **OUT\_SCALE** parameters in the Analog Input Block as necessary. See “Configuring the Scaling Parameters in the Analog Input Block” on page 47.

## Disabling the Link Active Scheduler (LAS)

To disable the LAS, right mouse click on **DEV\_TAG** and set “Device Type = yes” to OK.

---

### — NOTE —

If more than one device has the LAS feature configured on, the LAS is applied to the devices in the order of their Node Address. Therefore, take LAS into consideration when selecting the Node Address.

---



---

### — CAUTION —

Do not modify the parameters in the Link Settings (Advanced) tab without good reason. If you must modify parameters for certain transmitters, Invensys will recommend settings. Modifying these parameters can have an adverse affect on data throughput rates. If settings are incorrectly modified, some devices may disappear from the network.

---



---

### — NOTE —

Invensys recommends, as a prudent measure, that multiple devices (two or more) on the bus be configured as link master devices.

---

# 6. Maintenance

---

— **! DANGER** —

For nonintrinsically safe installations, to prevent a potential explosion in a Division 1 hazardous area, de-energize transmitters before you remove threaded housing covers. Failure to comply with this warning could result in an explosion resulting in severe injury or death.

---

---

— **NOTE** —

After writing changes to your transmitter, wait at least 30 seconds before disconnecting your transmitter or otherwise removing power from it.

---

## Troubleshooting

### Simulation Mode

The transmitter has a simulation capability that can be used for debugging/troubleshooting the system when the process is not running. Once the simulation jumper is set, the user can select any value as the input to the AI Block for testing or debugging purposes. The procedure is as follows:

1. Place the appropriate AI Block in Out of Service (OOS) mode using the configurator software.
2. Remove the housing cover and the optional indicator.
3. To activate Simulation mode, move the simulation jumper to the lower position as shown in Figure 23.

*Figure 23. Simulation Jumper*

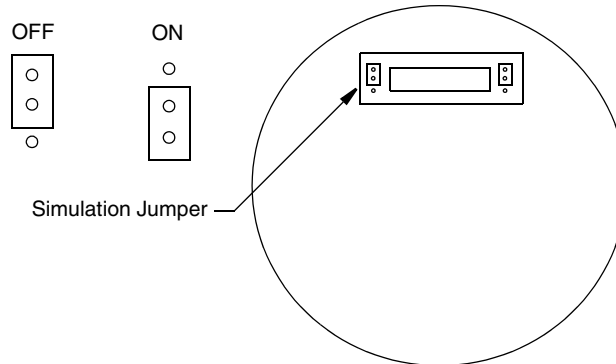

4. Replace the indicator and housing cover, if desired.
5. Set the `SIMULATE_ENABLE • DISABLE` to Active
6. Set the `SIMULATE_STATUS_QUALITY` to `Good_NonCascade` (suggested setting) or other appropriate setting.

7. Type in the value you want as the output from the Transducer Block in the `Simulate_Value` parameter.
8. Click on the **Write Changes** button. If you try to send a simulated output without putting the jumper in the correct position (step #2), the software will not change anything (device did not accept this parameter value) and you will get an error response.
9. Set the AI Block to **AUTO** mode
10. Proceed with troubleshooting remembering that the output of the AI Block has been set by the value typed in step #7
11. After completion of troubleshooting, set the AI Block to **Out of Service (OOS)**
12. Set the `SIMULATE_ENABLE_DISABLE` to **Disabled**
13. Click on the **Write Changes** button.
14. Place the AI Block in **AUTO** mode using the configurator software. Make sure the `MODE_BLK • ACTUAL` reads **AUTO**.
15. Reset the jumper moved in Step 3.
16. Reassemble electronic module, indicator and housing cover.

## Restart

The **RESTART** parameter in the Resource Block should only be used when the configuration in the transmitter is incorrect and you cannot fix the problem by using the troubleshooting information in this section. In all cases, try cycling the power to the transmitter first. Then go back to the block with the problem and try to write the changes to the transmitter. If that does not clear the problem, proceed with the **RESTART** procedure.

---

### CAUTION

When you do a “Defaults” **RESTART** command in the Resource Block, the configured parameters will automatically default to the status and values predetermined by the Foundation. These are the same as the initial factory settings shown in Appendix A for the Resource, Analog Input, and PID Blocks but are different than those shown for the Transducer Block.

---

1. Open the Resource Block and put it in the **OOS** mode.
2. Open the **RESTART** box and select one of the following:
  - ◆ **Uninitialized** – do not use (may not appear on list)
  - ◆ **Run** – this is the default setting, the nominal state when not restarting
  - ◆ **Defaults** – Sets the parameters to the Foundation defaults, which may be different than the initial factory settings. This will reset all configurable function block application objects. It will also clear all configured Trend and Link Objects. A restart of the processor will also be performed automatically after re-initialization has been completed.
  - ◆ **Processor** – does a warm restart of CPU and has the same effect as cycling the power (**OFF/ON**) to the transmitter

3. Click on the **Write Changes** button.
4. Put the Resource Block back into AUTO mode (the RESTART selection will automatically default to the Run position).
5. Reconfigure the appropriate function blocks.

## Switch Mode Checklist

1. Verify that the block is scheduled. (Note that resource block and transducer block are always scheduled.)
2. Check the error messages in the `BLOCK_ERR_DESC_1` parameter.
3. Verify that resource block is in Auto Mode.
4. Verify that requested mode is permitted.

## Schedule Download Checklist

1. Verify that all blocks in the network have different tags.
2. Verify that no two blocks from the same devices are scheduled to be executed at the same time.
3. Verify that there is enough time for block execution.

## Block Errors

Table 11 lists all of the possible error codes in the various function blocks. Not all error codes are possible in all of the blocks. The condition number is shown in the `BLOCK_ERR` parameter for all blocks (and in the `XD_ERROR` in the Transducer Block).

*Table 11. Block Errors*

Bit Number	Name and Description
0	No Error
1	Block Configuration Error: (See Table 12)
2	Link Configuration Error: A link used in one of the function blocks is improperly configured.
3	Simulate Active: The Simulation jumper is enabled. This is not an indication that the I/O blocks are using simulated data.
4	Local Override:
5	Device Fault State Set:
6	Device Needs Maintenance Soon:
7	Input Failure/Process Variable Has Bad Status: The hardware is bad, an input is not connected, or a status is being simulated.
8	Output Failure: The output is bad based primarily upon a bad input.
9	Memory Failure: A memory failure has occurred in Flash, RAM or EEPROM memory.
10	Lost Static Data: Static data stored in non-volatile memory has been lost.
11	Lost NV Data: Non-volatile data stored in non-volatile memory has been lost.
12	Readback Check Failed:

*Table 11. Block Errors (Continued)*

Bit Number	Name and Description
13	Device Needs Maintenance Now:
14	Power Up: The Device was just powered - wait
15	Out Of Service: The actual mode is OSS, change to AUTO

*Table 12. Configuration Errors*

Error	Description
Resource Block	
All Static Parameters are Reset	Device needs a complete download
Analog Input (AI) Block	
$XD\_SCALE.EU\_0 \geq XD\_SCALE.EU\_100$	Low end of scale must be less than high end
$OUT\_SCALE.EU\_0 \geq OUT\_SCALE.EU\_100$	Low end of scale must be less than high end
$OUT\_SCALE = XD\_SCALE$ and $L\_TYPE = Direct$	Scales must match if $L\_TYPE$ is Direct
$XD\_SCALE.UNITS\_INDEX \neq$ Pressure Channel Units	Units in Transducer Block and AI Block must match
$XD\_SCALE.UNITS\_INDEX \neq$ Temperature Channel Units	Units in Transducer Block and AI Block must match
$XD\_SCALE.UNITS\_INDEX \neq$ Flow Channel Units	Units in Transducer Block and AI Block must match
AI Block not scheduled	AI Block must be scheduled to run by a host
Invalid Channel	AI Block Channel must be 1, 2, or 3
Proportional Integral, Derivative (PID) Block	
SP not initialized	SP has never been written
BYPASS not initialized	BYPASS must be set to On or Off
SHED_OPT not initialized	SHED_OPT must be initialized for ROUT and RCAS modes
GAIN not initialized	GAIN must be greater than zero
$OUT\_SCALE.EU\_0 \geq OUT\_SCALE.EU\_100$	Low end of scale must be less than high end
$PV\_SCALE.EU\_0 \geq PV\_SCALE.EU\_100$	Low end of scale must be less than high end
$FF\_SCALE.EU\_0 \geq FF\_SCALE.EU\_100$	Low end of scale must be less than high end
$TRK\_SCALE.EU\_0 \geq TRK\_SCALE.EU\_100$	Low end of scale must be less than high end
PID Block not scheduled	PID Block must be scheduled to run by a host

## Interboard Communication Errors/Status

The `SENSOR_STATUS` parameter in the Transducer Block reflects the state of the sensor board. If the state is normal, `SENSOR_STATUS` indicates the following:

```
SENSOR_STATUS
SENSOR_STATUS No Parameter Offset
```

If something occurs that affects the state of the sensor board, a status message will be posted, for example:

```
SENSOR_STATUS  Sensor Board is offline due to config  
SENSOR_STATUS  No Parameter Offset
```

which indicates the sensor interface is offline because someone is attempting to configure the transmitter via the local LCD display.

If a particular parameter is at fault it is displayed in the second portion of SENSOR\_STATUS.

The following is a list of all the possible status messages:

1. No serial comm between Sensor and MAU
2. Sensor board is busy
3. Sensor board-Change to ONLINE failed after Re-Init
4. Sensor board is not in ONLINE mode
5. Sensor board M1\_MODE is not LINEAR
6. Sensor board is not good for Pressure measurement
7. Sensor board M1EOFF or M2EOFF parameter is not ZERO
8. Sensor board M2 mode 'OFF' is selected
9. Sensor board M1DAMP parameter is not zero
10. EGU for M1 is not supported
11. EGU for M2 is not supported
12. Sensor board M2EGU should be '%flow
13. Transducer Block Initializing
14. EEPROM Error
15. Sensor Database is updating
16. Sensor Board is offline due to cal
17. Sensor Board is offline due to config
18. Sensor Board is Out Of Service

In general, any message that is permanently displayed or keeps returning for unknown reasons indicates a hardware failure of the sensor board and the board needs service.

## Parts Replacement

Parts replacement is generally limited to the electronics module assembly, housing assembly, sensor assembly, terminal block assembly, cover O-rings, and optional display. For part numbers relating to the transmitter and its options, see PL 009-007.

## Replacing the Terminal Block Assembly

1. Turn off transmitter power source.
2. Remove the Field Terminals and the Electronics compartment covers by rotating them counterclockwise. Screw in cover lock if applicable.
3. Remove the digital display (if applicable) as follows: grasp the two tabs on the display and rotate it about 10° in a counterclockwise direction.
4. Remove the electronics module from the housing by loosening the two captive screws that secure it to the housing. Then pull the module out of the housing far enough to gain access to the cable connectors on the rear of the module.
5. Remove the four socket head screws securing the terminal block.
6. Disconnect the terminal block cable connector from the electronics module.
7. Remove the terminal block and the gasket under it.
8. Connect the new terminal block cable connector to the electronics module.
9. Install the new terminal block and new gasket and reinstall the four screws to 0.67 N·m (6 in·lb) in several even increments.
10. Reinstall the electronics module (and digital display if applicable).
11. Reinstall the covers onto the housing by rotating them clockwise to seat the O-ring into the housing and then continue to hand tighten until the each cover contacts the housing metal-to-metal. If cover locks are present, lock the cover per the procedure described in “Cover Locks” on page 19.
12. Turn on transmitter power source.

## Replacing the Electronics Module Assembly

To replace the electronics module assembly, refer to Figure 24 and proceed as follows:

1. Turn off transmitter power source.
2. Remove the electronics compartment cover by rotating it counterclockwise. Screw in cover lock if applicable.
3. Remove the digital display (if applicable) as follows: grasp the two tabs on the display and rotate it about 10° in a counterclockwise direction. Pull out the display and disconnect its cable.
4. Remove the electronics module from the housing by loosening the two captive screws that secure it to the housing. Then pull the module out of the housing far enough to gain access to the cable connectors on the rear of the module.

---

### CAUTION

The electronics module is “one assembly” at this point and is electrically and mechanically connected to topworks with a flexible ribbon signal cable, a 2-wire power cable, and in some cases, a cable for an external zero pushbutton. Do **not** exceed the slack available in these cables when removing the assembled module.

---

5. Unplug all cable connectors from the rear of the electronics module and place the module on a clean surface.
6. Predetermine connector orientation, then insert the cable connectors into the replacement module. Replace the module in the housing using care not to pinch the cables between the module and the housing. Tighten the two screws that secure the module to the housing.
7. Connect the cable from the digital display to the electronics module. Ensure that the O-ring is fully seated in the display housing. Then, holding the digital display by the tabs at the sides of the display, insert it into the housing. Secure the display to the housing by aligning the tabs on the sides of the assembly and rotating it about 10° in a clockwise direction.
8. Reinstall the cover onto the housing by rotating it clockwise to seat the O-ring into the housing and then continue to hand tighten until the cover contacts the housing metal-to-metal. If cover locks are present, lock the cover per the procedure described in “Cover Locks” on page 19.
9. Turn on transmitter power source.

The module replacement procedure is now complete.

*Figure 24. Replacing the Electronics Module Assembly and Display*

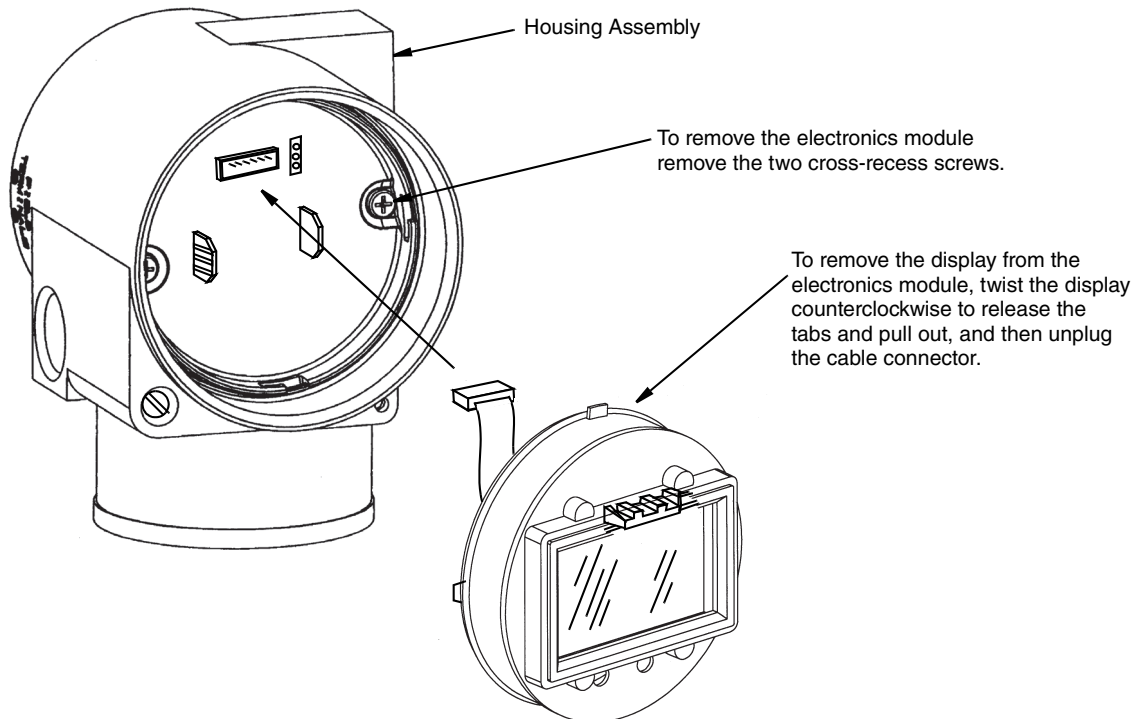

## Removing and Reinstalling a Housing Assembly

To remove and reinstall a housing assembly, refer to Figure 24 and proceed as follows:

1. Remove the electronics module per Steps 1 through 5 in the previous procedure.
2. If your housing has an anti-rotation screw, remove the red lacquer from the screw recess. Turn the screw three full turns counterclockwise.
3. If your housing has a retention clip, remove the red lacquer from the screw recess. Remove the screw completely, and slide the clip off the housing. Save the clip and screw for future use,
4. Remove the housing by rotating it counterclockwise (when viewed from the top). Use caution to avoid damaging the sensor cable.
5. Inspect the sensor O-ring for damage. If the O-ring is damaged, replace it with the appropriate O-ring. (See parts list for your transmitter). Lubricate the O-ring with silicone lubricant (Invensys Part Number 0048130 or equivalent). Verify that the O-ring is situated in the groove of the neck.

---

**! WARNING**

Failure to reuse or install the proper O-ring for a CSA labeled product violates ANSI / ISA 12.27.01.

---

6. Feed the sensor cable through the housing neck into the electronics compartment.
7. Screw the housing onto the sensor neck until it bottoms. Do not over tighten. Be careful not to damage the sensor cable or dislodge the neck O-ring.
8. If your housing has an anti-rotation screw, engage the screw until it touches the sensor neck and back it off 1/8th turn. It is important that the screw is not touching the sensor. Fill the screw recess with red lacquer (Invensys Part Number X0180GS or equivalent). the housing may then be rotated up to one full turn counterclockwise for optimum access.
9. If your housing has a retention clip, insert the clip over the boss in the housing neck so that the hole in the clip is aligned with the hole in the boss. Install the screw but do not tighten. Rotate the housing up to one full turn counterclockwise for optimum access. Tighten the retention clip screw and fill the screw recess with red lacquer (Invensys Part Number X0180GS or equivalent). The housing can still be rotated for optimum access.
10. Reinstall the electronics module per Steps 6 through 9 in the previous procedure.

## Adding the Optional Display

To add the optional display, refer to Figure 24 and proceed as follows:

1. Turn off transmitter power source.
2. Remove the electronics compartment cover by rotating it counterclockwise. Screw in cover lock if applicable.
3. Plug the display into the receptacle at the top of the electronics assembly.

4. Ensure that the O-ring is seated in its groove in the display housing. Then insert the display into the electronics compartment by grasping the two tabs on the display and rotating it about 10° in a clockwise direction.
5. Install the new cover (with a window) onto the housing by rotating it clockwise to seat the O-ring into the housing and then continue to hand tighten until the cover contacts the housing metal-to-metal. If cover locks are present, lock the cover per the procedure described in “Cover Locks” on page 19.
6. Turn on transmitter power source.

## Replacing the Sensor Assembly

To replace the sensor assembly, refer to Figures 25 and 26 and proceed as follows:

1. Remove the electronics module as described above.
2. Remove the housing as described above.
3. Remove the process covers from sensor by removing two hex head bolts.
4. Replace the gaskets in the process covers.
5. Install the process covers and housing on the new sensor. Torque cover bolts to 100 N·m (75 lb·ft) in several even increments. Torque values are 68 N·m (50 lb·ft) when 316 ss bolts are specified; 75 N·m (55 lb·ft) when B7M bolts are specified.
6. Reinstall electronics module.
7. Pressure test the sensor and process cover assembly by applying a hydrostatic pressure of 150% of the maximum static and overrange pressure rating to both sides of the process cover/sensor assembly simultaneously through the process connections. Hold pressure for one minute. There should be no leakage of the test fluid through the gaskets. If leakage occurs, retighten the cover bolts per Step 5 (or replace the gaskets) and retest.

**! CAUTION**  
Perform hydrostatic test with a liquid and follow proper hydrostatic test procedures.

*Figure 25. Replacing the Sensor Assembly*

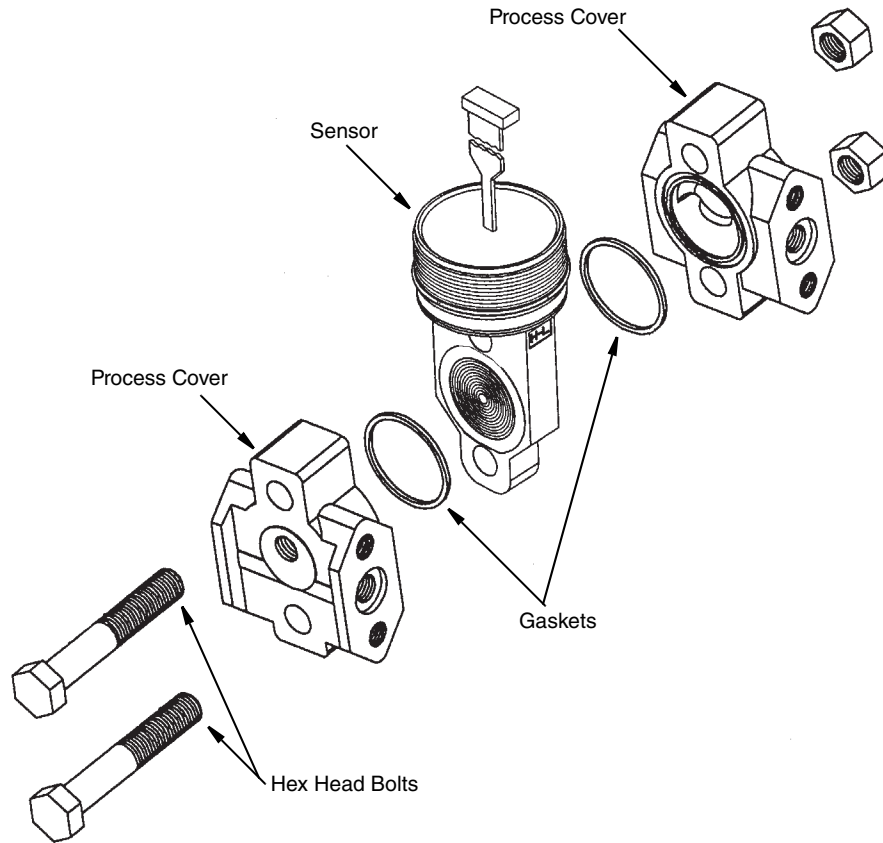

*Figure 26. Replacing the Sensor Assembly (PVDF Inserts)*

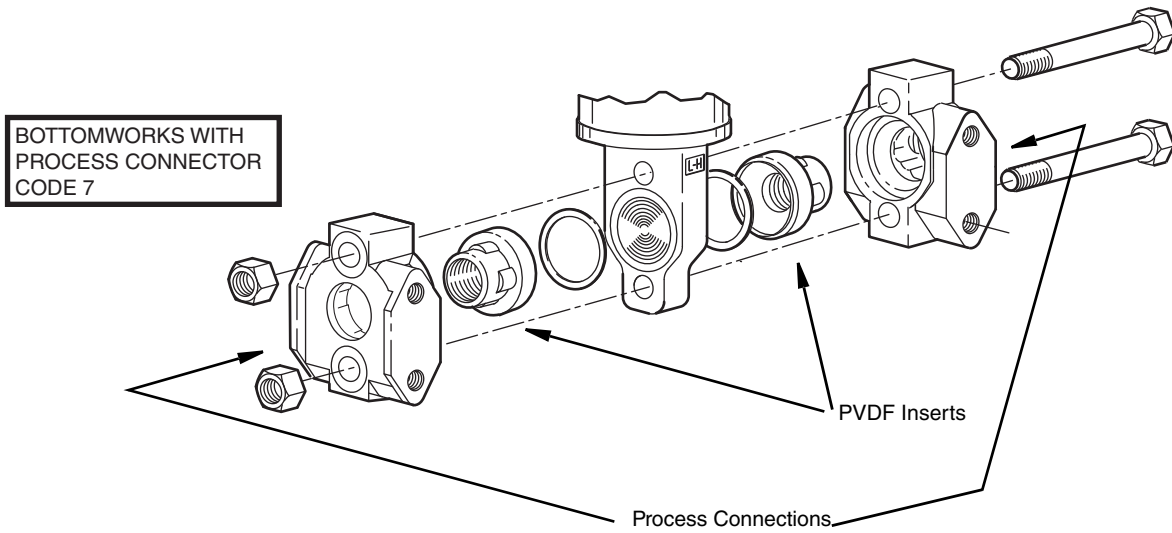

## Rotating Process Covers for Venting

As received, your IASPT Transmitter provides sensor cavity draining without the need for side drain connections, regardless of whether the transmitter is mounted vertically or horizontally. Sensor cavity venting is provided by mounting the transmitter horizontally or with the optional vent screw (-V). However, if you did not specify this option, you can still achieve venting (instead of draining) with vertical mounting by rotating the process covers.

*Figure 27. Sensor Cavity Venting and Draining*

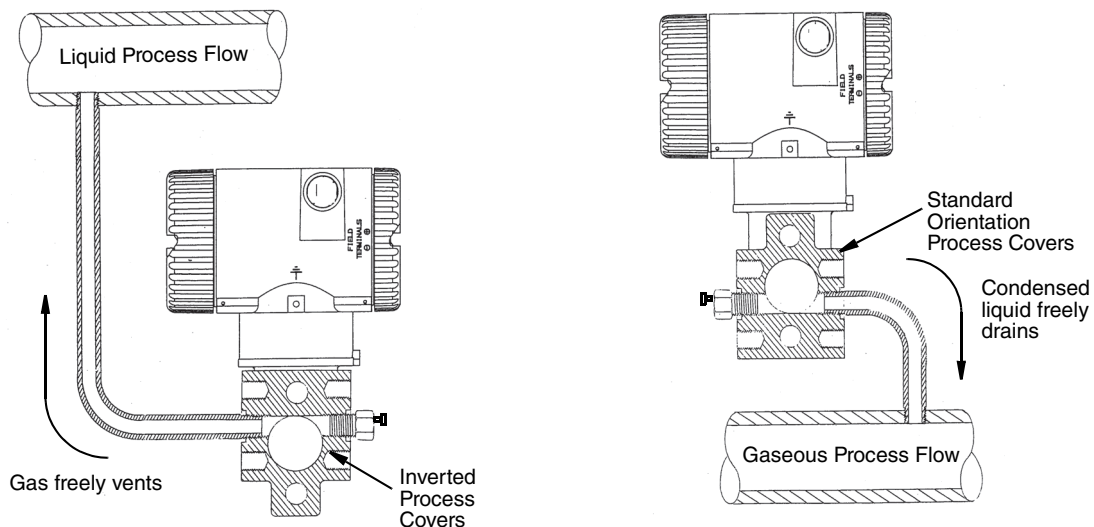

To rotate the process covers, refer to the figure in “Replacing the Sensor Assembly” and proceed as follows:

1. Turn off the transmitter power source and remove the transmitter from the process.
2. Remove the process covers from sensor by removing two hex head bolts.
3. Replace gaskets in process covers.
4. Rotate the process covers so that the longer tab is at the bottom.
5. Reinstall process covers and bolts. Torque cover bolts to 100 N·m (75 lb·ft) in several even increments. Torque values are 68 N·m (50 lb·ft) when 316 ss bolts are specified; 75 N·m (55 lb·ft) when B7M bolts are specified.
6. Pressure test the sensor and process cover assembly by applying a hydrostatic pressure of 150% of the maximum static and overrange pressure (see “Standard Specifications” on page 5) to both sides of the process cover/sensor assembly simultaneously through the process connections. Hold pressure for one minute. There should be no leakage of the test fluid through the gaskets. If leakage occurs, retighten the cover bolts per Step 4 or replace the gaskets and retest.

---

**! CAUTION**

Perform hydrostatic test with a liquid and follow proper hydrostatic test procedures.

---



# Appendix A. List of Parameters

Table 13. FOUNDATION Fieldbus Parameters

Rel Index	Parameter Name	RO or R/W	Initial Factory Settings	Comments
<b>Network Configuration</b>				
	PD_TAG	R/W	Unique Device ID	
	NODE_ADDRESS	R/W	Unique to a segment	
<b>Resource Block</b>				
	BLOCK_TAG	R/W	RB(300)	Unique Block ID
1	ST_REV	RO	current rev	Static Data revision level
2	TAG_DESC	R/W	blank	User description of the block application
3	STRATEGY	R/W	0	To ID groups of blocks
4	ALERT_KEY	R/W	0	ID number of the plant unit
5	MODE_BLK			
	Target	R/W	OOS	Mode requested by operator
	Actual	RO	OOS	The current mode of the block
	Permitted	R/W	Auto, OOS	Modes allowed for this block
	Normal	R/W	Auto	Mode of block during normal operations
6	BLOCK_ERR	RO	OutOfService	Error status of the hardware or software
7	RS_STATE	RO	Standby	State of the function block application
8	TEST_RW	R/W		Test parameter used only for conformance testing.
9	DD_RESOURCE	RO		Tag of the resource identifying the DD
10	MANUFAC_ID	RO	Foxboro	Manufacturer ID number
11	DEV_TYPE	RO	BA30	Manufacturer Model number
12	DEV_REV	RO	current device rev	Device revision number
13	DD_REV	RO	01	Initial DD revision number
14	GRANT_DENY			Options for controlling access of host computers and local control panels to operating, tuning, and alarm parameters.
	Grant	R/W	0 (none selected)	
	Deny	R/W	0 (none selected)	
15	HARD_TYPES	RO	Scalar Input	Type of hardware available to this resource
16	RESTART	R/W	Run	Defines the type of restart to be initiated
17	FEATURES	RO	Reports, Hard W Lock Chg Bypass in Auto	Shows supported Resource Block options
18	FEATURE_SEL	R/W	Hard W Lock	Used to select Resource Block options
19	CYCLE_TYPE	RO	Scheduled Block execution	Block execution methods available
20	CYCLE_SEL	R/W	0 (none selected)	Used to select Cycle Type
21	MIN_CYCLE_T	RO	1900 1/32 ms	Duration of the shortest cycle interval
22	MEMORY_SIZE	RO	0	Available config memory in the empty resource
23	NV_CYCLE_T	RO	480000 1/32 ms	Interval between writes to nonvolatile memory
24	FREE_SPACE	RO	0	% of memory available for further configuration
25	FREE_TIME	RO	0	% of block processing time available
26	SHED_RCAS	R/W	640000 1/32 ms	Timeout for write attempts to RCas locations
27	SHED_ROUT	R/W	640000 1/32 ms	Timeout for write attempts to ROut locations

Table 13. FOUNDATION Fieldbus Parameters (Continued)

Rel Index	Parameter Name	RO or R/W	Initial Factory Settings	Comments
28	FAULT_STATE	RO	Clear	When active, causes all output function blocks in the resource to go to the condition chosen by the fault state Type I/O option
29	SET_FSTATE	R/W	Off	Allows faultstate conditions to be manually set
30	CLR_FSTATE	R/W	Off	Allows faultstate conditions to be cleared
31	MAX_NOTIFY	RO	8	Maximum number of unconfirmed alert notify messages possible
32	LIM_NOTIFY	R/W	8	Maximum number of unconfirmed alert notify messages allowed
33	CONFIRM_TIME	R/W	640000 1/32 ms	Minimum time between retries of alert reports
34	WRITE_LOCK	R/W	Not Locked	Locked setting prevents writing changes if FEATURE_SEL is set to Hard W Lock and the write protection jumper is in the locked position.
35	UPDATE_EVT	RO		Generated by any change to static data of the block
36	BLOCK_ALM	RO		For all configuration, hardware, connection failure, or system problems
37	ALARM_SUM			The current alert status
	Current	RO	0	The active state of each alarm
	Unacknowledged	RO	0	The unacknowledged state of each alarm
	Unreported	RO	0	The unreported state of each alarm
	Disabled	R/W	no alarms disabled	The disabled state of each alarm
38	ACK_OPTION	R/W	no alarms auto ack'd	Selection of which alarms are automatically acknowledged
39	WRITE_PRI	R/W	0	Priority of alarm generated by clearing write lock
40	WRITE_ALM	RO		Alert generated if the write lock parameter is cleared
41	ITK_VER	RO	5	Revision to which the DD has been tested
42	BLOCK_ERR_DESC_1	RO	0	Details of a block error.
<b>Transducer Block</b>				
	BLOCK_TAG	R/W	TR(550)	Unique Block ID
1	ST_REV	RO	current rev	Static data revision
2	TAG_DESC	R/W	blank	User description of the block application
3	STRATEGY	R/W	0	To ID groups of blocks
4	ALERT_KEY	R/W	0	ID number of plant unit
5	MODE_BLK			
	Target	R/W	Auto	Mode requested by operator
	Actual	RO	Auto	The current mode of the block
	Permitted	R/W	Auto, OOS	Modes allowed for this block
	Normal	R/W	Auto	Mode of block during normal operations
6	BLOCK_ERR	RO	OutOfService	Error status of the hardware or software
7	UPDATE_EVT	RO		Generated by any change to static data of the block
8	BLOCK_ALM	RO		For all configuration, hardware, connection failure, or system problems
9	TRANSDUCER_DIRECTORY	RO	0	Dir that specifies the number & start of data collection
10	TRANSDUCER_TYPE	RO	Std press w/calib	Identifies the transducer
11	XD_ERROR	RO	0	Transducer block alarm subcode
12	COLLECTION_DIRECTORY	RO	0	Directory that specifies the number & start of each transducer
13	PRIMARY_VALUE_TYPE	RO	Gauge Pressure or Absolute Pressure	Type of measurement of the primary value

Table 13. FOUNDATION Fieldbus Parameters (Continued)

Rel Index	Parameter Name	RO or R/W	Initial Factory Settings	Comments
14	PRIMARY_VALUE			
	Status	RO	GoodNonCascade, NonSpecific, NotLimited	Set by transmitter - status of measurement value
	Value	RO	0	Numerical quantity calculated by the transmitter
15	PRIMARY_VALUE_RANGE			
	EU_at_100%	R/W	per sales order <sup>(1)</sup>	The engineering units value at 100% of range
	EU_at_0%	R/W	per sales order <sup>(1)</sup>	The engineering units value at 0% of range
	Units_Index	R/W	per sales order <sup>(1)</sup>	Engineering units for the primary value
	Decimal	R/W	5 (or per S.O.)	The number of digits to the right of the decimal point
16	CAL_POINT_HI	R/W	Same as PV Range	The highest calibrated value
17	CAL_POINT_LO	R/W	Same as PV Range	The lowest calibrated value
18	CAL_MIN_SPAN	RO	per device	The minimum calibration span
19	CAL_UNIT	R/W	Same as PV Range	Engineering units during last calibration
20	SENSOR_TYPE	R/W	Strain Gauge	The type of sensor
21	SENSOR_RANGE	RO	per device	The high and low range limits of the sensor, engineering units and digits to the right of the decimal point
22	SENSOR_SN	RO	per device	The sensor serial number
23	SENSOR_CAL_METHOD	R/W	0 (none selected)	The method of last sensor calibration
24	SENSOR_CAL_LOC	R/W	Foxboro MA	The last calibration location
25	SENSOR_CAL_DATE	R/W	mm/dd/yy; hh:mm:ss	The date of the last sensor calibration
26	SENSOR_CAL_WHO	R/W	Foxboro	The name of the person responsible for the last calibration
27	SENSOR_ISOLATOR_MTL	RO	0	The material of the isolating diaphragms
28	SENSOR_FILL_FLUID	RO	0	The type of sensor fill fluid
29	SECONDARY_VALUE			
	Status	RO	Bad, OutOfService, NotLimited	Set by transmitter - status of measurement value
	Value	RO	0	Numerical quantity calculated by the transmitter or entered by the user
30	SECONDARY_VALUE_UNIT	RO	°C (or per S.O.)	The engineering unit of the secondary value
31	THIRD_VALUE			
	Status	RO	Bad, OutOfService, NotLimited	Set by transmitter - status of measurement value
	Value	RO	0	Numerical quantity calculated by the transmitter or entered by the user
32	THIRD_VALUE_RANGE			
	EU_at_100%	RO	100 (or per S.O.)	The engineering units value at 100% of range
	EU_at_0%	RO	0 (or per S.O.)	The engineering units value at 0% of range
	Units_Index	R/W	inH <sub>2</sub> O (or per S.O.)	Engineering units for the third value
	Decimal	R/W	5 (or per S.O.)	The number of digits to the right of the decimal point
33	THIRD_VALUE_TYPE	R/W	Pressure Linear	Type of measurement of the third value
34	SENSOR_DAMPING	R/W	0	The value of the sensor board M1DAMP parameter
35	FACTORY_STATUS	RO	0	Diagnostic parameter reserved for Invensys use.
36	SENSOR_STATUS	RO	0	Set by transmitter - status of the sensor.
37	TRANSDUCER_COMMAND	R/W	0	Diagnostic parameter reserved for Invensys use.
38	TRANSDUCER_RESPONSE	RO	0	Diagnostic parameter reserved for Invensys use.
39	MAU_SW_REVISION	RO	current rev	MAU firmware version
40	SB_SW_REVISION	RO	current rev	SB firmware version
41	BLOCK_ERR_DESC_1	RO	0	Details of a block error.

Table 13. FOUNDATION Fieldbus Parameters (Continued)

Rel Index	Parameter Name	RO or R/W	Initial Factory Settings	Comments
<b>Analog Input Blocks</b>				
	BLOCK_TAG	R/W	AI1(350) or AI2(400)	Unique Block ID
1	ST_REV	RO	current rev	Static data revision
2	TAG_DESC	R/W	blank	User description of the block application
3	STRATEGY	R/W	0	To ID groups of blocks
4	ALERT_KEY	R/W	0	ID number of plant unit
5	MODE_BLK			
	Target	R/W	OOS	Mode requested by operator
	Actual	RO	OOS	The current mode of the block
	Permitted	R/W	Auto, OOS, Man	Modes allowed for this block
	Normal	R/W	Auto	Mode of block during normal operations
6	BLOCK_ERR	RO	OutOfService	Error status of the hardware or software
7	PV			
	Status	RO	Bad, NonSpecific, NotLimited	The status of this block
	Value	RO	0	The value of this block
8	OUT			
	Status	RO	Bad, OutOfService, NotLimited	The status of this block
	Value	Note 2	0	The primary analog value calculated by the transmitter or entered by the user in Manual mode
9	SIMULATE			Simulates the transducer input or output to this block
	Simulate Status			
	Quality	R/W	Bad	Quality of the measurement
	Substatus	R/W	NonSpecific	Substatus
	Limits	R/W	NotLimited	Limits
	Simulate Value	R/W	0	Used for the transducer value when simulation is enabled
	Transducer Status	RO	Bad, NonSpecific, NotLimited	Set by transmitter - status of the transducer
	Transducer Value	RO	0	Current value supplied by the transducer
	Enable/Disable	R/W	Disabled	Enable/disable simulation
10	XD_SCALE			The range, units, and precision of XD_SCALE
	EU_at_100%	R/W	100	The engineering units value at 100% of range
	EU_at_0%	R/W	0	The engineering units value at 0% of range
	Units_Index	R/W	inH2O	Engineering units for the transducer value
	Decimal	R/W	5	The number of digits to the right of the decimal point
11	OUT_SCALE			The range, units, and precision of OUT_SCALE
	EU_at_100%	R/W	100	The engineering units value at 100% of range
	EU_at_0%	R/W	0	The engineering units value at 0% of range
	Units_Index	R/W	%	Engineering units for the output value
	Decimal	R/W	5	The number of digits to the right of the decimal point
12	GRANT_DENY			Options for controlling access of host computers and local control panels to operating, tuning, and alarm parameters
	Grant	R/W	0 (none selected)	
	Deny	R/W	0 (none selected)	
13	IO_OPTS	R/W	0 (none selected)	Options to alter input and output block processing
14	STATUS_OPTS	R/W	0 (none selected)	Options for block processing of status

Table 13. FOUNDATION Fieldbus Parameters (Continued)

Rel Index	Parameter Name	RO or R/W	Initial Factory Settings	Comments
15	CHANNEL	R/W	AI1 = pressure AI2 = STemp	The logical channel connected to this block - Channel 1 is pressure, Channel 2 is sensor temperature, and Channel 3 is flow
16	L_TYPE	Note 2	Indirect	Determines if value is to be used directly or converted
17	LOW_CUT	R/W	0	Not Applicable. Only used in square root processing
18	PV_FTIME	R/W	0	Time constant of a single exponential filter for the PV, in seconds.
19	FIELD_VAL			
	Status	RO	Bad, NonSpecific, NotLimited	Status of transducer condition before signal characterization or filtering
	Value	RO	0	Raw value of the field device in % of PV range
20	UPDATE_EVT	RO		Generated by any change to static data of the block
21	BLOCK_ALM	RO		For all configuration, hardware, connection failure, or system problems
22	ALARM_SUM			
	Current	RO	0	The active state of each alarm
	Unacknowledged	RO	0	The unacknowledged state of each alarm
	Unreported	RO	0	The unreported state of each alarm
	Disabled	R/W	no alarms disabled	The disabled state of each alarm
23	ACK_OPTION	R/W	no alarms auto ack'd	Selection of which alarms are automatically acknowledged
24	ALARM_HYS	R/W	0.5%	Amount the PV must return within alarm limits before the alarm condition clears
25	HI_HI_PRI	R/W	0	Priority of the High-High alarm
26	HI_HI_LIM	R/W	1.#INF	The setting for High-High alarm in engineering units
27	HI_PRI	R/W	0	Priority of the High alarm
28	HI_LIM	R/W	1.#INF	The setting for High alarm in engineering units
29	LO_PRI	R/W	0	Priority of the Low alarm
30	LO_LIM	R/W	-1.#INF	The setting for Low alarm in engineering units
31	LO_LO_PRI	R/W	0	Priority of the Low-Low alarm
32	LO_LO_LIM	R/W	-1.#INF	The setting for Low-Low alarm in engineering units
33	HI_HI_ALM	RO	0	The status of the High-High alarm
34	HI_ALM	RO	0	The status of the High alarm
35	LO_ALM	RO	0	The status of the Low alarm
36	LO_LO_ALM	RO	0	The status of the Low-Low alarm
37	BLOCK_ERR_DESC_1	RO	0	Details of a block error.
<b>PID Block</b>				
	BLOCK_TAG	R/W	PID(450)	Unique Block ID
1	ST_REV	RO	current rev	Static data revision
2	TAG_DESC	R/W	blank	User description of the block application
3	STRATEGY	R/W	0	To ID groups of blocks
4	ALERT_KEY	R/W	0	ID number of plant unit
5	MODE_BLK			
	Target	R/W	OOS	Mode requested by operator
	Actual	RO	OOS	The current mode of the block
	Permitted	R/W	Auto, Man, OOS, ROut, RCas, Cas	Modes allowed for this block
	Normal	R/W	Auto	Mode of block during normal operations
6	BLOCK_ERR	RO	Out of Service	Error status of the hardware or software

Table 13. FOUNDATION Fieldbus Parameters (Continued)

Rel Index	Parameter Name	RO or R/W	Initial Factory Settings	Comments
7	PV			
	Status	RO	Bad; NonSpecific; NotLimited	The status of this parameter
	Value	RO	0	The value of this parameter
8	SP			The value and status for this parameter
	Status	RO	Bad; OutOfService; NotLimited	The setpoint status is determined by the transmitter
	Value	Note 3	0	The setpoint value must be written even if correctly shown
9	OUT			
	Status	RO	Bad; OutOfService; NotLimited	The status of the output of this block
	Value	Note 2	0	The primary analog value calculated by the transmitter or entered by the user in Manual mode
10	PV_SCALE			The range, units, and precision of the PV parameter
	EU_at_100%	R/W	100	The engineering units value at 100% of range
	EU_at_0%	R/W	0	The engineering units value at 0% of range
	Units_Index	R/W	%	Engineering units
	Decimal	R/W	5	The number of digits to the right of the decimal point
11	OUT_SCALE			The range, units, and precision of the OUT parameter
	EU_at_100%	R/W	100	The engineering units value at 100% of range
	EU_at_0%	R/W	0	The engineering units value at 0% of range
	Units_Index	R/W	%	Engineering units
	Decimal	R/W	5	The number of digits to the right of the decimal point
12	GRANT_DENY			Options for controlling access of host computers and local control panels to operating, tuning, and alarm parameters
	Grant	R/W	0 (none selected)	
	Deny	R/W	0 (none selected)	
13	CONTROL_OPTS	R/W	0 (none selected)	Options to alter calculations in the control block
14	STATUS_OPTS	R/W	0 (none selected)	Options for block processing of status
15	IN			
	Status	Note 4	Bad; NotConnected; NotLimited	The status of this block
	Value		0	The primary input value of this block
16	PV_FTIME	R/W	0	Time constant of a single exponential filter for the PV in seconds.
17	BYPASS	R/W	0 (none selected)	Enables the normal control algorithm to be bypassed
18	CAS_IN			The remote setpoint status and value
	Status	Note 4	Bad; NotConnected; NotLimited	The status of this block
	Value		0	The value of this block
19	SP_RATE_DN	R/W	+INF	Ramp rate at which downward setpoint changes are acted upon in Auto mode
20	SP_RATE_UP	R/W	+INF	Ramp rate at which upward setpoint changes are acted upon in Auto mode
21	SP_HI_LIM	R/W	100	Setpoint high limit
22	SP_LO_LIM	R/W	0	Setpoint low limit
23	GAIN	R/W	0	Value used by the block algorithm in calculating the block output
24	RESET	R/W	+INF	Integral time constant in seconds per repeat

Table 13. FOUNDATION Fieldbus Parameters (Continued)

Rel Index	Parameter Name	RO or R/W	Initial Factory Settings	Comments
25	BAL_TIME	R/W	0	Time for internal working value of bias or ratio to return to the operator set bias or ratio in seconds
26	RATE	R/W	0	Derivative time constant in seconds
27	BKCAL_IN			Value and status from a lower block's BKCAL_OUT
	Status	Note 4	Bad; NotConnected; NotLimited	The status of this block
	Value		0	The value of this block
28	OUT_HI_LIM	R/W	100	Limits the maximum output value
29	OUT_LO_LIM	R/W	0	Limits the minimum output value
30	BKCAL_HYS	R/W	0.5	Amount the output must change away from its output limit before the limit status is turned off (in % of span of the output)
31	BKCAL_OUT			Value and status from an upper block's BKCAL_IN
	Status	RO	Bad; NonSpecific; NotLimited	The status of this block
	Value	RO	0	The value of this block
32	RCAS_IN			Target setpoint and status provided by a supervisory host to an analog control or output block
	Status	R/W	Bad; OutOfService; NotLimited	The status of this block
	Value	R/W	0	The value of this block
33	ROUT_IN			Target setpoint and status provided by a host to the control block for use as the output
	Status	R/W	Bad; OutOfService; NotLimited	The status of this block
	Value	R/W	0	The value of this block
34	SHED_OPT	R/W	0 (uninitialized)	Action to be taken on remote control device timeout
35	RCAS_OUT			Block setpoint and status after ramping
	Status	RO	Bad; NonSpecific; NotLimited	The status of this block
	Value	RO	0	The value of this block
36	ROUT_OUT			Block output and status provided to a host
	Status	RO	Bad; NonSpecific; NotLimited	The status of this block
	Value	RO	0	The value of this block
37	TRK_SCALE			The range, units, and precision associated with TRK_VALr
	EU_at_100%	R/W	100	Engineering units value at 100% of scale
	EU_at_0%	R/W	0	Engineering units value at 0% of scale
	Units_Index	R/W	%	Engineering units
	Decimal	R/W	5	The number of digits to the right of the decimal point
38	TRK_IN_D			Used to initiate external tracking of the block output to the value specified in TRK_VAL
	Status	Note 4	Bad; NotConnected; NotLimited	The status of this block
	Value		0	The value of this block
39	TRK_VAL			Input used as the track value when external tracking is enabled by TRK_IN_D
	Status	Note 4	Bad; NotConnected; NotLimited	The status of this block
	Value		0	The value of this block

Table 13. FOUNDATION Fieldbus Parameters (Continued)

Rel Index	Parameter Name	RO or R/W	Initial Factory Settings	Comments
40	FF_VAL			The feed forward status and value
	Status	Note 4	Bad; NotConnected; NotLimited	The status of this block
	Value		0	The value of this block
41	FF_SCALE			The range, units and precision of the feed forward input
	EU_at_100%	R/W	100	Engineering units value at 100% of scale
	EU_at_0%	R/W	0	Engineering units value at 0% of scale
	Units_Index	R/W	%	Engineering units
	Decimal	R/W	5	The number of digits to the right of the decimal point
42	FF_GAIN	Note 2	0	Gain that the feedforward input is multiplied by before it is added to the calculated control output
43	UPDATE_EVT	RO		Generated by any change to static data of the block
44	BLOCK_ALM	RO		For all config, hardware, connection failures, and system problems
45	ALARM_SUM			
	Current	RO	0	The active state of each alarm
	Unacknowledged	RO	0	The unacknowledged state of each alarm
	Unreported	RO	0	The unreported state of each alarm
	Disabled	R/W	no alarms disabled	The disabled state of each alarm
46	ACK_OPTION	R/W	no alarms auto ack'd	Selection of which alarms will be automatically ack'd
47	ALARM_HYS	R/W	0.5%	Amount the PV must return within alarm limits before the alarm condition clears
48	HI_HI_PRI	R/W	0	Priority of the High-High alarm (0-15)
49	HI_HI_LIM	R/W	+INF	Setting of High-High alarm in engineering units
50	HI_PRI	R/W	0	Priority of the High alarm (0-15)
51	HI_LIM	R/W	+INF	Setting of High alarm in engineering units
52	LO_PRI	R/W	0	Priority of the Low alarm (0-15)
53	LO_LIM	R/W	-INF	Setting for Low alarm in engineering units
54	LO_LO_PRI	R/W	0	Priority of the Low-Low alarm (0-15)
55	LO_LO_LIM	R/W	-INF	Setting of Low-Low alarm in engineering units
56	DV_HI_PRI	R/W	0	Priority for the high deviation alarm
57	DV_HI_LIM	R/W	+INF	Setting of high deviation alarm in engineering units
58	DV_LO_PRI	R/W	0	Priority for the low deviation alarm
59	DV_LO_LIM	R/W	-INF	Setting of low deviation alarm in engineering units
60	HI_HI_ALM	RO	0	Status and Value of the High-High alarm
61	HI_ALM	RO	0	Status and Value of the High alarm
62	LO_ALM	RO	0	Status and Value of the Low alarm
63	LO_LO_ALM	RO	0	Status and Value of the Low-Low alarm
64	DV_HI_ALM	RO	0	Status and Value of the High Deviation Alarm
65	DV_LO_ALM	RO	0	Status and Value of the Low Deviation Alarm
66	BLOCK_ERR_DESC_1	RO	0	Details of a block error.

(1) Transmitter parameters are configured as follows if calibrated range is not provided with the order:  
Span Code A: 0 to 30 inH<sub>2</sub>O; Span Code B: 0 to 200 inH<sub>2</sub>O; Span Code C: 0 to 30 psi; Span Code D: 0 to 300 psi; Span Code E: 0 to 3000 psi; Span Code F: 0 to 5000 psi.

(2) R/W only in Manual or Out of Service mode.

(3) R/W only in Auto, ROut, or Out of Service

(4) R/W only when communication link not connected.



ISSUE DATES

DEC 2001	FEB 2006
OCT 2003	OCT 2007
APR 2004	MAY 2010
FEB 2005	NOV 2013
SEP 2005	

Vertical lines to the right of text or illustrations indicate areas changed at last issue date.



Invensys 10900 Equity Drive Houston, TX 77041 United States of America <a href="http://www.invensys.com">http://www.invensys.com</a>  Global Customer Support Inside U.S.: 1-866-746-6477 Outside U.S.: 1-508-549-2424 or contact your local Invensys representative. Website: <a href="http://support.ips.invensys.com">http://support.ips.invensys.com</a>		
--	--	--

Invensys, Foxboro, and I/A Series are trademarks of Invensys plc, its subsidiaries, and affiliates. All other brand names may be trademarks of their respective owners.

Copyright 2001-2013 Invensys Systems, Inc. All rights reserved