

**I/A Series[®] Digital Coriolis Mass Flow Transmitter
Model CFT51**

Safety Connection Diagrams (FM, CSA)



Contents

Figures.....	v
Safety Connection Diagrams	1
FM Approvals	1
Flowtube and Transmitter in Class I, Division 2 (Non-Incendive)	1
Flowtube in Class I, Division 1 (Intrinsic Safety); Transmitter in Class I, Division 2 (Non-Incendive)	3
Flowtube in Class I, Division 2 (Non-Incendive); Transmitter in Class I, Division 1 (Explosionproof)	5
Flowtube in Class I, Division 1 (Intrinsic Safety); Transmitter in Class I, Division 1 (Explosionproof)	7
CSA International	9
Flowtube and Transmitter in Class I, Division 2 (Non-Incendive)	9
Flowtube in Class I, Division 1 (Intrinsic Safety); Transmitter in Class I, Division 2 (Non-Incendive)	11
Flowtube in Class I, Division 1 (Intrinsic Safety); Transmitter in Class I, Division 1 (Explosionproof)	13

Figures

- 1 Flowtube and Transmitter Located in Class I, Division 2 (Non-Incendive) Area..... 2
- 2 Flowtube in Class I, Division 1 (Intrinsic Safety) and Transmitter in Class I, Division 2
(Non-Incendive) Area 4
- 3 Flowtube in Class I, Division 2 (Non-Incendive) and Transmitter in Class I, Division 1
(Explosionproof) Area 6
- 4 Flowtube in Class I, Division 1 (Intrinsic Safety) and Transmitter in Class I, Division 1
(Explosionproof) Area 8
- 5 Flowtube and Transmitter Located in Class I, Division 2 (Non-Incendive) Area..... 10
- 6 Flowtube in Class I, Division 1 (Intrinsic Safety) and Transmitter in Class I, Division 2
(Non-Incendive) Area 12
- 7 Flowtube in Class I, Division 1 (Intrinsic Safety) and Transmitter in Class I, Division 1
(Explosionproof) Area 14

Safety Connection Diagrams

Connect your CFT51 Transmitter per the following diagrams for the appropriate agency.

FM Approvals

Flowtube and Transmitter in Class I, Division 2 (Non-Incendive)

— **! WARNING** —

These products must be installed to meet all applicable local installation regulations such as hazardous location requirements, electrical wiring codes, and mechanical piping codes. Persons involved in the installation must be trained in these code requirements to ensure that the installation takes maximum advantage of the safety features designed into the transmitter.

— **! WARNING** —

To prevent ignition of flammable or combustible atmospheres, disconnect power before servicing.

— **! WARNING** —

To prevent ignition of flammable or combustible atmospheres, read, understand and adhere to the manufacturer’s live maintenance procedures.

— **! WARNING** —

Explosion hazard substitution of components may impair suitability for Class I, Division 2.

— **NOTE** —

1. Figure 1 must not be revised without prior FM approval.
2. Dust-tight conduit seal must be used when installed in Class II and Class III environments.

FM Approvals CFT51 Transmitters and CFS Series Flowtube in Class I Division 2 (NI) Area

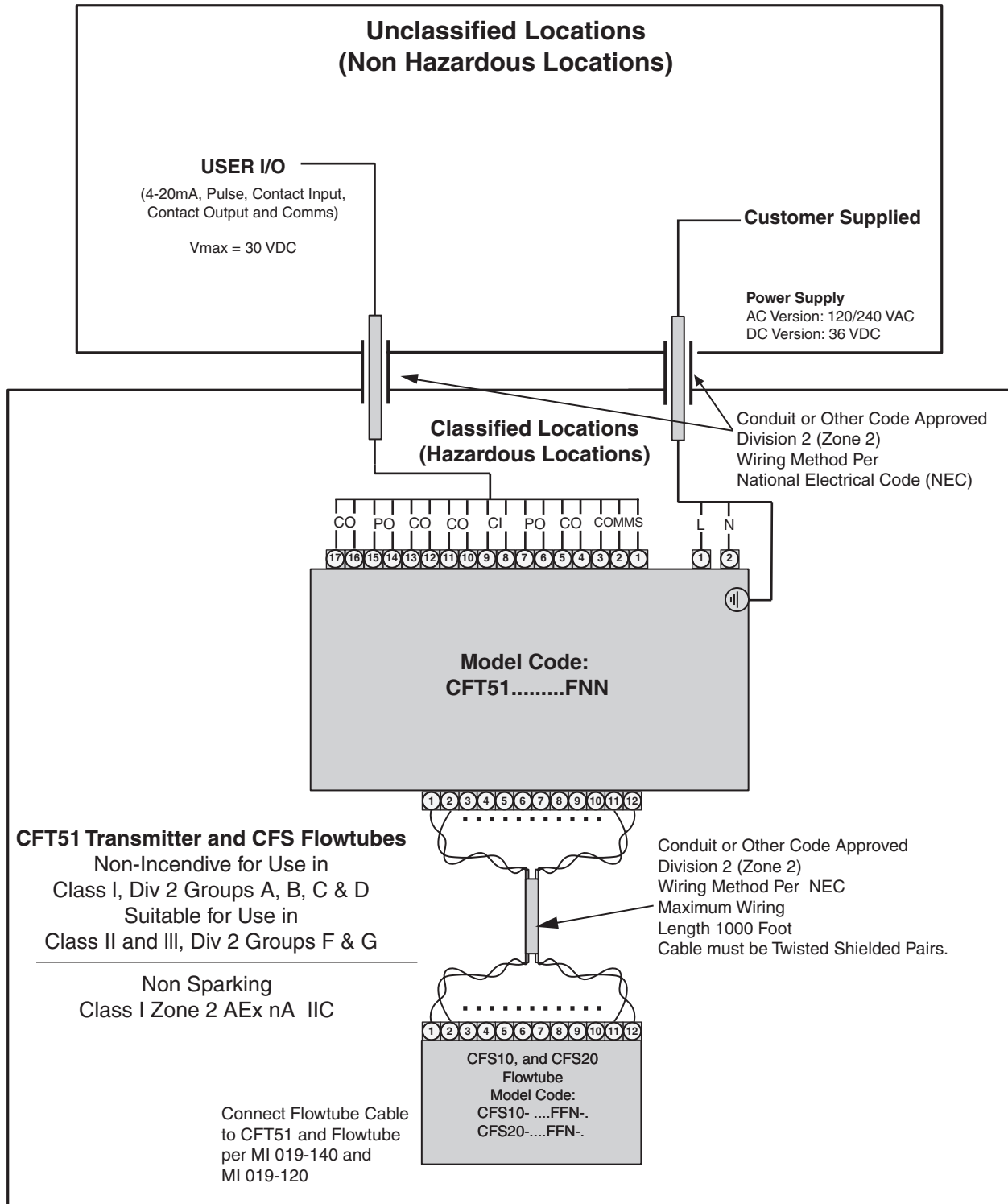

Figure 1. Flowtube and Transmitter Located in Class I, Division 2 (Non-Incendive) Area

Flowtube in Class I, Division 1 (Intrinsic Safety); Transmitter in Class I, Division 2 (Non-Incendive)

—  **WARNING** —

These products must be installed to meet all applicable local installation regulations such as hazardous location requirements, electrical wiring codes, and mechanical piping codes. Persons involved in the installation must be trained in these code requirements to ensure that the installation takes maximum advantage of the safety features designed into the transmitter.

—  **WARNING** —

To prevent ignition of flammable or combustible atmospheres, disconnect power before servicing.

—  **WARNING** —

To prevent ignition of flammable or combustible atmospheres, read, understand and adhere to the manufacturer's live maintenance procedures.

—  **WARNING** —

Explosion hazard substitution of components may impair suitability for Class I, Division 2 or intrinsic safety.

— **NOTE** —

1. Figure 2 must not be revised without prior FM approval.
 2. Dust-tight conduit seal must be used when installed in Class II and Class III environments.
 3. Installation should be in accordance with ANSI/ISA RP12.06.01 "Installation of Intrinsically Safe Systems for Hazardous (Classified) Locations" and the National Electrical Code (ANSI/NFPA 70).
 4. The I.S. ground terminal on the housing must be connected back to a suitable ground electrode per NFPA 70, article 504; the resistance of the ground path must be less than 1 ohm and the earth ground terminal on the housing must be connected to earth ground. Both ground wires must be connected at all times and must not be removed.
-

FM Approvals
CFT51 Transmitters in Class I Division 2 (NI) Area
with
CFS Series Flowtube in Class I Division 1 (IS) Area

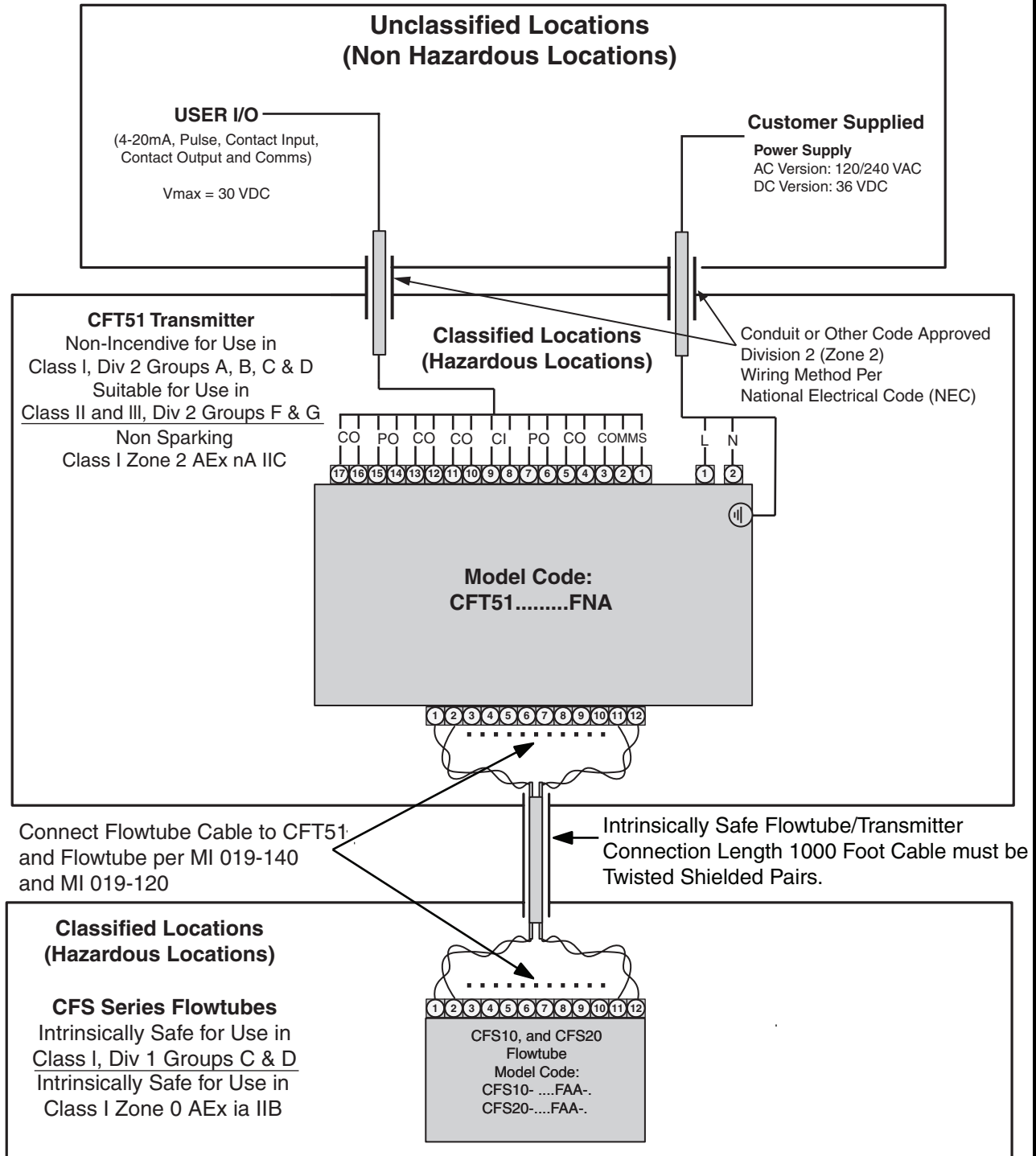

Figure 2. Flowtube in Class I, Division 1 (Intrinsic Safety) and Transmitter in Class I, Division 2 (Non-Incendive) Area

Flowtube in Class I, Division 2 (Non-Incendive); Transmitter in Class I, Division 1 (Explosionproof)

— **! WARNING** —

These products must be installed to meet all applicable local installation regulations such as hazardous location requirements, electrical wiring codes, and mechanical piping codes. Persons involved in the installation must be trained in these code requirements to ensure that the installation takes maximum advantage of the safety features designed into the transmitter.

— **! WARNING** —

To prevent ignition of flammable or combustible atmospheres, disconnect power before servicing.

— **! WARNING** —

To prevent ignition of flammable or combustible atmospheres, read, understand and adhere to the manufacturer's live maintenance procedures.

— **! WARNING** —

Substitution of components may impair suitability for Class I, Division 2.

— **NOTE** —

1. Figure 3 must not be revised without prior FM approval.
 2. Dust-tight conduit seal must be used when installed in Class II and Class III environments.
 3. For gas group A, a conduit seal is required at the conduit entries.
 4. All conduits must be assembled with a minimum of five full threads engagement.
-

**FM Approvals
CFT51 Transmitters in Class I Division 1 (XP) Area
with
CFS Series Flowtube in Class I Division 2 (NI) Area**

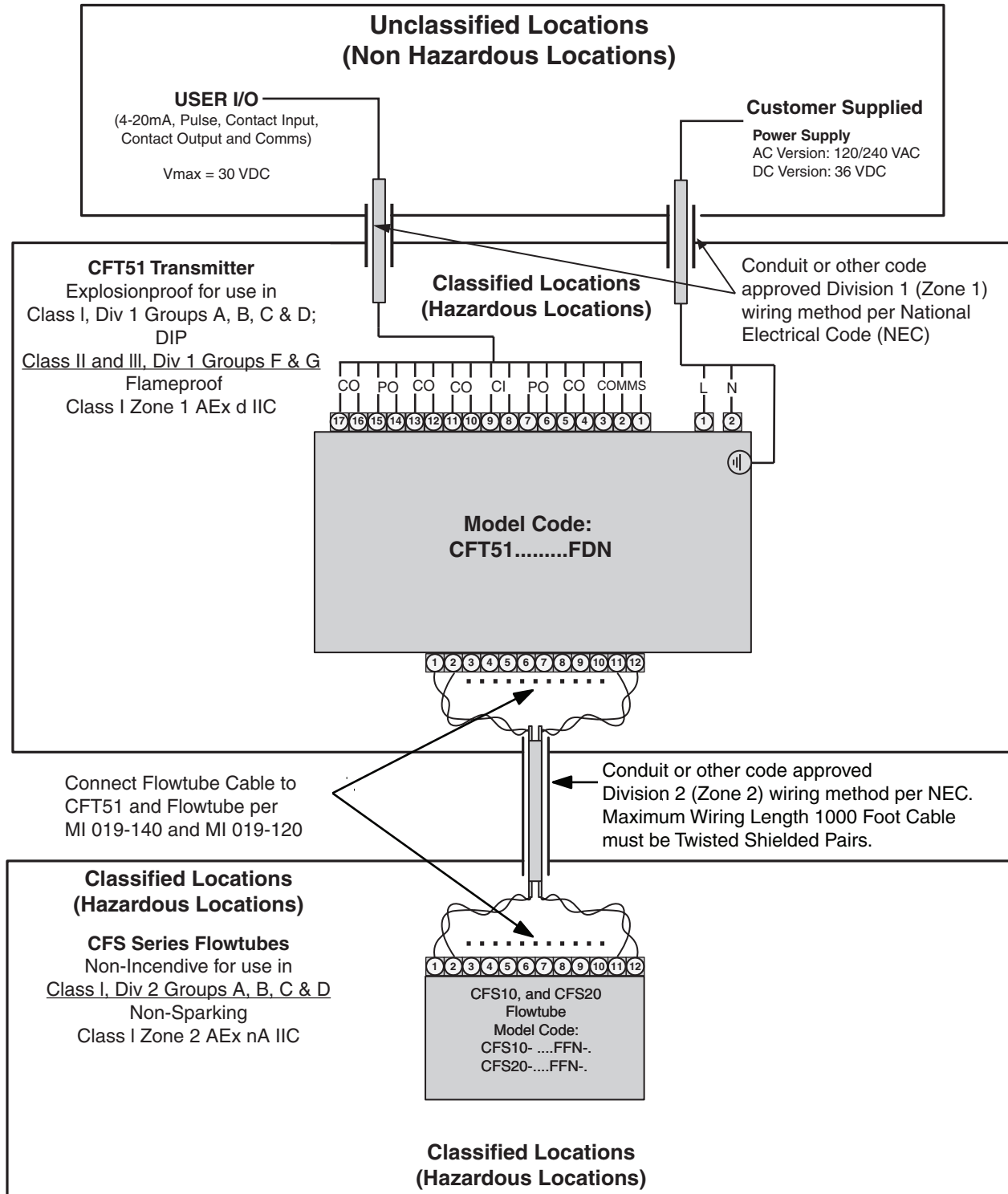

Figure 3. Flowtube in Class I, Division 2 (Non-Incendive) and Transmitter in Class I, Division 1 (Explosionproof) Area

Flowtube in Class I, Division 1 (Intrinsic Safety); Transmitter in Class I, Division 1 (Explosionproof)

— **! WARNING** —

These products must be installed to meet all applicable local installation regulations such as hazardous location requirements, electrical wiring codes, and mechanical piping codes. Persons involved in the installation must be trained in these code requirements to ensure that the installation takes maximum advantage of the safety features designed into the transmitter.

— **! WARNING** —

To prevent ignition of flammable or combustible atmospheres, disconnect power before servicing.

— **! WARNING** —

To prevent ignition of flammable or combustible atmospheres, read, understand and adhere to the manufacturer's live maintenance procedures.

— **! WARNING** —

Substitution of components may impair intrinsic safety.

— **NOTE** —

1. Figure 4 must not be revised without prior FM approval.
 2. The associated apparatus manufacturer's installation drawing must be followed when installing this equipment.
 3. Dust-tight conduit seal must be used when installed in Class II and Class III environments.
 4. Installation should be in accordance with ANSI/ISA RP12.06.01 "Installation of Intrinsically Safe Systems for Hazardous (Classified) Locations" and the National Electrical Code (ANSI/NFPA 70).
 5. The I.S. ground terminal on the housing must be connected back to a suitable ground electrode per NFPA 70, article 504; the resistance of the ground path must be less than 1 ohm and the earth ground terminal on the housing must be connected to earth ground. Both ground wires must be connected at all times and must not be removed.
 6. For gas group A, a conduit seal is required at the conduit entries.
 7. All conduits must be assembled with a minimum of five full threads engagement.
-

**FM Approvals
CFT51 Transmitters in Class I Division 1 (XP) Area
with
CFS Series Flowtube in Class I Division 1 (IS) Area**

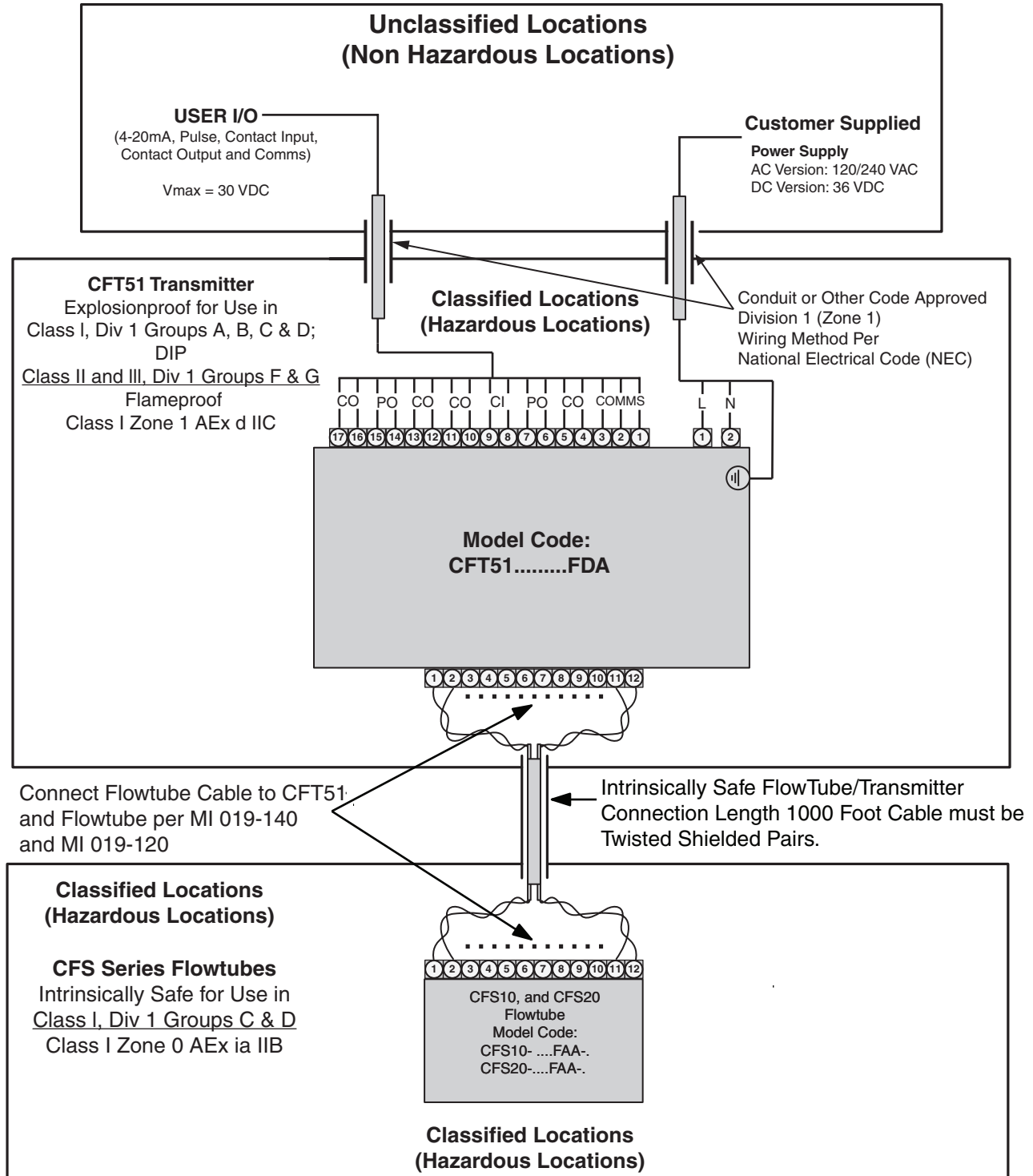

Figure 4. Flowtube in Class I, Division 1 (Intrinsic Safety) and Transmitter in Class I, Division 1 (Explosionproof) Area

CSA International

Flowtube and Transmitter in Class I, Division 2 (Non-Incendive)

— **! WARNING** —

These products must be installed to meet all applicable local installation regulations such as hazardous location requirements, electrical wiring codes, and mechanical piping codes. Persons involved in the installation must be trained in these code requirements to ensure that the installation takes maximum advantage of the safety features designed into the transmitter.

— **! WARNING** —

Explosion hazard - Do not disconnect equipment unless power has been turned off or the area is known to be non-hazardous.

— **! WARNING** —

Do not open unless area is known to be non-hazardous.

— **! WARNING** —

To prevent ignition of flammable or combustible atmospheres, disconnect power before removing covers and servicing.

— **! WARNING** —

To prevent ignition of flammable or combustible atmospheres, read, understand and adhere to the manufacturer's live maintenance procedures.

— **! WARNING** —

Explosion hazard substitution of components may impair suitability for Class I, Division 2 / Zone 2 or intrinsic safety.

— **NOTE** —

1. Figure 5 must not be revised without prior CSA approval.
 2. Dust-tight conduit seal must be used when installed in Class II and Class III environments.
 3. All conduits must be assembled with a minimum of five full threads engagement and thread lubricant applied. Only Fiske Brothers L0113-001 AERO (Invensys Part Number X0114AT) lubricant is allowed.
-

CSA International CFT51 Transmitters and CFS Series Flowtube in Class I Division 2 (NI) Area

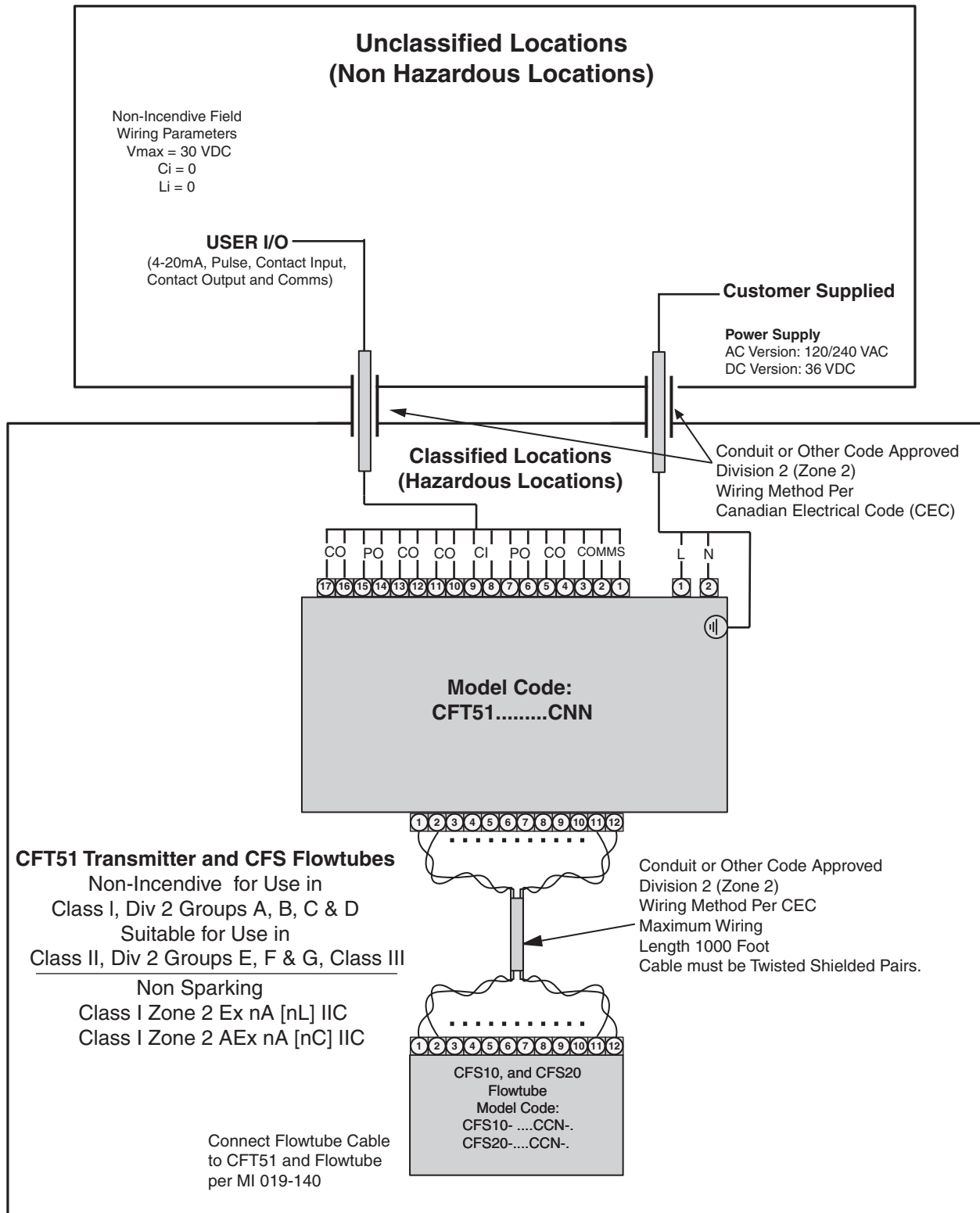

Figure 5. Flowtube and Transmitter Located in Class I, Division 2 (Non-Incendive) Area

Flowtube in Class I, Division 1 (Intrinsic Safety); Transmitter in Class I, Division 2 (Non-Incendive)

— **! WARNING** —

These products must be installed to meet all applicable local installation regulations such as hazardous location requirements, electrical wiring codes, and mechanical piping codes. Persons involved in the installation must be trained in these code requirements to ensure that the installation takes maximum advantage of the safety features designed into the transmitter.

— **! WARNING** —

Explosion hazard - do not disconnect equipment unless power has been turned off or the area is known to be non-hazardous.

— **! WARNING** —

Do not open unless area is known to be non-hazardous.

— **! WARNING** —

To prevent ignition of flammable or combustible atmospheres, disconnect power before removing covers and servicing.

— **! WARNING** —

To prevent ignition of flammable or combustible atmospheres, read, understand and adhere to the manufacturer's live maintenance procedures.

— **! WARNING** —

Explosion hazard substitution of components may impair suitability for Class I, Division 2 / Zone 2 or intrinsic safety.

— **NOTE** —

1. Figure 6 must not be revised without prior CSA approval.
 2. Dust-tight conduit seal must be used when installed in Class II and Class III environments.
 3. Install in accordance with the Canadian electrical code (part 1).
 4. The I.S. ground terminal on the housing must be connected back to a suitable ground electrode per CEC; the resistance of the ground path must be less than 1 ohm and the earth ground terminal on the housing must be connected to earth ground. Both ground wires must be connected at all times and must not be removed.
 5. All conduits must be assembled with a minimum of five full threads engagement and thread lubricant applied. Only Fiske Brothers L0113-001 AERO (Invensys Part Number X0114AT) lubricant is allowed.
-

**CSA International
CFT51 Transmitters in Class I Division 2 (NI) Area
with
CFS Series Flowtube in Class I Division 1 (IS) Area**

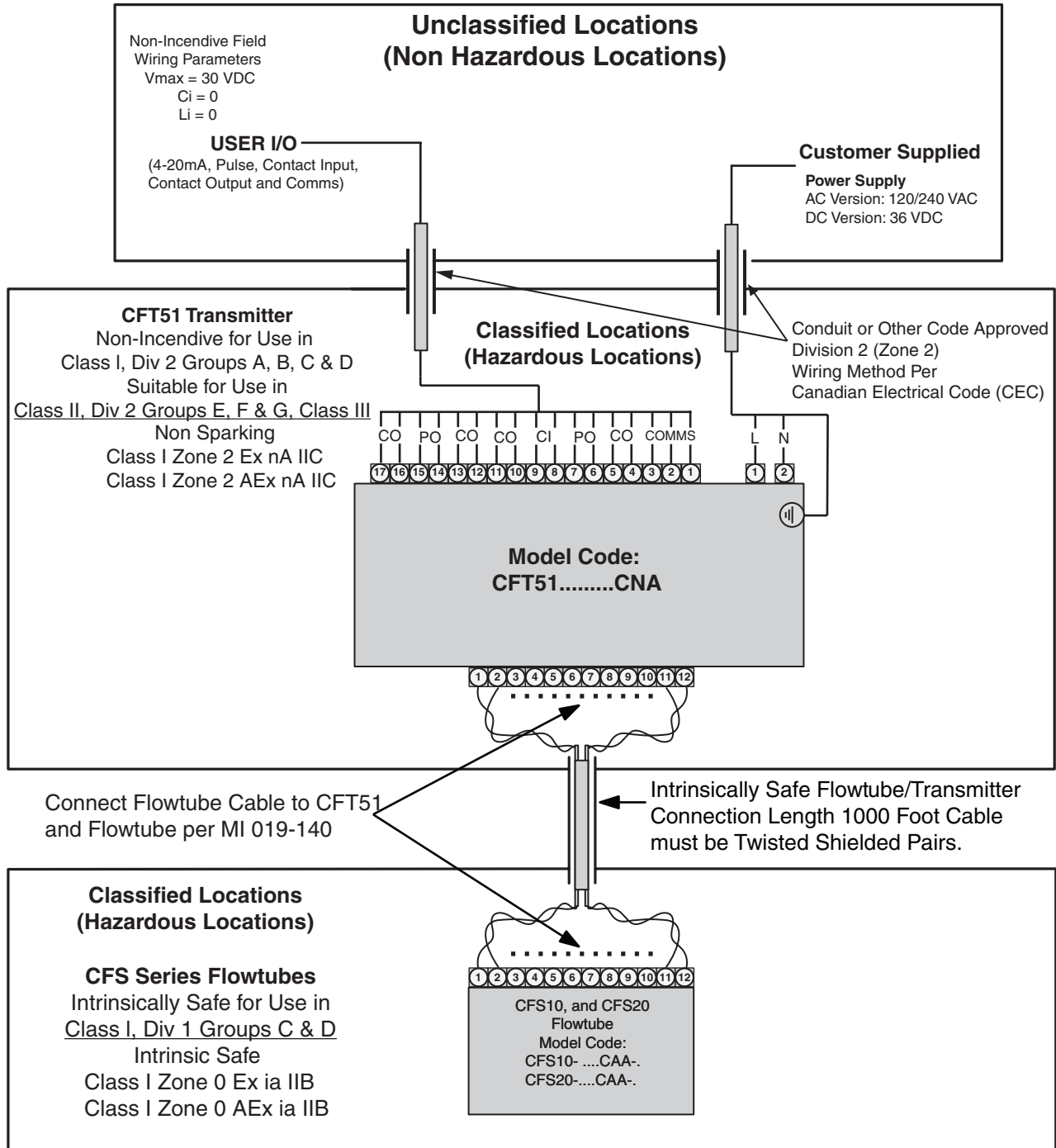

Figure 6. Flowtube in Class I, Division 1 (Intrinsic Safety) and Transmitter in Class I, Division 2 (Non-Incendive) Area

Flowtube in Class I, Division 1 (Intrinsic Safety); Transmitter in Class I, Division 1 (Explosionproof)

— **! WARNING** —

These products must be installed to meet all applicable local installation regulations such as hazardous location requirements, electrical wiring codes, and mechanical piping codes. Persons involved in the installation must be trained in these code requirements to ensure that the installation takes maximum advantage of the safety features designed into the transmitter.

— **! WARNING** —

Explosion hazard - do not disconnect equipment unless power has been turned off or the area is known to be non-hazardous.

— **! WARNING** —

Do not open unless area is known to be non-hazardous.

— **! WARNING** —

To prevent ignition of flammable or combustible atmospheres, disconnect power before removing covers and servicing.

— **! WARNING** —

To prevent ignition of flammable or combustible atmospheres, read, understand and adhere to the manufacturer's live maintenance procedures.

— **! WARNING** —

Substitution of components may impair intrinsic safety.

— **NOTE** —

1. Figure 7 must not be revised without prior CSA approval.
 2. The associated apparatus manufacturer's installation drawing must be followed when installing this equipment.
 3. Dust-tight conduit seal must be used when installed in Class II and Class III environments.
 4. Install in accordance with the Canadian electrical code (part 1).
 5. The I.S. ground terminal on the housing must be connected back to a suitable ground electrode per CEC; the resistance of the ground path must be less than 1 ohm and the earth ground terminal on the housing must be connected to earth ground. Both ground wires must be connected at all times and must not be removed.
 6. For gas group A, a conduit seal is required at the conduit entries.
 7. All conduits must be assembled with a minimum of five full threads engagement and thread lubricant applied. Only Fiske Brothers L0113-001 AERO (Invensys Part Number X0114AT) lubricant is allowed.
-

**CSA International
CFT51 Transmitters in Class I Division 1 (XP) Area
with
CFS Series Flowtube in Class I Division 1 (IS) Area**

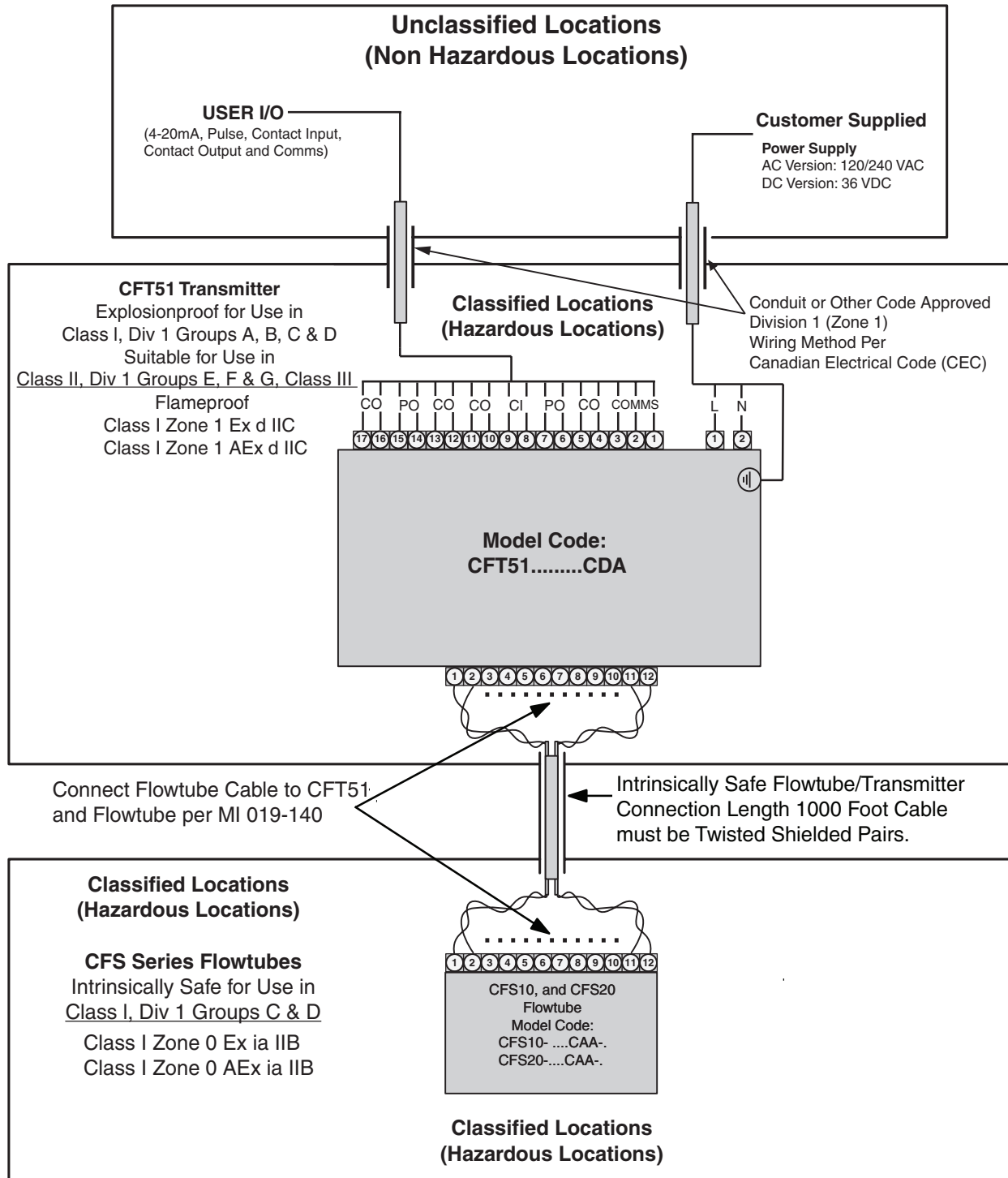

Figure 7. Flowtube in Class I, Division 1 (Intrinsic Safety) and Transmitter in Class I, Division 1 (Explosionproof) Area

ISSUE DATES

JUN 2011

NOV 2012

Vertical lines to the right of text or illustrations indicate areas changed at last issue date.

Invensys Operations Management
5601 Granite Parkway Suite 1000
Plano, TX 75024
United States of America
<http://www.iom.invensys.com>

Global Customer Support
Inside U.S.: 1-866-746-6477
Outside U.S.: 1-508-549-2424 or contact
your local Invensys representative.
Website: <http://support.ips.invensys.com>

Invensys, Foxboro, and I/A Series are trademarks of
Invensys plc, its subsidiaries, and affiliates.
All other brand names may be trademarks of their
respective owners.

Copyright 2011-2012 Invensys Systems, Inc.
All rights reserved