



**Instruction**

MI 021-138  
November 1995

## **Magnetic Flow System**

**2800 Series Flowtubes with an 896 or an E96 Transmitter**

**Fault Location Guide**



A Siebe Group Company



# Contents

<b>Figures</b> .....	<b>v</b>
<b>Tables</b> .....	<b>vi</b>
Introduction .....	1
Reference Instructions .....	1
Typical Transmitter and Flowtube Installation .....	3
Fluid Conductivity and Cabling .....	3
With the E96 Transmitter (ac) .....	3
With the 896 Transmitter (Pulsed dc) .....	5
Fault Location Table .....	5
2800 Flowtube Component Locations .....	13
Terminal Connections .....	13
2800 Flowtube Terminal Connections .....	13
896 Transmitter Terminal Connections .....	14
E96P, E96S, and E96T Transmitters, Style D, Terminal Connections .....	14
E96R Transmitter, Style D, Terminal Connections .....	15
E96P, E96S, and E96T Transmitters, Styles A, B, and C, Terminal Connections .....	15
E96R Transmitter, Styles A, B, and C, Terminal Connections .....	16



# Figures

- 1 Typical Transmitter and Flowtube Installations ..... 3
- 2 Maximum Allowable Cable Length for Standard System Accuracy  
with the E96 Transmitter ..... 4
- 3 2800 Flowtube Component Locations ..... 13
- 4 2800 Flowtube Terminal Connections ..... 13
- 5 896 Transmitter Terminal Connections ..... 14
- 6 E96P, E96S, and E96T, Style D, Transmitter Terminal Connections ..... 14
- 7 E96R Transmitter, Style D, Terminal Connections ..... 15
- 8 E96P, E96S, and E96T Transmitters, Styles A, B, and C, Terminal Connections ..... 15
- 9 E96R Transmitter, Styles A, B, and C, Terminal Connections ..... 16

# *Tables*

1	Symptoms, Probable Causes and Solutions .....	6
---	---	---

# Introduction

The combining of an 896 (pulsed dc) or E96 (ac) Magnetic Flow Transmitter with a 2800 Series Magnetic Flowtube results in a Magnetic Flow System. Since the flowtube and transmitter operate as a unit, faulty operation of one can be caused by a defect or misadjustment in the other.

The following procedures assume that proper installation guidelines have been implemented. However, items such as conductivity below published limits for installed cable length, installation wiring, defects in adequate earthing (grounding), improper piping practices, entrained air, and partially filled flowtube may affect performance.

Solution sequence in this guide is by convenience, not necessarily by probability. Fault locations described in this instruction pertain only to the transmitter with analog output.

Before proceeding with system fault location, check that the external receivers are not faulty. This can be done by disconnecting the external receivers and monitoring the output of the transmitter with a milliammeter. This will also isolate the problem to either the flow system, external receivers, or optional features.

## Reference Instructions

### **FLOWTUBE**

MI 021-120	Lined Metal Sizes 15 to 300 mm (1/2 to 12 in) Flowtubes
MI 021-136	Lined Metal Sizes 350 to 900 mm (14 to 36 in) Flowtubes, Style B
MI 021-137	Lined Metal Sizes 350 to 900 mm (14 to 36 in) Flowtubes, Style C
MI 021-141	Sanitary Sizes 15 to 80 mm (1/2 to 3 in) Flowtubes
MI 021-145	Division 1 Construction Flowtube
MI 021-150	Submersible Construction Flowtube
MI 021-181	Replaceable Metering Tube
MI 021-185	Nulling Procedure for Flowtube
MI 021-191	Cabling Flowtube to E96 Transmitter, Styles A, B, and C
MI 021-240	Ultrasonic Electrode Cleaning Option for Flowtube

### **E96 TRANSMITTER, STYLES A, B, AND C**

MI 021-311	E96T Transmitter, Styles A, B, and C; Installation and Operation
MI 021-312	E96P and S Transmitter, Styles A, B, and C; Installation and Operation
MI 021-313	E96R Transmitter, Styles A, B, and C; Installation and Operation
MI 021-315	E96 Transmitter, Styles A and B, and PTB, Versions Styles A, B, and C; Servicing
MI 021-316	E96 Transmitter, Style C; Servicing
MI 021-320	E96 Transmitter, Styles A, B, and C; Low Pulse Rate Option
MI 021-325	E96 Transmitter, Styles A, B, and C; High Pulse Rate Option
MI 021-328	E96 Transmitter, Styles A, B, and C; CYCLE LOGIC Pulse Rate Option

**E96 TRANSMITTER, STYLE D**

MI 021-333	E96P and S Transmitter, Style D; Installation and Operation
MI 021-334	E96R Transmitter, Style D; Installation and Operation
MI 021-335	E96T Transmitter, Style D; Installation and Operation
MI 021-336	E96 Transmitter, Style D; Servicing
MI 021-337	E96 Transmitter, Style D; Low-Rate Pulse Option
MI 021-338	E96 Transmitter, Style D; High-Rate Pulse Option
MI 021-339	E96 Transmitter, Style D; Switch Closure Option
MI 021-340	E96 Transmitter, Style D; Span Switch Option

**896 TRANSMITTER**

MI 021-350	896P and 896S Transmitter; Installation and Operation
MI 021-351	896T Transmitter; Installation and Operation
MI 021-352	896 Transmitter; Servicing
MI 021-354	896 Transmitter; Adjustable 0.1 to 10 Hz Pulse Output Option
MI 021-355	896 Transmitter; 0 to 2000 Hz Unscaled Pulse Output Option
MI 021-356	896 Transmitter; Adjustable Switch Closure Pulse Output Option
MI 021-357	896 Transmitter; Span Switch Option
MI 021-358	896 Transmitter; Digital Rate Meter Option

**CALIBRATORS**

MI 021-200	8120 Calibrator, Style B (used to calibrate E96 Transmitter)
MI 021-349	896CAL Field Calibrator (used to calibrate 896 Transmitter)

# Typical Transmitter and Flowtube Installation

Refer to Figure 1 for typical installation of an E96 or an 896 Transmitter with a 2800 Series Flowtube. Remote mounted, panel mounted, and integrally mounted transmitters are shown.

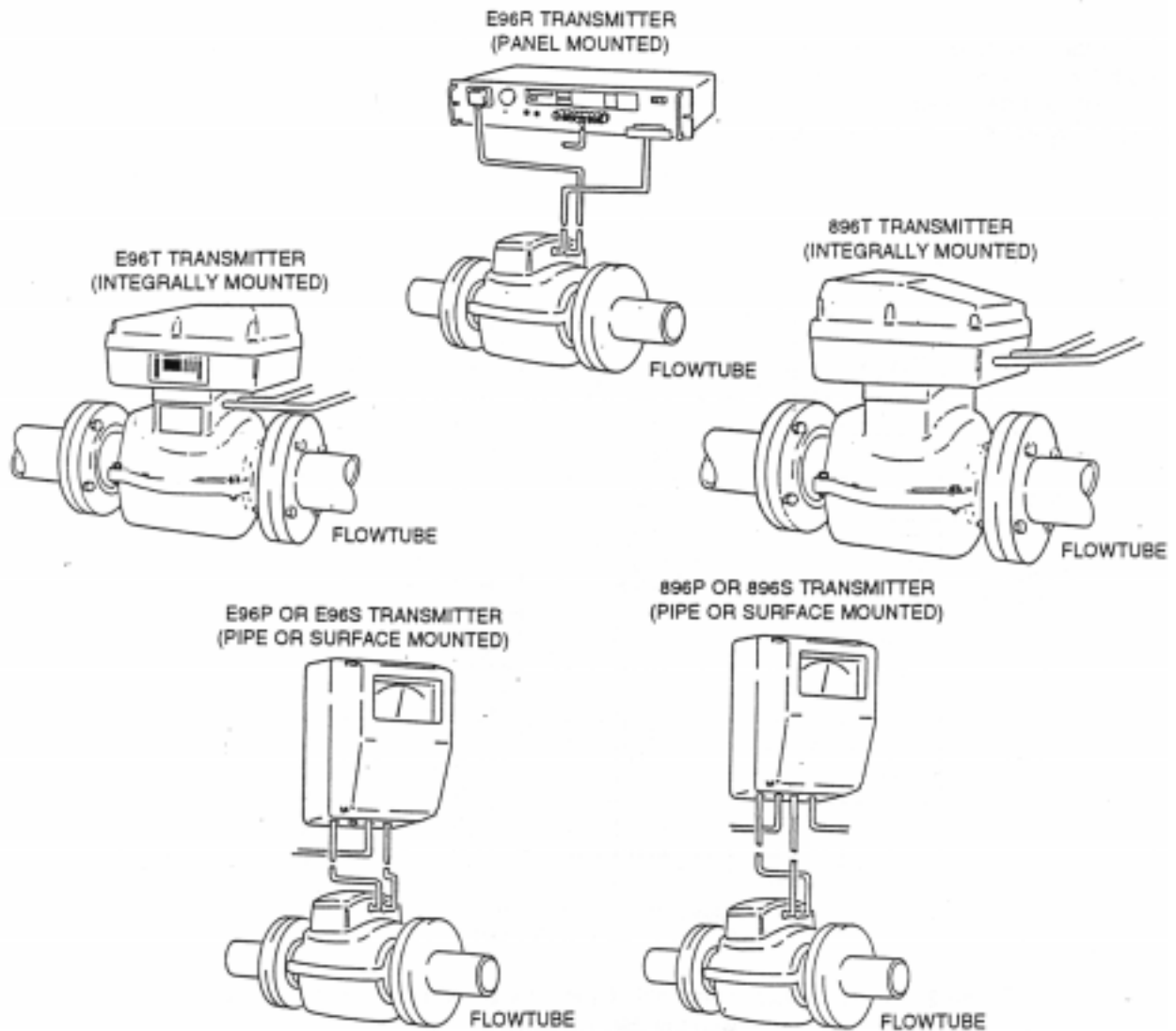

**Figure 1. Typical Transmitter and Flowtube Installations**

## Fluid Conductivity and Cabling

### With the E96 Transmitter (ac)

Figure 2 relates conductivity, flowtube size, and permissible signal cable length between flowtube and the E96 Transmitter. It is valid only for cable recommended by and available from Foxboro, with driven screens (shields) electrically connected. The graph is used to determine:

1. Maximum cable length for specified system performance for given conductivity and flowtube size, or

2. Minimum conductivity required for specified system performance for a given cable length and flowtube size.

**Example:**

To find the maximum permissible signal cable length for a 40 mm (1 1/2 in) flowtube to be used with an E96 Transmitter with a fluid conductivity of 5500  $\mu\text{S/m}$  (55  $\mu\text{mho/cm}$ ).

Refer to dotted lines in Figure 2.

- a. Draw a vertical line at a fluid conductivity of 5300  $\mu\text{S/m}$  intersecting the 15 to 40 mm (1/2 to 1 1/2 in) reference line.
- b. From this intersection, draw a horizontal line to the transmitter standard performance line.
- c. From this intersection, draw a vertical line to the cable length scale where approximately 40 m (130 ft) is read.

*NOTE: The graph can be used to solve the above problem in reverse, using a desired cable length of 40 m (130 ft) with a 40 mm (1 1/2 in) flowtube to determine minimum conductivity of 5500  $\mu\text{S/m}$  (55  $\mu\text{mho/cm}$ ) at specified accuracy.*

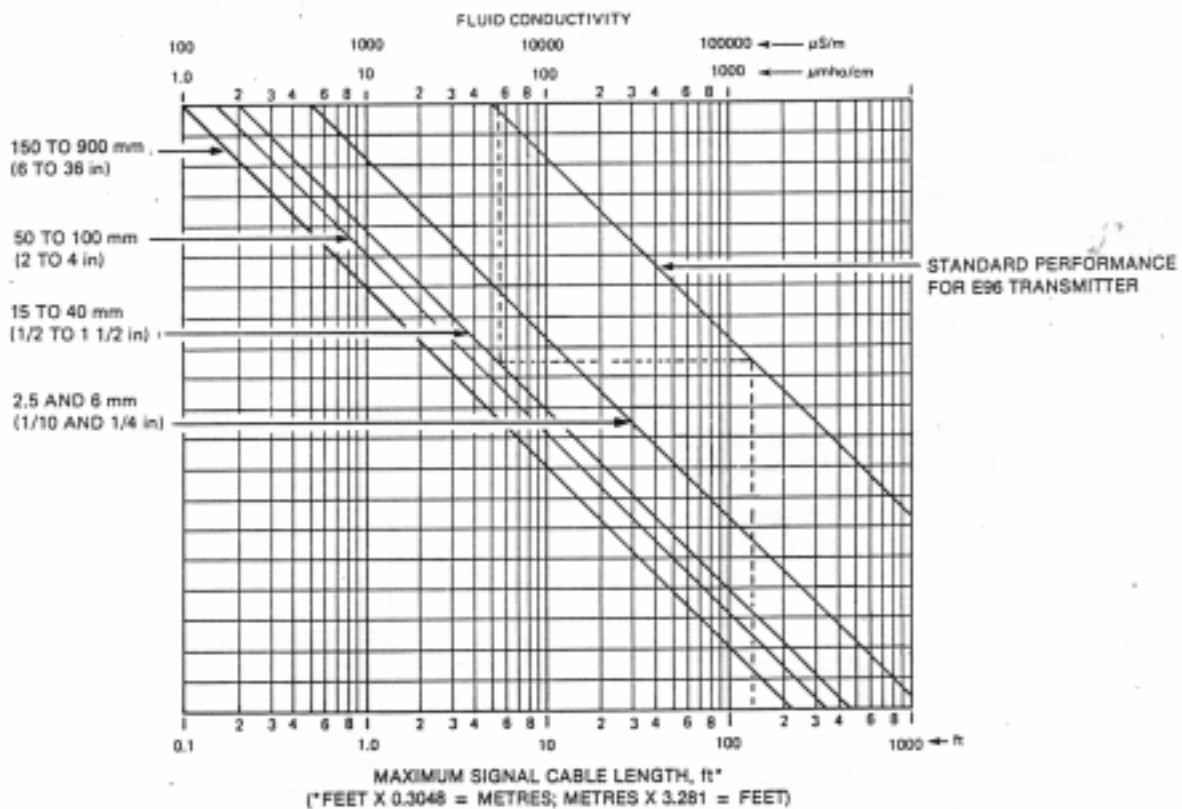

**Figure 2. Maximum Allowable Cable Length for Standard System Accuracy with the E96 Transmitter**

## With the 896 Transmitter (Pulsed dc)

The maximum allowable cable length is a function of the cable type, process fluid conductivity, and whether the cables are in the same or separate conduits. Standard system accuracy will be maintained when the installations (flowtube and 896 Transmitter) are in accordance with the table below.

Maximum Cable Length		Minimum Fluid Conductivity	Signal and Coil Driver Cable Description	
m	ft		Signal Cable	Driver Cable
300	1000	5 $\mu$ S/cm	Signal cable to be Foxboro Part No. R0101ZS. Signal cable to be in separate conduit.	Driver cable consists of two 2.5 mm <sup>2</sup> or 14 AWG wires. Driver cable to be in separate conduit.
225	750	5 $\mu$ S/cm	Signal cable to be Foxboro Part No. R0101ZS. Signal cable to be in same conduit as driver cable.	Driver cable consists of two 2.5 mm <sup>2</sup> or 14 AWG wires. Driver cable to be in same conduit as signal cable.
150	500	20 $\mu$ S/cm	Signal cable to be good quality twisted shielded pair, preferably no smaller than 1.0 mm <sup>2</sup> or 18 AWG for mechanical considerations. Signal cable may be in same conduit as driver cable.	Driver cable consists of two 2.5 mm <sup>2</sup> or 14 AWG wires. Driver cable to be in same conduit as signal cable.

\*Belden 8760 or 9318, Alpha 5610/1801 or 5611/1801, or equivalent.

## Fault Location Table

To use Table 1, find the symptom in the following list and go to the page specified next to the symptom. Select the applicable solution from the table.

Symptom Number and Description	Location
1. No Output	Table 1, page 6
2. No Output (Zero mA)	Table 1, page 6
3. Output is Constantly Half or Twice Correct Value	Table 1, page 6
4. Measurement Reads Low with Flow	Table 1, page 7
5. Measurement Reads High with Flow	Table 1, page 9
6. Erratic Flow Signal	Table 1, page 10
7. Drifting Flow Signal	Table 1, page 10
8. Cannot Obtain Correct Zero Reading	Table 1, page 11
9. Measurement Reads Below Zero with Flow	Table 1, page 12

**Table 1. Symptoms, Probable Causes and Solutions**

Symptoms and Probable Cause	Solution
<p><b>1. No Output (Zero mA)</b></p> <p>a. No ac supply to flowtube or E96 Transmitter.</p> <p>b. No ac supply to 896 Transmitter.</p> <p>c. For system with E96 Styles A, B, or C or 896 Transmitter: blown fuse(s).</p>	<p>a. Apply ac supply voltage.</p> <p>b. Apply ac supply voltage.</p> <p>c. Install new fuse(s). For E96, see Figure 8; for 896, see Figure 5.</p>
<p><b>2. No Output (Constant 4 mA)</b></p> <p>a. Jumpers not correctly positioned on flowtube coil terminals.</p> <p>b. Transmitter input signal cable miswired or shorted.</p> <p>c. Open coil with series-wired flowtube coils.</p>	<p>a. Put jumpers in correct position. See Figure 4.</p> <p>b. Check wiring per instructions. Measure resistance between terminals. If less than 1 <math>\Omega</math>, a short is indicated. Locate and repair short.</p> <p>c. Check resistance between terminals 1 and B. Repeat test between 2 and A. If open indicated, replace coil.</p>
<p><b>3. Output is Constantly Half or Twice Correct Value</b></p> <p>a. Miswired (series vs. parallel) coil connection.</p> <p>b. Line voltage 120 V ac instead of 240 V ac, or vice versa.</p> <p>c. Incorrect calibration factor used for E96 or 896.</p> <p>d. Transmitter not properly calibrated.</p> <p>e. Shorted electrode.</p> <p>f. One coil shorted (series wired), or one coil open (parallel wired).</p>	<p>a. Check that coils are wired as indicated on flowtube data plate. Refer to Figure 4.</p> <p>b. Verify supply voltage as designated on flowtube and transmitter data plate.</p> <p>c. Check for correct factor for ac or pulsed dc transmitter. Nominal ac/dc factors are listed in flowtube instruction.</p> <p>d. Check transmitter calibration. Verify correct mV setting on calibrator dial for range switch position selected.</p> <p>e. Under normal operating process conditions, short black electrode wire to inner screen. If no change is observed on output, electrode may be shorted. Repeat test with white electrode wire to inner screen. If shorted, consult Foxboro.</p> <p>f. Shut off power. Disconnect jumpers and power leads. Check resistance between terminals 1 and B (should be between 1 and 10 <math>\Omega</math>). Repeat test between terminals 2 and A. If less than 1 <math>\Omega</math> or greater than 10 <math>\Omega</math>, consult Foxboro.</p>

**Table 1. Symptoms, Probable Causes and Solutions (Continued)**

Symptoms and Probable Cause	Solution
<p><b>4. Measurement Reads Low with Flow</b></p> <p>a. Incorrect supply voltage or frequency.</p> <p>b. For ac system (with E96 Transmitter), incorrect zero adjustment.</p> <p>c. Incorrect meter factor used for E96 or 896 Transmitter.</p> <p>d. Transmitter incorrectly calibrated.</p> <p>e. Open electrode.</p> <p>f. Shorted electrode.</p> <p>g. One coil shorted in series-wired flowtube, or one coil open in parallel-wired flowtube.</p>	<p>a. Apply voltage and frequency as specified on flowtube and transmitter data plate.</p> <p>b. Adjust zero as specified in transmitter installation and operation instruction.</p> <p>c. Verify ac factor used for E96, and pulsed dc factor used for 896. Nominal factors are listed in flowtube instruction.</p> <p>d. Recalibrate transmitter per transmitter installation and operation instructions.</p> <p>e. Refer to Figure 4. Turn power off. Flowtube full with process. On flowtube, disconnect wires from signal terminal block. Using analog ohm-meter (i.e., Simpson/Triplett type), measure resistance between “white electrode wire” terminal and “black electrode wire” terminal. If resistance approaches infinity, an open or coated electrode is indicated. To check for coated electrode, see Step 1. If open electrode is indicated, return for repair.</p> <p>f. Drain flowtube. Check resistance between black electrode wire and inner screen (see Figure 4). Repeat for white electrode wire. Resistances should approach infinity. If not, remove flowtube; clean and dry liner. Recheck resistances. If still low, return for repair.</p> <p>g. Shut off ac power to flowtube (ac system) or to transmitter (pulsed dc system). Refer to Figure 4. Disconnect coil excitation wires from terminals L1 and L2; remove jumper(s) from terminals A and B. Note position of wires and jumpers for later reinstallation. Measure resistance between terminals 1 and B. Repeat test between terminals 2 and A. The difference in the measured resistance readings should be within 10% of one another. If greater than 10%, consult Foxboro. Measure resistance between each terminal to ground. Resistance should approach infinity. If not infinity, consult Foxboro.</p>

**Table 1. Symptoms, Probable Causes and Solutions (Continued)**

Symptoms and Probable Cause	Solution
<p>h. Faulty process solution earth (ground) connection.</p> <p>j. Leak in pipeline.</p> <p>k. Signal cable is too long.</p> <p>l. Coating on inside wall of flowtube and/or on electrode.</p> <p>m. For ac system (using E96 Transmitter): flowtube coil windings which should be connected in parallel have been connected in series.</p> <p>n. For ac system (using E96 Transmitter): one of the parallel-connected coil windings is open.</p> <p>p. For pulsed dc systems (using 896 Transmitter): flowtube coil windings are connected in parallel (coils should always be connected in series in pulsed dc system).</p>	<p>h. Check flange connections for rust or corrosion. Clean to ensure good electrical connection between flowtube flange and pipe flange. Refer to the applicable flowtube and transmitter instructions and check electrical connections to solution earth (ground). For list of instructions, see page 1.</p> <p>j. Check pipeline connections and valves for leaks.</p> <p>k. Check cable length vs. fluid conductivity. Refer to “Fluid Conductivity and Cabling” section.</p> <p>l. Shut off power. Drain flowtube. Disconnect signal wiring. Check resistance, using analog ohmmeter, between white electrode and inner screen. Repeat test with black electrode to inner screen. If resistance is less than infinity, flowtube and/or electrode may be coated. Remove flowtube from line and inspect for coating. If coated, clean flowtube with mild cleaning solution and soft bristle brush. <i>CAUTION: If cleaning is required, avoid damaging the flowtube lining or the electrodes.</i></p> <p>m. Check that windings are correctly connected. For arrangement of jumpers for series or parallel connection, see Figure 4.</p> <p>n. Shut off ac power to flowtube. Refer to Figure 4. Disconnect coil excitation wires from terminals L1 and L2; remove jumper(s) from Terminals A and B. Note position of jumpers and wires for later reinstallation. Check continuity between terminals L1 and B, and between terminals L2 and A. If either resistance reading is less than 1 <math>\Omega</math> or greater than 10 <math>\Omega</math>, consult Foxboro.</p> <p>p. Check that windings are in series. For arrangement of jumpers for series connection, see Figure 4.</p>

**Table 1. Symptoms, Probable Causes and Solutions (Continued)**

Symptoms and Probable Cause	Solution
<p><b>5. Measurement Reads High with Flow</b></p> <p>a. Incorrect supply voltage or frequency.</p> <p>b. Incorrect zero adjustment.</p> <p>c. Flowtube not full, or entrained air in process liquid.</p> <p>d. Transmitter incorrectly calibrated.</p> <p>e. Signal cable miswired.</p> <p>f. Faulty process solution earth (ground) connection.</p> <p>g. Coating on inside wall of flowtube and/or on electrode.</p> <p>h. For ac systems (using E96) Transmitter): flowtube coil windings which should be connected in series are connected in parallel.</p>	<p>a. Apply voltage and frequency as specified on transmitter data plate.</p> <p>b. Adjust zero as specified in transmitter installation and operation instructions. List of instructions is given on page 1.</p> <p>c. Maintain a full flowtube without entrained air in process.</p> <p>d. Check correct ac or dc factor used for E96 or 896 Transmitter. Recalibrate transmitter. For calibration details, refer to transmitter installation and operation instructions. List of instructions is given on page 1.</p> <p>e. Check that signal cable is wired per transmitter and flowtube installation and operation instructions. List of instructions is given on page 1.</p> <p>f. Check flange connections for rust or corrosion. Clean to ensure good electrical connection between flowtube flange and pipe flange. Refer to the applicable flowtube and transmitter instructions and check electrical connections to solution earth (ground). For list of instructions, see page 1.</p> <p>g. Shut off power. Drain flowtube. Disconnect signal wiring. Check resistance, using analog ohmmeter, between white electrode and inner screen. Repeat test with black electrode to inner screen. If resistance is less than infinity, flowtube and/or electrode may be coated. Remove flowtube from line and inspect for coating. If coated, clean flowtube with mild cleaning solution and soft bristle brush. <i><b>CAUTION: If cleaning is required, avoid damaging the flowtube lining or the electrodes.</b></i></p> <p>h. Check that windings are correctly connected. For arrangement of jumpers for series or parallel connection, see Figure 4.</p>

**Table 1. Symptoms, Probable Causes and Solutions (Continued)**

Symptoms and Probable Cause	Solution
<p><b>6. Erratic Flow Signal</b></p> <p>a. Defective signal or power wiring.</p> <p>b. Faulty process solution earth (ground) connection.</p> <p>c. Non-conductive substances dispersed in process.</p> <p>d. Pulsating process flow.</p> <p>e. Coating on inside wall of flowtube and/or an electrode.</p> <p>f. Transmitter is noisy.</p>	<p>a. Check signal and power wiring for defects. For wiring details, refer to transmitter and flowtube installation and operation instructions. List of instructions is given on page 1.</p> <p>b. Check flange connections for rust or corrosion. Clean to ensure good electrical connection between flowtube flange and pipe flange. Refer to the applicable flowtube and transmitter instructions and check electrical connections to solution earth (ground). For list of instructions, see page 1.</p> <p>c. Check process for presence of non-conductive substances.</p> <p>d. Check for pulsating process flow that could be affecting signal stability.</p> <p>e. Shut off power. Drain flowtube. Disconnect signal wiring. Check resistance, using analog ohmmeter, between white electrode and inner screen. Repeat test with black electrode to inner screen. If resistance is less than infinity, flowtube and/or electrode may be coated. Remove flowtube from line and inspect for coating. If coated, clean flowtube with mild cleaning solution and soft bristle brush. <b>CAUTION: If cleaning is required, avoid damaging the flowtube lining or the electrodes.</b></p> <p>f. Refer to transmitter installation and operation instructions. Apply calibration signal and check if output is stable. If not stable, consult Foxboro or refer to transmitter servicing instructions. For list of instructions, see page 1.</p>
<p><b>7. Drifting Flow Signal</b></p> <p>a. Faulty process solution earth (ground) connection.</p>	<p>a. Check flange connections for rust or corrosion. Clean to ensure good electrical connection between flowtube flange and pipe flange. Refer to the applicable flowtube and transmitter instructions and check electrical connections to solution earth (ground). For list of instructions, see page 1.</p>

**Table 1. Symptoms, Probable Causes and Solutions (Continued)**

Symptoms and Probable Cause	Solution
<p>b. Shorted electrode.</p> <p>c. Coating on inside wall of flowtube and/or on electrode.</p> <p>d. Transmitter is unstable.</p>	<p>b. Drain flowtube. Check resistance between black electrode wire and inner screen (see Figure 4). Repeat for white electrode wire. Resistances should approach infinity. If not, remove flowtube; clean and dry lining. Recheck resistances. If still low, consult Foxboro.</p> <p>c. Shut off power. Drain flowtube. Disconnect signal wiring. Check resistance, using analog ohmmeter, between white electrode and inner screen. Repeat test with black electrode to inner screen. If resistance is less than infinity, flowtube and/or electrode may be coated. Remove flowtube from line and inspect for coating. If coated, clean flowtube with mild cleaning solution and soft bristle brush <i>CAUTION: If cleaning is required, avoid damaging the flowtube lining or the electrodes.</i></p> <p>d. Refer to transmitter installation and operation instructions. Apply calibration signal and check if output is stable. If not stable, consult Foxboro or refer to transmitter servicing instructions. For list of instructions, see page 1.</p>
<p><b>8. Cannot Obtain Correct Zero Reading</b></p> <p>a. Flowtube is not full.</p> <p>b. Leak in process line (causing flow inside flowtube).</p> <p>c. Signal cable defective or miswired. Power wiring defective</p> <p>d. Faulty process solution earth (ground) connection.</p>	<p>a. Check that flowtube is full with process liquid.</p> <p>b. Check connections and valves in process line for leaks. Repair as required.</p> <p>c. Check signal and power wiring. For wiring details, refer to transmitter and flowtube installation and operation instructions. List of instructions is given on page 1.</p> <p>d. Check flange connections for rust or corrosion. Clean to ensure good electrical connection between flowtube flange and pipe flange. Refer to the applicable flowtube and transmitter instructions and check electrical connections to solution earth (ground). For list of instructions, see page 1.</p>

**Table 1. Symptoms, Probable Causes and Solutions (Continued)**

Symptoms and Probable Cause	Solution
<p>e. Leaky electrode.</p> <p>f. Coating on inside wall of flowtube and/or on electrode.</p> <p>g. Transmitter incorrectly calibrated.</p>	<p>e. Shut power off. Drain flowtube. Check that resistance between following terminals approaches infinity: white electrode and inner screen; black electrode and inner screen. If not, dry inside of flowtube and repeat resistance check. If resistance still does not approach infinity, electrode has leakage. Consult Foxboro.</p> <p>f. Shut off power. Drain flowtube. Disconnect signal wiring. Check resistance, using analog ohmmeter, between white electrode and inner screen. Repeat test with black electrode to inner screen. If resistance is less than infinity, flowtube and/or electrode may be coated. Remove flowtube from line and inspect for coating. If coated, clean flowtube with mild cleaning solution and soft bristle brush. <i>CAUTION: If cleaning is required, avoid damaging the flowtube lining or the electrodes.</i></p> <p>g. Recalibrate transmitter. For calibration details, refer to transmitter installation and operation instructions. For flowtubes with dual calibration factors (ac and pulsed dc), ensure that right factor is used with E96 and 896. List of instructions is given on page 1.</p>
<p><b>9. Measurement Reads Below Zero with Flow</b></p> <p>a. Signal wiring reversed or incorrect flow direction.</p> <p>b. Flowtube is not full.</p> <p>c. Reversed wiring to output metering device.</p>	<p>a. Refer to transmitter installation and operation instructions and connect wiring for given flow conditions. For list of instructions, see page 1.</p> <p>b. Check that flowtube is full with process liquid.</p> <p>c. Correct wiring to metering device.</p>

# 2800 Flowtube Component Locations

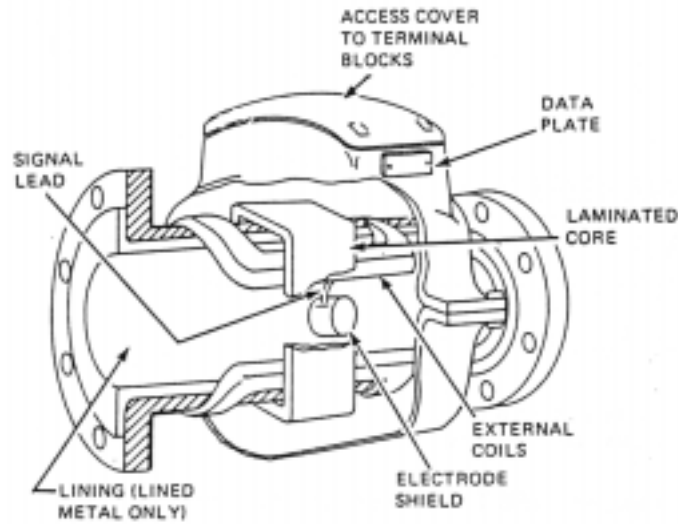

**Figure 3. 2800 Flowtube Component Locations**

## Terminal Connections

### 2800 Flowtube Terminal Connections

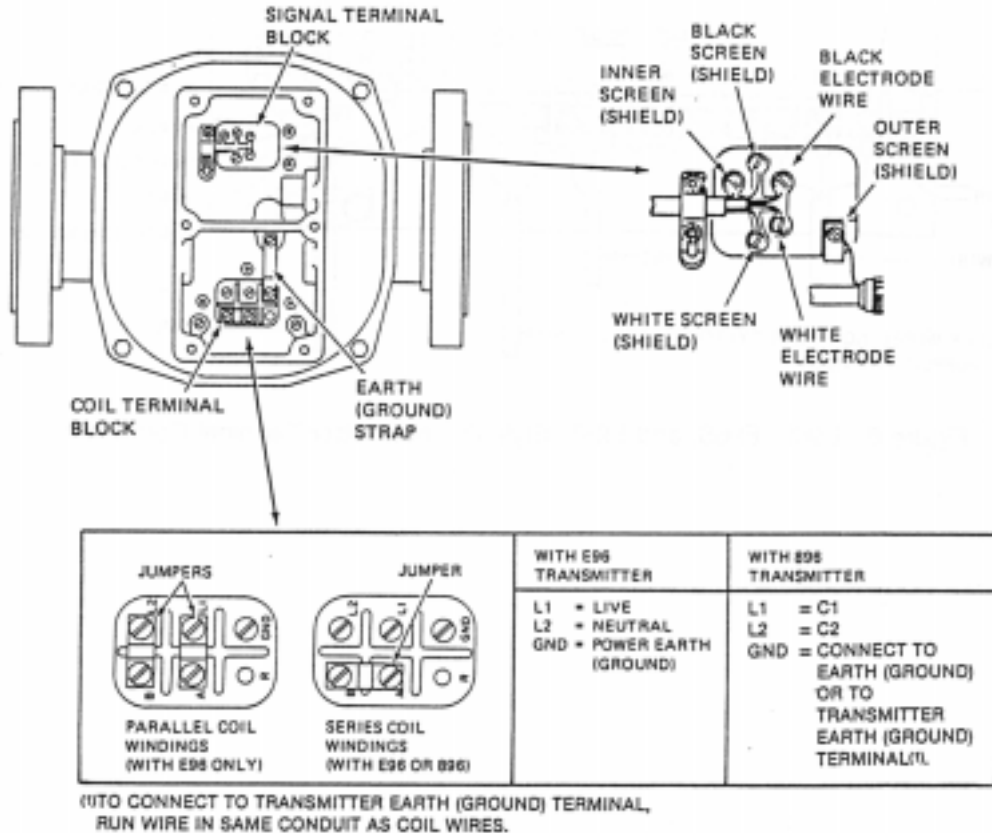

**Figure 4. 2800 Flowtube Terminal Connections**

## 896 Transmitter Terminal Connections

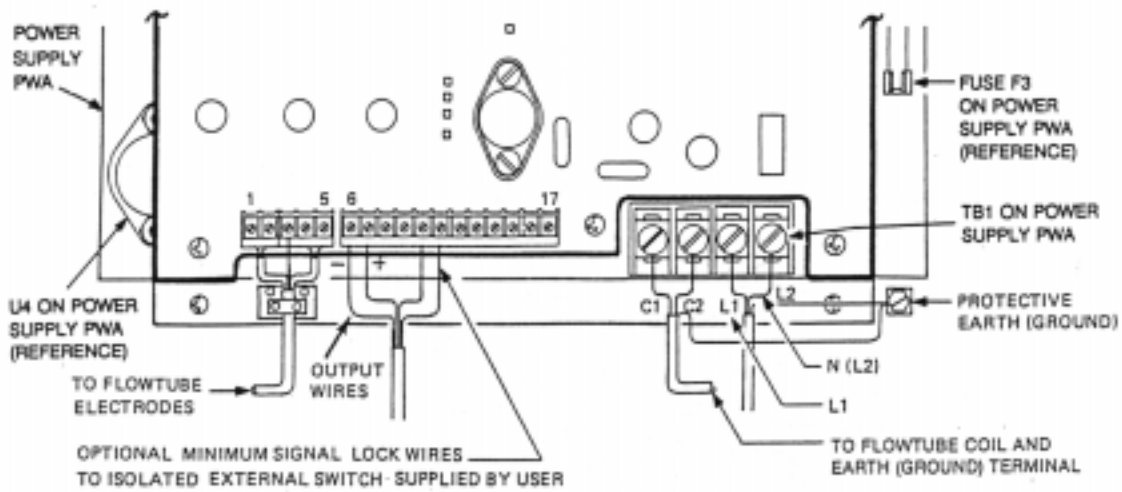

**Figure 5. 896 Transmitter Terminal Connections**

## E96P, E96S, and E96T Transmitters, Style D, Terminal Connections

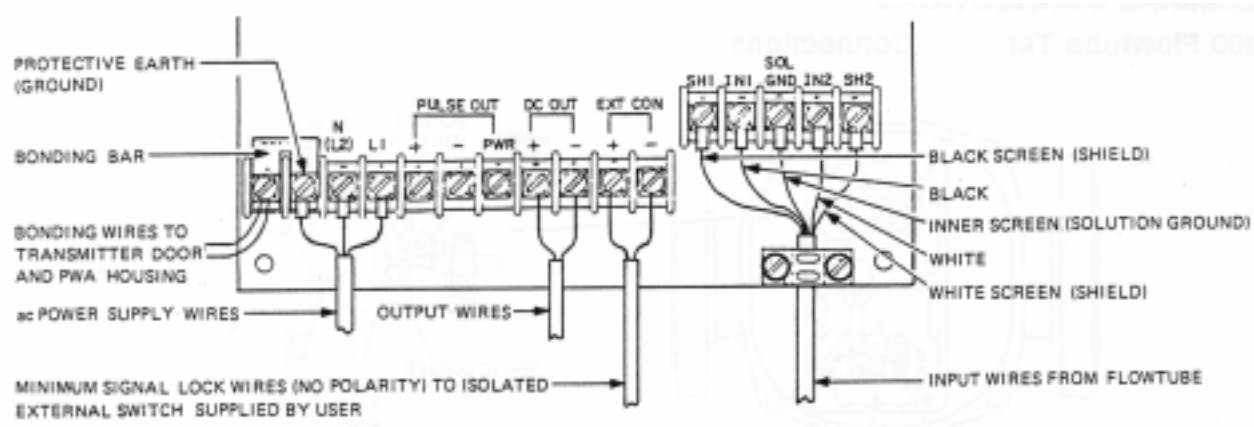

**Figure 6. E96P, E96S, and E96T, Style D, Transmitter Terminal Connections**

## E96R Transmitter, Style D, Terminal Connections

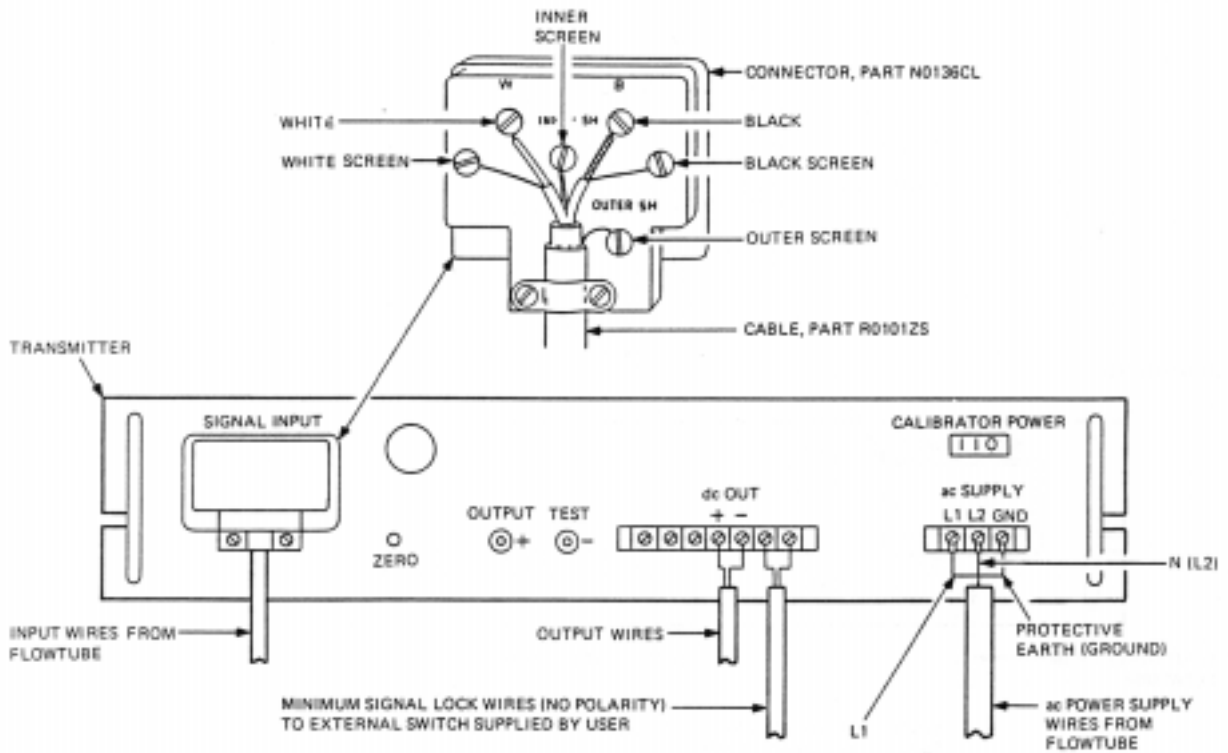

**Figure 7. E96R Transmitter, Style D, Terminal Connections**

## E96P, E96S, and E96T Transmitters, Styles A, B, and C, Terminal Connections

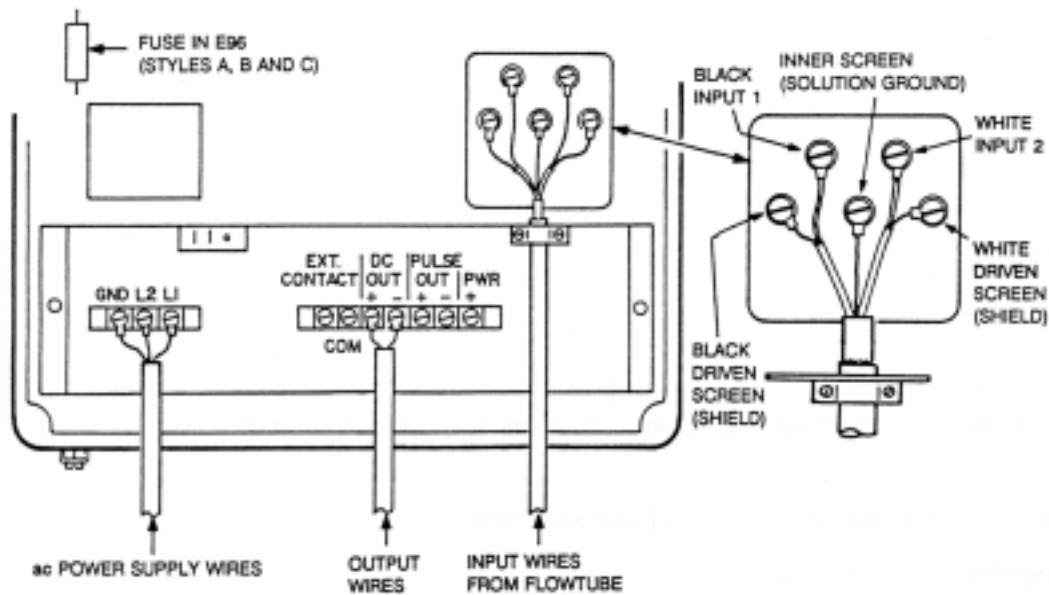

**Figure 8. E96P, E96S, and E96T Transmitters, Styles A, B, and C, Terminal Connections**

# E96R Transmitter, Styles A, B, and C, Terminal Connections

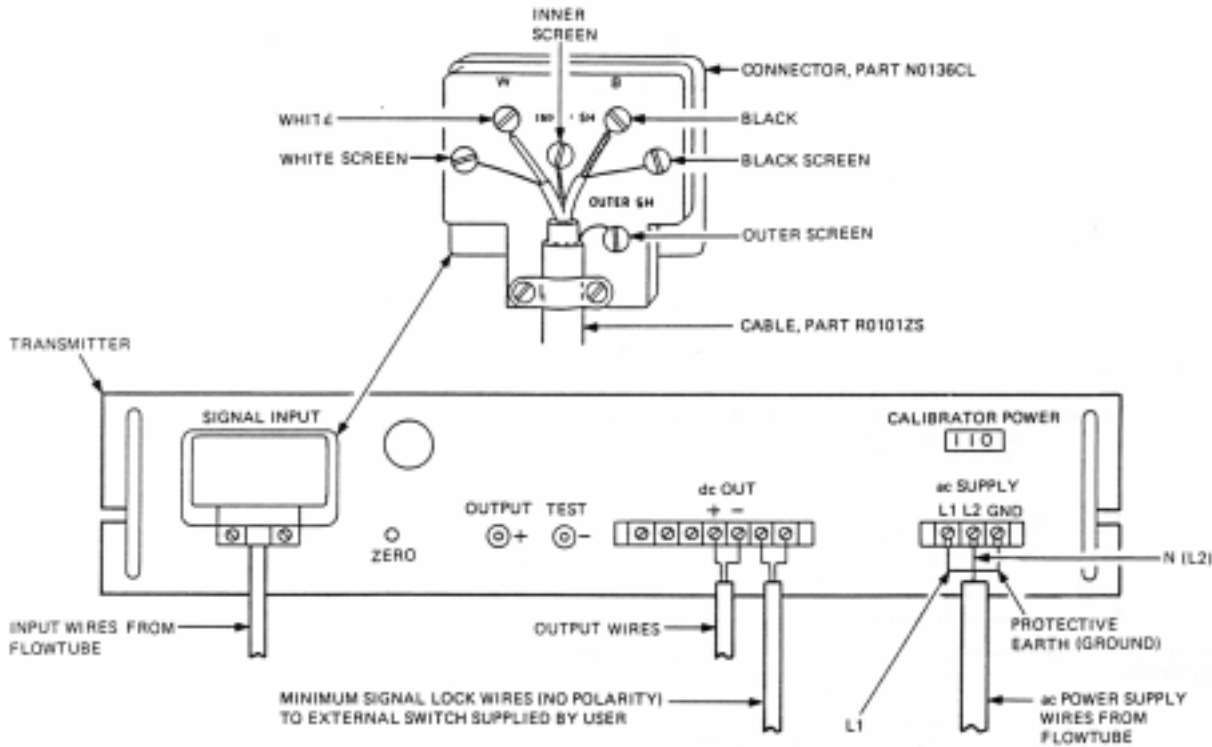

**Figure 9. E96R Transmitter, Styles A, B, and C, Terminal Connections**

**ISSUE DATES**

MAR 1993  
NOV 1995

Vertical lines to right of text or illustrations indicate areas changed at last issue date.

**The Foxboro Company**  
33 Commercial Street  
Foxboro  
Massachusetts 02035-2099  
United States of America  
<http://www.foxboro.com>  
Inside U.S.: 1-888-FOXBORO  
(1-888-369-2676)  
Outside U.S.: Contact your  
local Foxboro Representative.  
Facsimile: (508) 549-4992

Foxboro and CYCLE LOGIC are trademarks of The Foxboro Company.  
Siebe is a registered trademark of Siebe, plc.

Copyright 1993-1995 by The Foxboro Company  
All rights reserved