

**2800 Series
Sanitary Magnetic Flowtubes
ptfe Lined, 15 to 80 mm (1/2 to 3 in) Sizes**

Models	Sizes	Style
280H to 281H	15 to 40 mm (1/2 to 1-1/2 in)	B
2802 to 2803	50 to 80 mm (2 to 3 in)	C

Flowtube Installation



Contents

Figures.....	v
Tables.....	vi
1. Introduction	1
General Description	1
Reference Documents	2
Principle of Operation	2
Standard Specifications	3
Ambient Temperature (Flowtube only)	3
Electrodes	3
Metering Tube	3
Process Fluid Conductivity	3
Maximum Cable Length	3
Minimum and Maximum Upper Range Values (URV) and Nominal Calibration Factors ...	5
Enclosure Construction	6
Enclosure Finish	7
Electrical Connections	7
Mounting Position	7
End Connections	7
Approximate Mass	7
Process Temperature and Pressure Limits	8
Product Safety Specifications	8
Flowtube Identification	9
2. Installation	11
Unpacking and Handling Considerations	11
General Precautions	11
Lifting Flowtube for Mounting	12
Magnetic Flowtube Sizing	13
Installation Procedures	14
Flowtube Dimensions	14
Flowtube Location and Mounting Position	14
ptfe Lining Application	18
Mounting Procedure	18
Process Liquid and Metering Tube Continuity	20
Flowtube Field Coil Connections	20
Transmitter Installation and System Wiring	21
3. Maintenance.....	23
Index	25

Figures

1	Maximum Signal Cable Length	5
2	Process Temperature and Pressure Limits	8
3	Typical Flowtube Data Plate	10
4	Lifting Sanitary Flowtube for Horizontal Mounting	12
5	Lifting Sanitary Flowtube for Vertical Mounting	13
6	Pipeline Installation Showing a Concentric Reducer and Expander	14
7	Sanitary Flowmeter Mounted Vertically	15
8	Sanitary Flowmeter Mounted Horizontally	16
9	A Bad Installation Showing Causes of Aeration Problem (see Figure 10 for Corrected Installation) 1	7
10	A Preferred Installation to Correct the Aeration Problems Shown in Figure 9	17
11	Proper Flowtube Location to Avoid Air Entrainment due to Upstream Conditions	18
12	Mounting Sanitary End Flowtubes	19
13	Assembling Sanitary End Connection Assembly to Flowtube	20
14	Series- and Parallel-Connected Field Coils Showing Jumper Position	20

Tables

1	Reference Documents	2
2	Process Fluid Conductivity and Cabling	4
3	Flowtube Selection for Use with IMT96 Transmitters (1/2 to 3 inch) Based on Measurement Range	6
4	Flowtube Selection for Use with E96 Transmitters (1/2 to 3 inch) Based on Measurement Range	6
5	Approximate Mass	7
6	Electrical Classification	8
7	Temperature Limit for PTB Certified Flowtubes in ac (E96) Systems	9
8	Normal Recommended Flow Velocities	13
9	Lining Application Guide	18
10	Flange-Bolt Torque Values for Sanitary End Flowtubes	19

1. Introduction

General Description

The 2800 Series Sanitary Magnetic Flowtubes have been designed to operate in harsh in-plant or outdoor environments and are suitable for installation in most hazardous area locations. A selection of High Humidity/Condensate and General Purpose NEMA 4X Housings is also offered. Flowtube sizes range from 15 to 80 mm (1/2 to 3 in).

The metering tube basically consists of a stainless steel tube with a ptfe lining and stainless steel end connections. All materials are consistent with U.S. Food and Drug Administration regulations for food contact service. The assembled flowtube complies with 3-A Sanitary Standards of design for dairy equipment. The flowtube is PED qualified in EU applications for SEP (Standard Engineering Practice) Category 1 with Group 2 fluids (nonhazardous).

The ptfe-lined flowtube and crevice-free construction permit Clean-In-Place (CIP) operation. The quick-disconnect sanitary end connections provide ease of flowtube installation and removal from the line.

The flowtube is unaffected by changes in process liquid density and viscosity. It is ideally suited for many food applications. It has proven high performance with dairy products such as milk and ice cream mixes, as well as other products such as beer, soft drinks, coffee, molasses, and corn syrup. Processed products such as catsup and other viscous, sticky, or otherwise difficult-to-measure liquids are easily measured.

All flowtubes are wet calibrated to generate a calibration factor with accuracy traceable to the U.S. National Institute of Science and Technology (NIST).

The 2800 series flowtubes can be calibrated for use with different transmitter types. The Model Code of the flowtube controls which types of calibrations are provided. Refer to PL 008-541 for model code description. The transmitter types are:

- ◆ IMT96 — which uses an exponential current pulse to excite the flowtube magnetic field coils.
- ◆ E96 — where the flowtube coils are powered directly from the power line.

The calibration provides a “calibration factor” which is measurement of the voltage output from the tube generated by a flow through the tube. The factors are needed to configure (adjust) the transmitter to cover the desired flow range, such as 4 mA for zero flow and 20 mA for 100 gpm.

This instruction describes the installation of the flowtube portion of the magnetic flowmeter system. For installation, wiring, operation, configuration, and maintenance details relating to the transmitter, refer to the applicable transmitter documents.

Reference Documents

Table 1. Reference Documents

Document	Description
DP 021-141	Dimensional Print - 2800 Series Sanitary Flowtubes, 1/2 to 3 in Sizes
MI 021-333	E96P and E96S Magnetic Flow Transmitters, Installation and Operation
MI 021-334	E96R Magnetic Flow Transmitters, Installation and Operation
MI 021-335	E96T Magnetic Flow Transmitter, Installation and Operation
MI 021-402	IMT96 Magnetic Flow Transmitters - Installation
MI 021-404	IMT96 Magnetic Flow Transmitters, System Maintenance
MI 021-412	Retrofitting 2800 Flowtubes for use with IMT96 instead of E96 Transmitters.
PL 008-541	Parts List - 2800 Series Magnetic Flowtubes, 1/2 to 12 in Sizes
TI 27-71f	Magnetic Flowtube Materials Selection Guide
TI 027-072	Magnetic Flowmeter Liquid Conductivity Tables

Principle of Operation

The principle of operation of the magnetic flow meter produces a flow signal proportional to the volume flow rate through the tube. The mass flow rate can be inferred if the flowing density of the fluid is known.

The principle of operation of magnetic flow tubes is based on Faraday's law of electromagnetic induction: the voltage V_O induced in a conductor of length D_e moving through a magnetic field T is proportional to the velocity of the conductor.

$$V_O = D_e v T$$

In this application of Faraday's law, the process fluid is the conductor. The process fluid passes through the magnetic field created by the coils above and below the center section of the metering tube and a voltage is generated across the tube proportional to the average flowing velocity. The liner is necessary to make the I.D. of the tube non-conductive so that the flow signal voltage is not shorted out by the pipe wall. The flow tube has two metallic electrodes that extend through the liner and contact the fluid to detect the generated voltage.

Standard Specifications

Ambient Temperature (Flowtube only)

- ◆ Normal Operating Condition Limits: -10 and $+50^{\circ}\text{C}$ (20 and $+120^{\circ}\text{F}$)
- ◆ Operative Limits: -30 and $+60^{\circ}\text{C}$ (-20 and $+140^{\circ}\text{F}$)

— **NOTE** —

If an E96T Transmitter is integrally mounted to the flowtube, the maximum ambient temperature is 38°C (100°F).

Electrodes

AISI Type 316L Low Carbon Stainless Steel, Flat Head

Metering Tube

AISI Type 304 Stainless Steel

Process Fluid Conductivity

The minimum process fluid conductivity required is $2\ \mu\text{S}/\text{cm}$.

Maximum Cable Length

With the IMT96 Transmitter

The maximum allowable cable length between the flowtube and transmitter is a function of the cable type, process fluid conductivity, and whether the cables are in the same or separate conduits. for cable lengths greater than 150 m (500 feet) and conductivities less than $20\ \mu\text{S}/\text{cm}$, the system accuracy is affected.

Table 2. Process Fluid Conductivity and Cabling

Fluid Conductivity	Cable Length	Signal and Coil Drive Cables
>20 $\mu\text{S}/\text{cm}$	<150 m (500 ft)	Signal and coil drive cables can be in the same conduit. The signal cable can be either Foxboro cable ^(a) or good quality 14 to 18 AWG twisted shielded pair ^(b) cable. The coil wiring should be 14 AWG twisted shielded pair. ^(c,d)
	150 to 300 m (500 to 1000 ft)	Signal and coil drive cables can be in the same conduit. The signal cable can be either Foxboro cable ^(a) or good quality 14 to 18 AWG twisted shielded pair ^(b) cable. For these cable lengths, there is an additional error per every 30 m (100 ft) in excess of 150 m (500 ft): 0.2% when using Foxboro cable ^(a) . 0.4% when using 14 to 18 AWG twisted shielded pair ^(b) . The coil cable must be good quality 14 AWG twisted shielded pair ^(c) .
2 to 20 $\mu\text{S}/\text{cm}$	<150 m (500 ft)	Signal and coil drive cables should be in separate conduits. For fluid conductivity in this range, Foxboro signal cable ^(a) must be used. For these conductivities there is an additional error in percent equal to 4 divided by the conductivity in $\mu\text{S}/\text{cm}$; for example, for a conductivity of 12 $\mu\text{S}/\text{cm}$ the additional error would be 0.3%. The coil wiring should be 14 AWG twisted shielded pair. ^(c,d)
	150 to 300 m (500 to 1000 ft)	Signal and coil drive cables must be in separate conduits. For fluid conductivity in this range, Foxboro signal cable ^(a) must be used. For these conductivities there is an additional error in percent equal to 4 divided by the conductivity in $\mu\text{S}/\text{cm}$; for example, for a conductivity of 12 $\mu\text{S}/\text{cm}$ the additional error would be 0.3%. For these cable lengths, there is also an additional 0.2% error per every 30 m (100 ft) in excess of 150 m (500 ft). The coil cable must be 14 AWG twisted shielded pair ^(c) .

(a) Foxboro Part No. R0101ZS (feet) or B407TE or B4017TE (meters).

(b) Such as Belden 8760 or 9318, Alpha 5610/1801, 5611/1801.

(c) Such as Belden 8720 series or Alpha 5616 series.

(d) 14 AWG 2-core (2-conductor) cable or two separate 14 AWG wires can also be used.

16 AWG can be used for cables shorter than 90 m (300 ft).

18 AWG can be used for cables shorter than 45 m (150 ft).

With the E96 Transmitter

The maximum allowable cable length is a function of the process fluid conductivity and flowtube size. Use the graph in Figure 1 to determine the maximum length of cable.

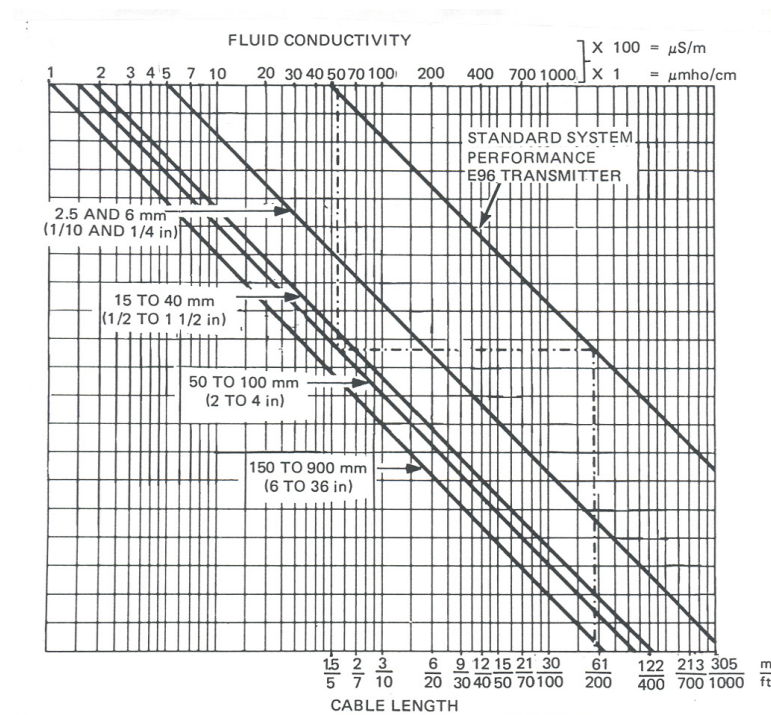

Figure 1. Maximum Signal Cable Length

— NOTE —

This graph is only valid for Foxboro cable R0101ZS connecting a 2800 Series flowtube to an E96 Transmitter. An example of how to use this graph follows:

To determine the maximum cable length for a 2802 (2 inch) flowtube when the process fluid conductivity is $55 \mu\text{S}/\text{cm}$.

1. Draw a vertical line at the fluid conductivity of $55 \mu\text{S}/\text{cm}$ to the 50 to 100 mm (2 to 4 in) flowtube reference line.
2. From this intersection, draw a horizontal line to the E96 Transmitter standard system performance line.
3. From this intersection, draw a vertical line to the cable length scale where approximately 190 feet is read as the maximum cable length.

Minimum and Maximum Upper Range Values (URV) and Nominal Calibration Factors

Minimum and maximum upper range value (URV) flow rates and nominal calibration factors are shown in Tables 3 and 4 for the different tube sizes, transmitter models, and linings.

**Table 3. Flowtube Selection for Use with IMT96 Transmitters (1/2 to 3 inch)
Based on Measurement Range**

Flowtube Size		Tri-Clamp End Connecti on Line Size	Power from IMT96	Nominal Cal Fact	Flow Measurement Range Limits			
					Minimum		Maximum ^(a,b)	
mm	in		See IMT96 MI 021-402 for wire type & gauge	Calibration Factor in $\mu\text{V/A/gpm}$	L/min 0 to:	U.S. gpm 0 to:	L/min 0 to:	U.S. gpm 0 to:
15	1/2	1	70 VA Maximum	185	4.2	1.1	75	20
25	1	1-1/2		84	15	4	290	76
40	1-1/2	2		37.6	37.5	10	740	195
50	2	3		25	60	16	1260	335
80	3	4		11.3	135	35	2900	770

(a) Maximum flow rate is based on nonabrasive fluids. Lower maximum flow rates are recommended for abrasive fluids.

(b) Maximum flow rates are based on a velocity of 10 m/s (33 ft/s).

**Table 4. Flowtube Selection for Use with E96 Transmitters (1/2 to 3 inch)
Based on Measurement Range**

Flowtube Line Size		Sanitary Tubing Size	AC Power to Flowtube							Nominal Cal Fact	Flow Measurement Range Limits			
			Available Voltage & Frequency Combinations					Watts	VA		Calibration Factor in mV/gpm	Minimum		Maximum ^(a,b)
mm	in		120 V 60 Hz	240 V 60 Hz	120 V 50 Hz	220 V 50 Hz	240 V 50 Hz						L/min 0 to:	U.S.gpm 0 to:
15	1/2	1	S(c)		S	S	S	17	275	0.450	8.4	2.2	75	20
			P(d)	S	P	P		95	1220	0.900	4.2	1.1		
25	1	1-1/2	S		S	S	S	13	195	0.125	30	8	290	76
			P	S	P	P		60	775	0.250	15	4		
40	1 1/2	2	S		S	S	S	14	175	0.050	75	20	740	195
			P	S	P	P		67	690	0.100	37.5	10		
50	2	3	S		S	S	S	13	160	0.030	120	32	1260	335
			P	S	P	P		62	625	0.060	60	16		
80	3	4	S		S	S	S	19	160	0.014	270	70	2900	770
			P	S	P	P		91	625	0.028	135	35		

(a) Maximum flow rate is based on nonabrasive fluids. Lower maximum flow rates are recommended for abrasive fluids.

(b) Maximum flow rates are based on a velocity of 10 m/s (33 ft/s).

(c) "S" means that the flowtube coils are connected in series (coil connections are field changeable).

(d) "P" means that the flowtube coils are connected in parallel.

Enclosure Construction

The housing is cast from low-copper aluminum alloy, and silicone rubber sealant is used in all joints. Several flowtube housing selections are offered.

- ◆ General Purpose (Code -G and -T): The overall construction is designed to meet the requirements of IEC IP65 and provides the watertight and corrosion resistant protection of NEMA Type 4X.

- ◆ High Humidity/Condensate (Code -C): Includes special techniques to help prevent internal condensation of condensate in applications involving cold process temperature and warm ambient.

Enclosure Finish

High-build epoxy paint

Electrical Connections

The housing has three 3/4 NPT tapped holes, two for power conduit fittings and one for a signal conduit fitting.

Mounting Position

The flowtube can be mounted in any orientation provided it remains full of process fluid. In certain applications where bubbles could form on the electrode, it is recommended that the flowtube be mounted so that the axis of the electrodes is horizontal.

End Connections

Tri-Clamp Type Coupling

Approximate Mass

Table 5. Approximate Mass

Flowtube Size		Approximate Mass	
mm	in	kg	lb
15	1/2	22.7	50
25	1	20.4	45
40	1 1/2	23.2	51
50	2	25.4	56
80	3	33.1	73

Process Temperature and Pressure Limits

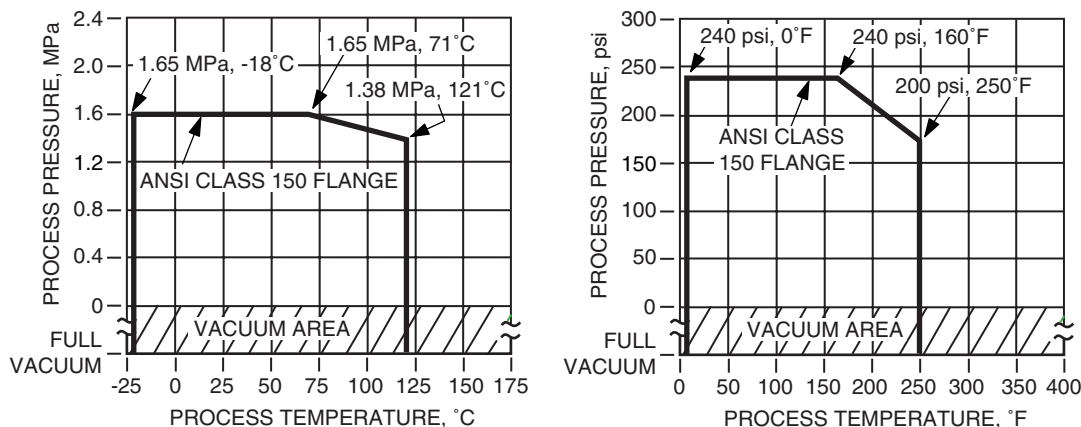

Figure 2. Process Temperature and Pressure Limits

! WARNING

Mating end connections, clamps, and gaskets selected and provided by the user may have a lower pressure limit than that shown in Figure 2. In this situation, the pressure limit of the flowtube and end connection combination are limited by the mating parts selected.

Product Safety Specifications

NOTE

The flowtube has been designed to meet the electrical safety descriptions listed in Tables 6 and 7. For detailed information or status of testing laboratory approvals or certifications, contact Invensys Process Systems.

Table 6. Electrical Classification

Testing Laboratory, Types of Protection, and Area Classification	Conditions of Certification	Electrical Safety Design Code
CSA certified for use in Class I, Groups A, B, C, and D, Division 2 hazardous locations.		CS-E/CN-A
CSA certified for Type Y Purging for Class I, Groups A, B, C, and D, Division 1.		CS-E/CP-A
FM approved for use in nonincendive Class I, Groups A, B, C, and D, Division 2 hazardous locations.		CS-E/FN-A

Table 6. Electrical Classification (Continued)

Testing Laboratory, Types of Protection, and Area Classification	Conditions of Certification	Electrical Safety Design Code
FM approved for Type Y purging intrinsically safe connection for Class I, Groups A, B, C, and D, Division 1.		CS–E/FP–A
PTB certified EEx e (ib) for IIC, Zone 1 (CENELEC).	220 V, 50 Hz coils only. Coils can be factory wired in series or parallel but cannot be changed in the field. Use only with PTB certified E96 Transmitter. Temperature Class per Table 7.	CS–E/PS–E

Table 7. Temperature Limit for PTB Certified Flowtubes in ac (E96) Systems

Flowtube Size	Coils (220 V, 50 Hz only) S = Series, P = Parallel	Process Temperature Classification			
		T3	T4	T5	T6
15 mm (1/2 in)	S	155° C	110° C	–	80° C
	P	155° C	–	–	–
25 mm (1 in)	S	155° C	110° C	–	80° C
	P	155° C	110° C	70° C	–
40 mm (1-1/2 in)	S	155° C	110° C	–	80° C
	P	155° C	–	–	–
50 mm (2 in)	S	155° C	110° C	–	80° C
	P	155° C	–	–	–
80 mm (3 in)	S	155° C	110° C	–	80° C
	P	155° C	110° C	70° C	–

Flowtube Identification

The flowtube can be identified by data plates located on the housing surface of the flowtube. A typical data plate is shown in Figure 3. For an interpretation of the Model Number, refer to Parts List PL 008-541. Refer to the applicable transmitter instruction for information regarding transmitter data plates.

2800 SERIES MAGNETIC FLOWTUBE			
MODEL			
			ST
CERT SPEC			
REF NO.			
ORIGIN			
POWER	IMT96	AC	896
SUPPLY VOLTS			
FREQ. Hz			
AMPS MAX.			
PHASE BAND			
COILS			
IMT96 CAL FACT.	IMT96		
CAL FACTOR	AC		
mV/	896		
ELECTRODES			
CUST. DATA			
<div style="text-align: center;"> invensys® FOXBORO® FOXBORO MASS U.S.A. </div>			

Figure 3. Typical Flowtube Data Plate

2. Installation

Unpacking and Handling Considerations

The 2800 Series Sanitary Magnetic Flowtube is built to be durable, but it is also part of a calibrated precision system and should be handled as such. Avoid dropping or otherwise subjecting it to impact, particularly at the flange faces.

The flowtube is shipped from the factory in a sturdy carton with foam-in-place packing material. Before removing the flowtube from the carton, move it as close as possible to its installation point. If the flowtube must be removed for receiving inspection, repack it into the carton and properly secure it with the foam-in-place material.

Lift the flowtube out of its carton with rope falls, chain hoist, etc., as shown in the “Flowtube Handling” sections that follow. The lifting technique may vary, depending on the mass of the flowtube (see approximate mass in Standard Specifications section).

—  **CAUTION** —

Never put anything through the flowtube to lift it, since this causes damage to the lining.

After removing flowtube from its shipping carton, inspect it for visible damage. If any damage is observed, notify the carrier immediately and request an inspection report. Obtain a signed copy of the report from the carrier.

Avoid touching electrodes with fingers or materials that can contaminate electrodes. Deposit on electrodes can result in a high impedance boundary between electrodes and conductive fluid. In case the electrodes have been touched, clean them with isopropyl alcohol just before installing the flowtube.

General Precautions

1. Do not cut or remove flowtube lining.
2. Check that cable length between flowtube and transmitter is within limits for specified system accuracy.
3. Good piping practice should be used for the installation of all magnetic flowtubes. Select a gasket material that is compatible with the process liquid.
4. The flowtube can be mounted in any position, vertical, horizontal, or at an angle.

— **NOTE** —

For accurate measurement, the flowtube must always be completely full.

5. The flowtube lining is susceptible to damage from excessive heat. Avoid such heat sources (such as welding adjacent piping).

! CAUTION

To avoid possible loss of accuracy with a flowtube, it is recommended that the flowtube be connected in a straight section of pipe at least five pipe diameters upstream from the center line of the flowtube and three pipe diameters downstream. The center line of the flowtube is the same location as the electrode location. Note that on some small line size flowtubes, the recommended straight runs of pipe are already included in the overall length of the flowtube.

Lifting Flowtube for Mounting

Care should be taken in lifting the flowtube into the pipeline position required for horizontal or vertical mounting. To prevent damage to the flowtube lining, housing, or the tube's structural integrity, it is important to reiterate flowtube handling precautions.

1. Never put anything through the flowtube to lift it.
2. Do not use the housing to support or lift the flowtube. Figures 4 and 5 show correct and incorrect methods for lifting the flowtubes. Note that in Figure 4 (horizontal lifting), the suggested approach is to place lifting rope (or equivalent) between the flange and flowtube body. For vertical lifting, shown in Figure 5, the lifting rope(s) should also be between the flange and the flowtube body. Adjust the rope(s) so that the flowtube is lifted as “vertically” as possible. Do NOT use the sanitary end extension section of the flowtube for either horizontal or vertical lifting.

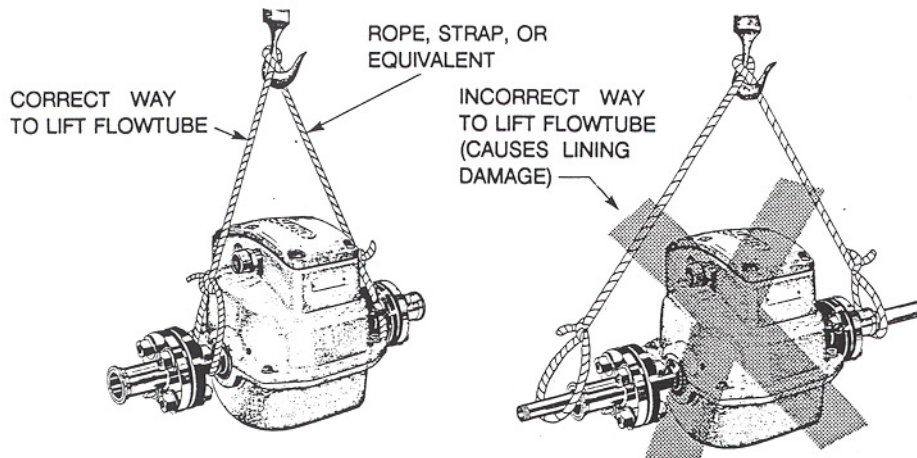

Figure 4. Lifting Sanitary Flowtube for Horizontal Mounting

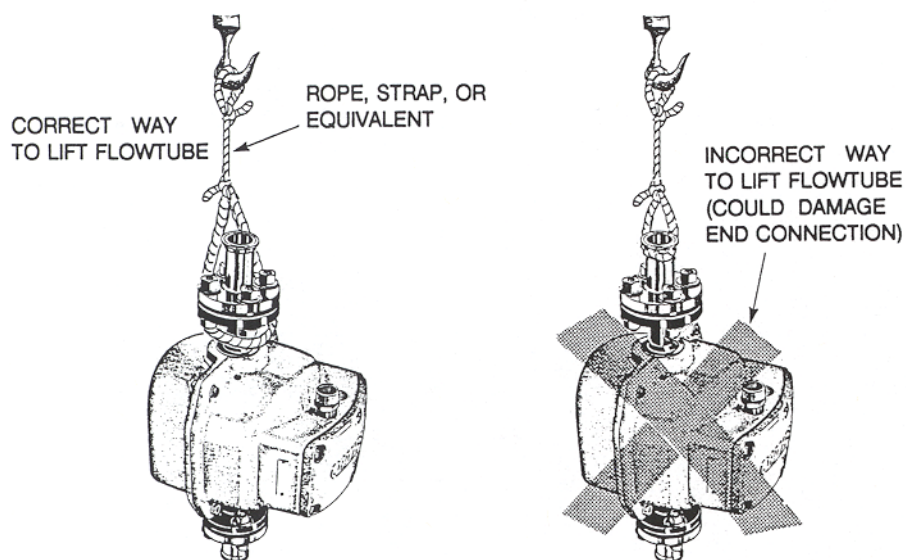

Figure 5. Lifting Sanitary Flowtube for Vertical Mounting

Magnetic Flowtube Sizing

The flowtube operates over a flow velocity range of 0 to 33 ft/s (0 to 10 m/s). Proper flowtube sizing is essential to ensure premium performance and longevity. Refer to Table 8 as a guide to sizing of magnetic flowtubes.

Table 8. Normal Recommended Flow Velocities

Process Liquid	Velocities Corresponding to Normal Flow Should be Between
General Liquids	3 ft/s and 15 ft/s 0.91 m/s and 4.6 m/s
Erosive Slurries	3 ft/s and 6 ft/s 0.91 m/s and 1.8 m/s
Liquids that can Coat the Inside Surface of Flowtube	6 ft/s and 15 ft/s 1.8 m/s and 4.6 m/s

If the flow velocity in the pipeline is low, reducers can be used to install a smaller flowtube. Concentric reducers with a taper angle of eight degrees (8°) or less per side are preferred (eccentric reducers with a maximum taper angle of 8° can also be used), and can be connected directly to the flowtube. Refer to Figure 6 for a typical reducer installation. The unrecovered pressure loss caused by using reducers to increase the velocity in the tube to 5 to 10 ft/s (1.5 to 3 m/s) is small, typically less than 1 psi (<27.7 inH₂O, <51.7 mmHg). Equations to calculate the pressure loss can be found in “Fluid Flow through Valves, Fittings, and Pipes,” Technical Paper 410, by the Crane Co.

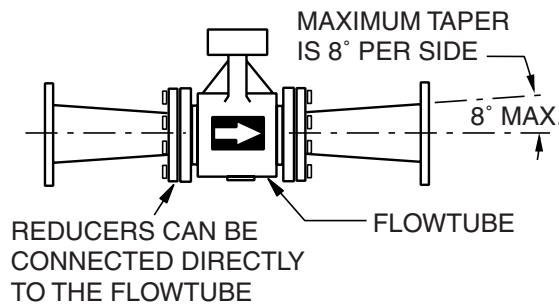

Figure 6. Pipeline Installation Showing a Concentric Reducer and Expander

If normal flow is above the recommended maximum flow velocity, the flowtube liner wear rates become a concern. Generally, expanding a section of the pipeline to install a larger tube is **not** a good solution, as it creates potential air problems. If you have a high process velocity, consider the following recommendations:

- ◆ Install the flowtube where there is a long, straight, upstream piping run
- ◆ Install a liner protection ring at the upstream end of the flowtube.

Operating the flowmeter outside the recommended normal flow velocity limits can result in performance degradation, maintenance problems, and/or shortened life expectancy. Invensys Process Systems therefore provides its FlowExpertPro™ Sizing Software to facilitate and simplify the flowmeter sizing procedure for any application.

Installation Procedures

Flowtube Dimensions

Refer to DP 021-141.

Flowtube Location and Mounting Position

Installation and Orientation Guidelines

- ◆ The magnetic flowtube must be installed so that it remains full of liquid during operation. An example of good orientation of the flowtube is in a vertical pipeline with flow in an upward direction, as shown in Figure 7.
- ◆ The flowtube should have straight, unobstructed piping for a distance of five pipe diameters (5 PDs) upstream and 3 PDs downstream (measured from the center of the flowtube) to ensure optimum performance (see Figure 7). Adjacent process piping should have the same diameter or be slightly larger than the flowtube.
- ◆ When installed in a horizontal pipe, the flowtube should be oriented so that the electrodes are not located near the top or bottom of the pipe (see Figure 8). Adjacent piping can be elevated so as to maintain a full flowtube.

- ◆ Tube orientation should not trap entrained air, nor cause a build-up of undissolved solids within the flowtube.
- ◆ Check valves can be installed to ensure a full flowtube and prevent drainage under static flow conditions.
- ◆ Flowmeter performance can be affected if liquids are blended together upstream and are too near the flowtube. There must be enough piping upstream of the meter, between the blending point and the flowtube, to allow for a complete mixing of the liquid streams. This is one of the few cases where you may need to install more than 5 PDs of straight pipe upstream of the flowtube. An in-line static mixer can be installed upstream of the flowtube to insure proper mixing in very tight piping situations.
- ◆ Figure 7 also shows a flow direction arrow. However, the tube can be installed in the reverse direction if this orientation provides better wiring access to the connection box (tube performance is the same in both directions). If you do install the tube in the reverse direction, then configure the transmitter flow direction parameter for reverse flow, or reverse the polarity of the electrode wires.

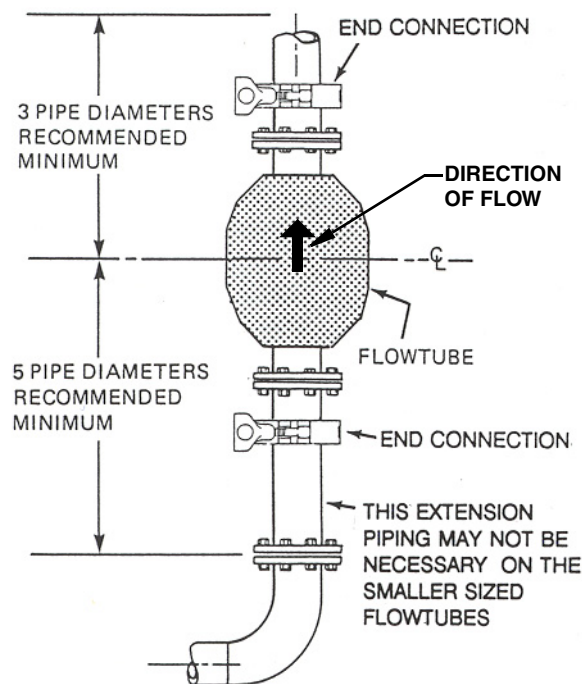

Figure 7. Sanitary Flowmeter Mounted Vertically

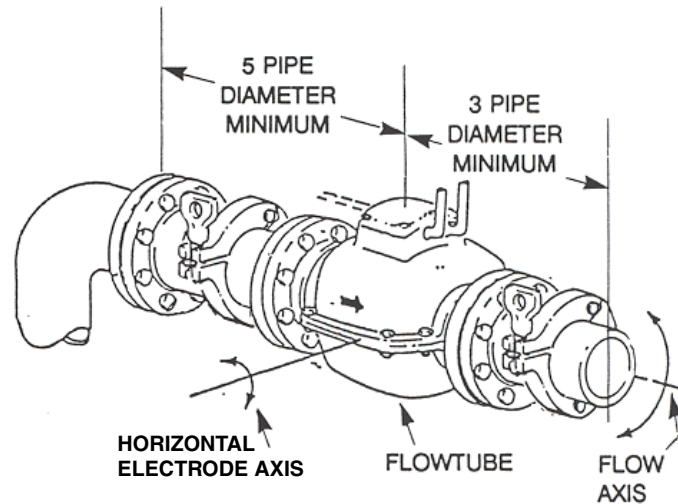

Figure 8. Sanitary Flowmeter Mounted Horizontally

Probably the most common reason for magnetic flow errors and erratic performance is air in the flow stream. A magnetic flowmeter is a volume flow instrument, and, as such, shows the total volume flow rate of liquid and gas passing through the tube. Therefore, if the fluid is 1% by volume of air, the flow signal is 1% greater than the amount of liquid flowing. If the entrained air is well mixed, the flow signal will be stable, but high. If the air builds up in the piping until it becomes a sizable bubble and then passes through the pipeline, there will then be disturbances of the flow rate through the tube and the output of the tube will appear to be unstable.

To avoid problems with air in the flow stream:

- ◆ Avoid installing the tube in a location that may not be full in all operating conditions.
- ◆ Avoid (or correct) upstream conditions that may draw air into the flow stream.
- ◆ Avoid (or correct) upstream conditions where any air that is entrained in the flow could collect into a large bubble, and then flow downstream. High spots and places where the flow velocity slows are likely places to create this problem.

Figures 9 to 11 show causes of aeration problems, and preferred installations that can correct these problems.

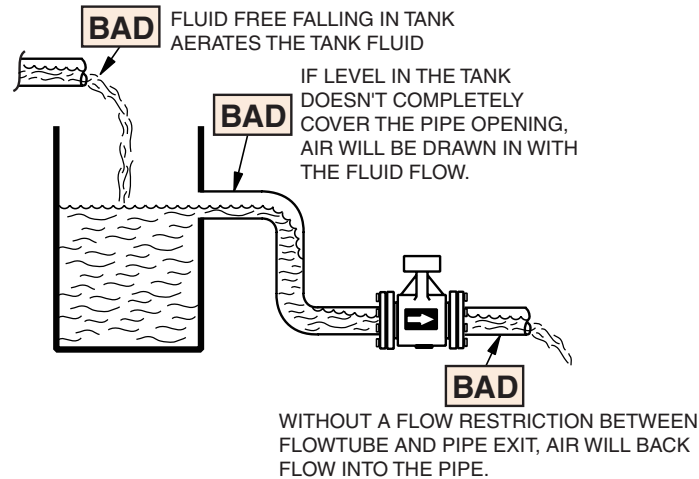

*Figure 9. A Bad Installation Showing Causes of Aeration Problem
(see Figure 10 for Corrected Installation)*

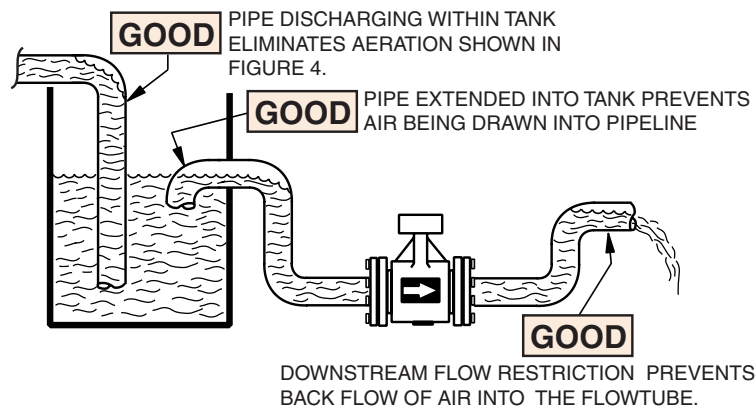

Figure 10. A Preferred Installation to Correct the Aeration Problems Shown in Figure 9

NOTE

See Figure 11 for proper flowtube location to avoid air entrapment due to upstream conditions.

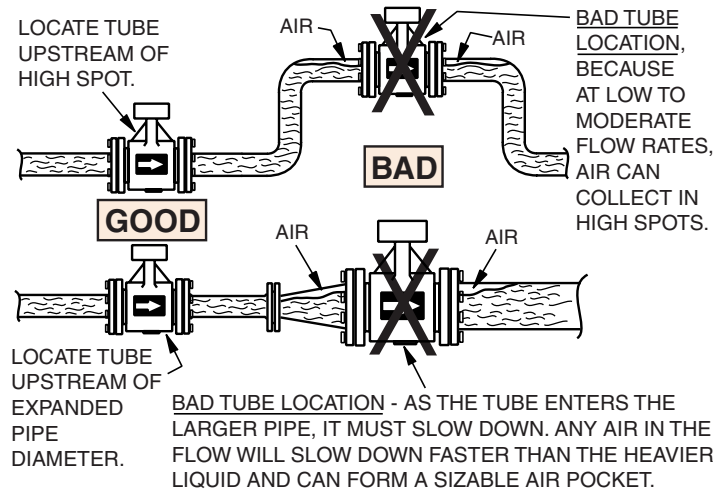

Figure 11. Proper Flowtube Location to Avoid Air Entrainment due to Upstream Conditions

ptfe Lining Application

Refer to Table 9 for recommended application of ptfе linings. Also refer to TI 27-71f to best determine compatibility of the ptfе lining with fluid types and fluid characteristics.

Table 9. Lining Application Guide

Flowtube Construction	Fluid Characteristic ^(a,b)					
	Clean	Mild Corrosion	Severe Corrosion	Mild Abrasion	Severe Abrasion	Mild Corrosion and Abrasion
ptfe Lining	A	A	A	B	X	B

(a) A = Preferred: Generally considered best choices.

B = Satisfactory: Reasonable life under most conditions.

X = Not Recommended: Generally considered unsuitable.

(b) This flowtube is PED qualified in EU applications for SEP (Standard Engineering Practice) Category 1 with Group 2 fluids (nonhazardous).

Mounting Procedure

Sanitary end flowtubes have the Tri-Clamp type coupling end connections already assembled to the magnetic flowtube. This is necessary to comply with 3A Sanitary Standards.

Prior to mounting the sanitary end flowtubes, if the abutting piping is in place, spring back this piping on either side to allow as much space as is required to install the flowtube without damaging the flowtube ends. Full face contact should be made prior to installing the connection clamps or clamping nuts. Refer to DP 021-141 for end-to-end dimensions, and to Figure 12 for mounting information.

The flowtube generally requires no more support than an equal length of pipe. However, care should be taken not to overstress the end connection interfaces. When the flowtube is vertically mounted, it should not be used to support the piping above it. Do **not** use the flowtube housing surface to support the installation. Refer to Figure 12.

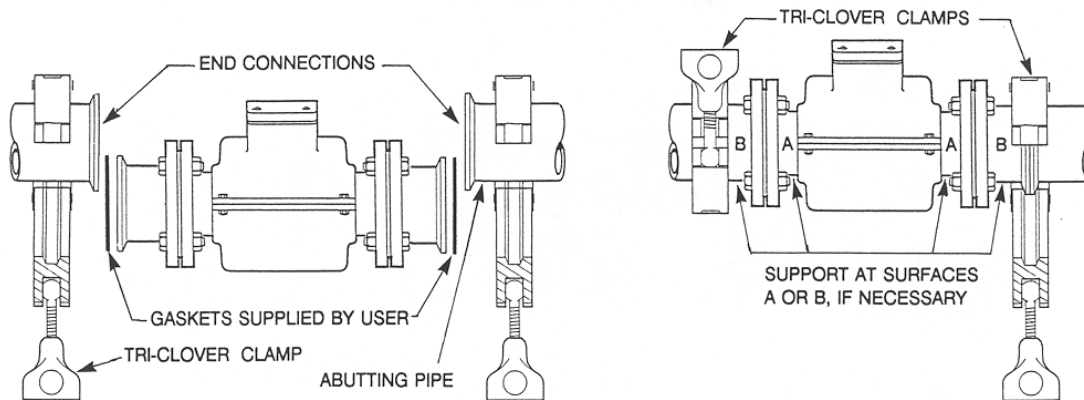

Figure 12. Mounting Sanitary End Flowtubes

Should it become necessary to remove or replace the sanitary end connection extension assembly, remove the flange bolts and remove the extension assembly. Reassemble the extension assembly as shown in Figure 13, and in accordance with the flange-bolt torque values listed in Table 10.

Table 10. Flange-Bolt Torque Values for Sanitary End Flowtubes

Flowtube Size		Sanitary Line Size	Number of Bolts in Flange	Flange-Bolt Torque	
mm	in	in		N ⋅ m	lb ⋅ ft
15	1/2	1	4	6	4
25	1	1-1/2	4	10	7
40	1 1/2	2	4	20	15
			8	14	10
50	2	3	4	27	20
			8	20	15
80	3	4	4	54	40
			8	34	25

— NOTE —

Bolts should be tightened gradually and in a sequence consistent with good flange-bolt tightening procedures. Do **not** overtighten, as this can damage the ptfе lining.

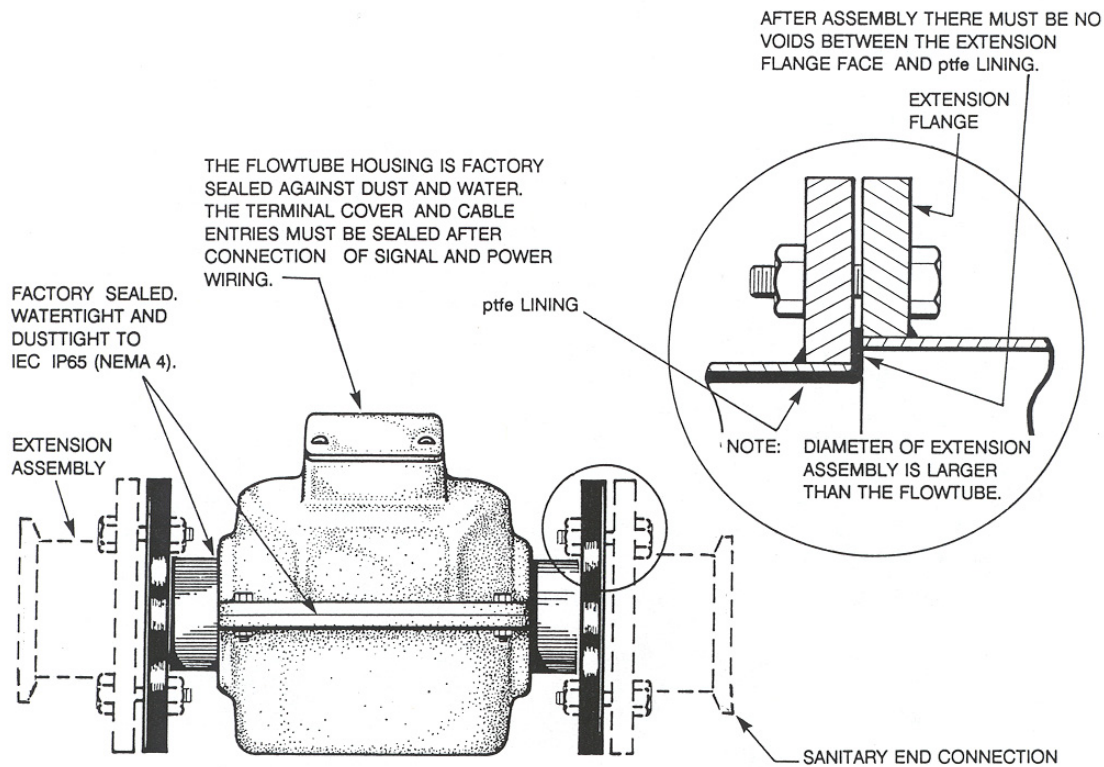

Figure 13. Assembling Sanitary End Connection Assembly to Flowtube

Process Liquid and Metering Tube Continuity

Your sanitary flowtube does not require pipeline ground wires to establish the process fluid reference signal. The sanitary end connections of your flowtube provides the contact. For electrical safety it is necessary to make a power ground connection as shown in the flowtube to transmitter wiring section of the transmitter instruction.

Flowtube Field Coil Connections

The flowtube coils can be connected either in series or in parallel as shown in Figure 14.

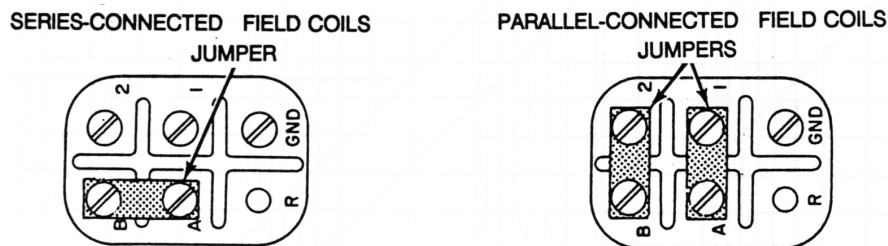

Figure 14. Series- and Parallel-Connected Field Coils Showing Jumper Position

1. With an IMT96 Transmitter, use series coils (except for 1/2- through 8-in flowtubes dual calibrated for 220/240 V 50 Hz E96).
2. With an E96 Transmitter, both series and parallel connections are used. Check the data plate.

— **NOTE** —
120 V parallel and 220/240 V series configurations are interchangeable.

Transmitter Installation and System Wiring

Transmitter installation and system wiring (flowtube and transmitter) are described in the applicable transmitter installation instructions. Refer to Table 1 for the applicable transmitter document.

3. Maintenance

If a fault is suspected in the flowtube, first make exterior checks for wire continuity and rusted or corroded flanges and/or flange bolts. Rusted flanges and/or bolts can result in a poor process earth (ground). Use ultrasonic cleaner or low-voltage cleaning procedure, if the flowtube is so equipped, to clean electrodes.

If it becomes necessary to clean flowtube, avoid damaging the tube interior. Do **not** exceed temperature or pressure limits of flowtube.

System fault location and maintenance information are described in MI 021-402 (if using an IMT96 Transmitter) or MI 021-138 (if using an E96 Transmitter). For flowtube parts, refer to PL 008-541.

Index

C

- Cable Length 3
- Calibration Factor, Nominal 5
- Coil Connections 20
- Conductivity, Process Fluid 3
- Continuity Between Process Liquid and Metering Tube 20

E

- Electrical Connections 7
- Electrodes 3
- Enclosure Construction 6
- Enclosure Finish 7
- End Connections 7

F

- Flowtube
 - Coil Connections 20
 - Lifting for Mounting 12
 - Lining 18
 - Sizing 13

I

- Identification 9
- Installation 11, 14

M

- Maintenance 23
- Metering Tube 3
- Mounting Position 7, 14
- Mounting Procedure 18

P

- Precautions, General 11
- Pressure and Temperature Limits, Process 8
- Principle of Operation 2
- Process Fluid Conductivity 3

R

- Reference Documents 2
- Reference Signal, Process Liquid 20

S

- Specifications
 - Product Safety 8
 - Standard 3

T

- Temperature and Pressure Limits, Process 8
- Temperature, Ambient 3
- Transmitter Installation 21

U

- Unpacking and Handling Considerations 11
- Upper Range Values, Minimum and Maximum 5

W

- Wiring, System 21

ISSUE DATES

- MAR 1985
- SEP 1986
- APR 1993
- JAN 2000
- APR 2005
- SEP 2008
- MAR 2009

Vertical lines to the right of text or illustrations indicate areas changed at last issue date.



IPS Corporate Headquarters
 5601 Granite Parkway Suite 1000
 Plano, TX 75024
www.ips.invensys.com

Foxboro Global Client Support
 Inside U.S.: 1-866-746-6477
 Outside U.S.: 1-508-549-2424 or
 contact your local Foxboro
 representative.
 Facsimile: 1-508-549-4999

Invensys, Foxboro, and I/A Series are trademarks of Invensys plc, its subsidiaries, and affiliates. All other brand names may be trademarks of their respective owners.

Copyright 1985-2009 Invensys Systems, Inc.
 All rights reserved